

PROPRIETARY DATA

HE1000-C

F

PROPERTY OF ACE ROTO-MOLD MFG., INC. INFORMATION FURNISHED HEREIN IS THE PROPERTY OF ACE ROTO-MOLD MFG., INC. AND SHALL NOT BE USED, DISCLOSED TO OTHERS, OR COPIED WITHOUT THE EXPRESSED WRITTEN CONSENT OF ACE ROTO-MOLD MFG., INC. ALL RIGHTS RESERVED.

KEY	PART NUMBER	MATERIAL	DESCRIPTION	QTY.
1	HE1000-C-1	S-12GA	SHEET, 12 GA	71.5" X 88.5"(6327.75 SI)
2	HE1000-C-2	S-12GA	SHEET, 12 GA	2.5 X 88.5"(221.25 SI)
3	HE1000-C-3	B02500X20000	FLAT, 1/4 X 2	2 @ 31.375"(62.75 IN)
4	HE1000-C-4	B02500X40000	FLAT, 1/4 X 4	6 @ 24"(144 IN)
5	HE1000-C-5	A01875X20000	ANGLE, 3/16 X 2	2 @ 74"(148 IN)
6	HE1000-C-6	A02500X40000	ANGLE, 1/4 X 4	4 @ 66.25"(265 IN)
7	SJ17011	S-10GA	SHEET, 10 GA	2 @ 21.125" X 74"(3126.5")

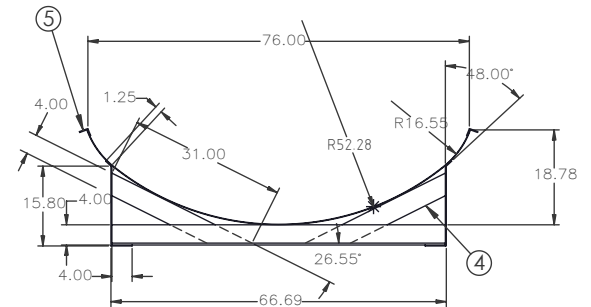
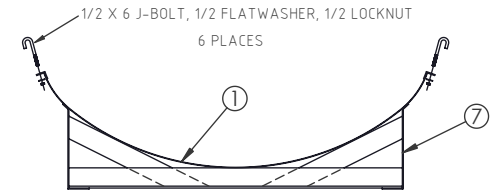
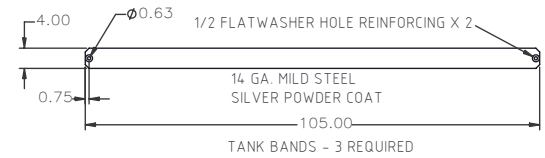
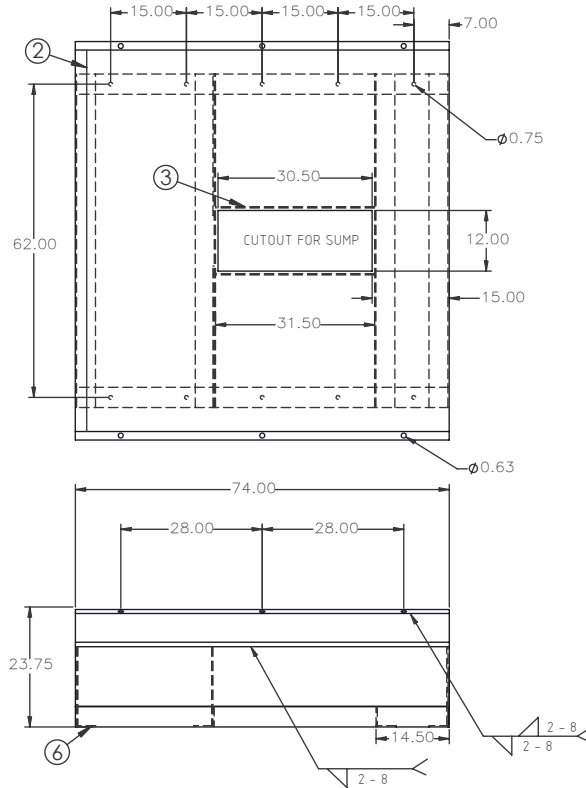

F	TOLERANCE WAS .5% @ 68°F	GWC 3/8/07	
E	CHANGE BAND TO MILD	8/9/06	
D	VERIFY DIMENSIONS	1/5/06	
C	ENLARGE SUMP CUTOUT 1X1	9/15/05	
B	LENGTHEN BY 2 IN	5/25/05	
A	ENLARGE SUMP CUTOUT	5/23/05	
REV	DESCRIPTION	BY / DATE	CCN

DRAWN / DATE	MATERIAL
ADH 7/24/07	
APPRD. / DATE	
REH 10/5/07	



Den Hartog
INDUSTRIES, INC.

Ace Roto-Mold Injection Molding Blow Molding Sowjoy

4010 HOSPERS DRIVE S. BOX 425, HOSPERS, IOWA 51238-0421

ALL DIMENSIONS ARE IN DECIMAL INCHES
TOLERANCES UNLESS OTHERWISE SPECIFIED

DECIMAL ± .125"
FRACTION ± 1/4"
ANGLE ± 1°

THIRD ANGLE PROJECTION
ANSI 14.5M

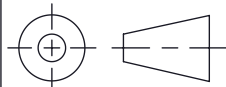

NOTES:

DESCRIPTION ACE 1000 GALLON ELLIPTICAL CRADLE

SCALE N.S.

PART NO. HE1000-C