

PROPRIETARY DATA

PROPERTY OF DEN HARTOG MFG, INC. INFORMATION FURNISHED HEREIN IS THE PROPERTY OF ACE ROTO-MOLD MFG, INC AND SHALL NOT BE USED, DISCLOSED TO OTHERS, OR COPIED WITHOUT THE EXPRESSED WRITTEN CONSENT OF ACE ROTO-MOLD MFG, INC. ALL RIGHTS RESERVED.

KEY	PART NUMBER	MATERIAL	DESCRIPTION	QTY.
1	SJHZ0025C-1	A01250X15000	ANGLE, 1/8 X 1 1/2"	2 @ 19.5 IN(39 IN)
2	SJHZ25-55C-8	S-1875	SHEET 3/16"	2 @ 216 SI(432 SI)
3	HZ0025-CSBS	HZ0025-CSBS	HZ,SS BAND 25 GAL SINGLE	2
4	BB5/16X3BAG-4	BB5/16X3BAG-4	BOLT BAG, 5/16" X 3" J-BOLT	1

HZ0025-C

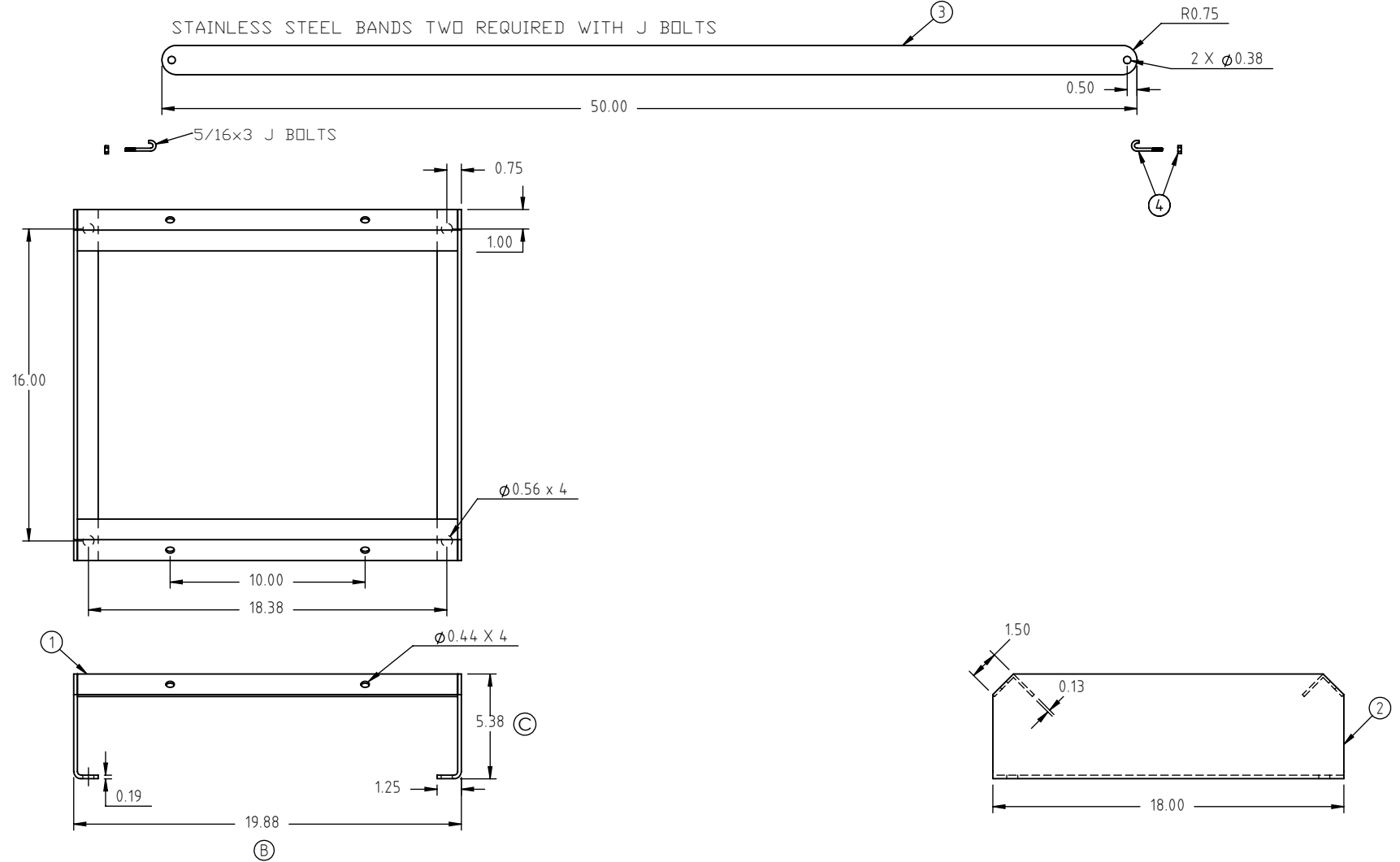

REV	DESCRIPTION	BY / DATE	CCN	THIRD ANGLE PROJECTION ANSI 14.5M	NOTES:
C	5.38 WAS 5.00, BOLT BAG AND BANDS ADDED TO TABLE	ADH 5/13/09	1862		
B	DRAWING DIMENSION 19.88 WAS 19.75	ADH 2/4/08	1584		
A	TOLERANCE WAS 1% @ 68°F	GWC 3/14/07			

ALL DIMENSIONS ARE IN DECIMAL INCHES
TOLERANCES UNLESS OTHERWISE SPECIFIED
DECIMAL ± .125"
FRACTION ± 1/4"
ANGLE ± 1°



Den Hartog

INDUSTRIES, INC.

Ace Roto-Mold Injection Molding Blow Molding Sowjoy

4010 HOSPERS DRIVE S. BOX 425, HOSPERS, IOWA 51238-0421

DESCRIPTION	CRADLE FOR 25 GALLON HORIZONTAL	
SCALE	N.S.	PART NO. HZ0025-C