

PROPRIETARY DATA

PROPERTY OF ACE ROTO-MOLD MFG., INC. INFORMATION FURNISHED HEREIN IS THE PROPERTY OF ACE ROTO-MOLD MFG., INC. AND SHALL NOT BE USED, DISCLOSED TO OTHERS, OR COPIED WITHOUT THE EXPRESSED WRITTEN CONSENT OF ACE ROTO-MOLD MFG., INC. ALL RIGHTS RESERVED.

KEY	PART NUMBER	MATERIAL	DESCRIPTION	QTY.
1	IN30/60-ST-1	P05000	TUBING, 1/2" PIPE SIZE	3 @ 33 IN (99 IN) (HOLE INCLUDED)
2	IN30/60-ST-2	P05000	TUBING, 1/2" PIPE SIZE	1
3	IN30/60-ST-3	B01875X10000	3/16" X 1" MILD STEEL	74.75 IN
4	12582	62202	1/2" PIPE PLUG	3
5	IN30/60-ST-5	R0375	3/8 MILD STEEL ROD	3 @ 20.875 IN (62.625)
6	12081	B01875X1500	FLAT, 3/16 X 1 1/2 MILD STEEL	3 @ 22.44 IN (67.31 IN)
7	J.313X3.00	J.313X3.00	J BOLT, 5/16" X 3"	1
8	10280	10280	NUT, 5/16" NYLOK	1

IN30/60-ST

G

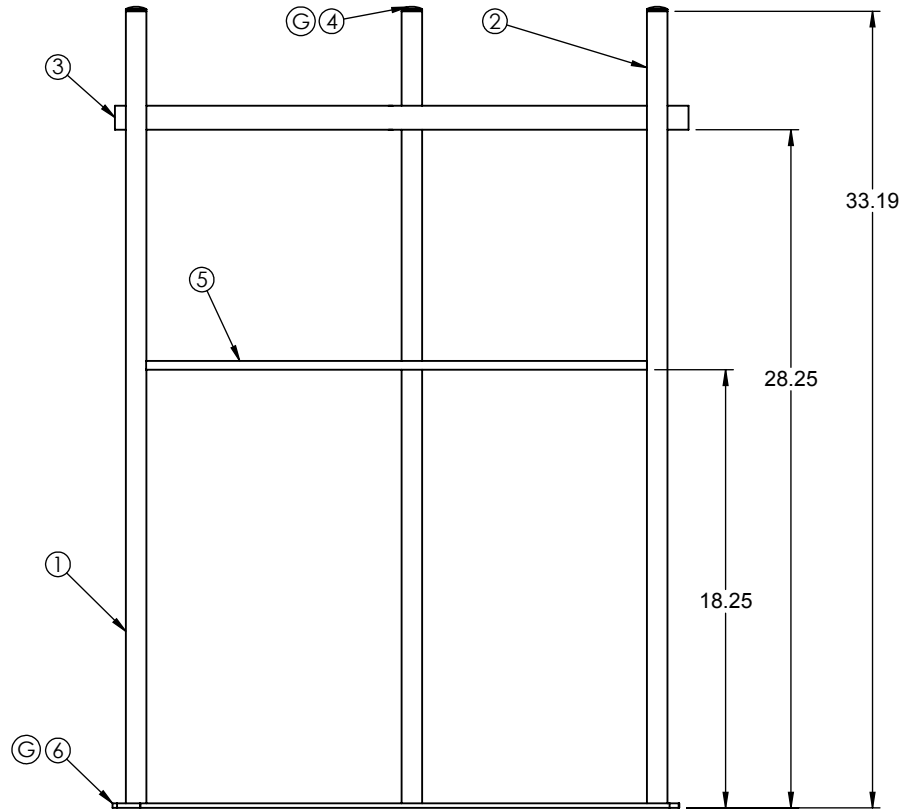
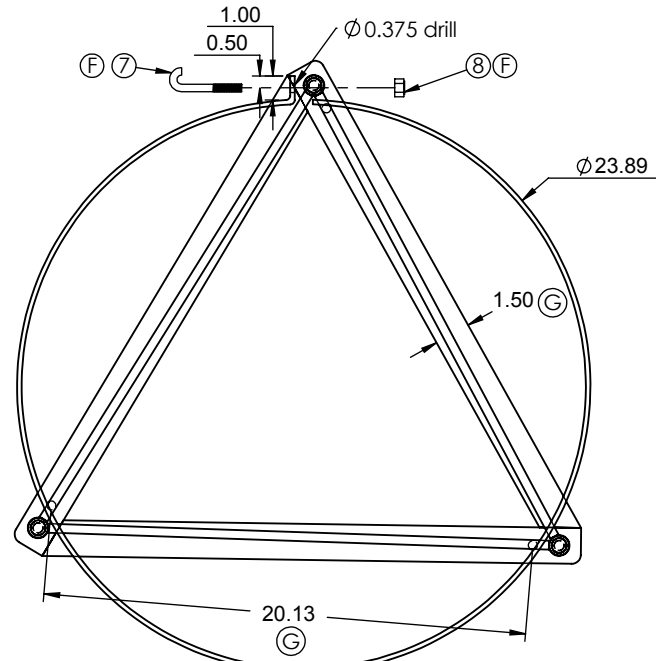

G	DIMENSIONS, BASE STRAPS AND LEG PLUGS UPDATED	ADH 10/10/08	1729
F	PARTS 7,8 AND FINISH NOTE ADDED WEIGHT UPDATED	ADH 3/21/08	1626
E	CORRECTED PART NUMBER	ADH 10/31/07	1506
D	TOLERANCE WAS 1% @ 68°F	GWC 3/15/07	
C	ADD TANK CLEARANCE	2/5/07	
B	CHANGE BASE THICKNESS		
A	GENERAL PRINT UPDATE		
REV	DESCRIPTION	BY/DATE	CCN

DRAWN / DATE	MATERIAL
ADH 7/17/07	
APPRD. / DATE	
REH 10/5/07	



Den Hartog
INDUSTRIES, INC.

Ace Roto-Mold Injection Molding Blow Molding Sowjoy
4010 HOSPERS DRIVE S. BOX 425, HOSPERS, IOWA 51238-0421

ALL DIMENSIONS ARE IN DECIMAL INCHES
TOLERANCES UNLESS OTHERWISE SPECIFIED

DECIMAL ± .125"
FRACTION ± 1/4"
ANGLE ± 1°

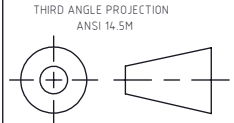

NOTES:
1.) POWDER COATING, BLACK TILE, 40012
2.) WEIGHT: 17.5 LBS

DESCRIPTION	INDUCTOR STAND FOR 30/60 GALLON TANKS	
SCALE	N.S.	PART NO. IN30/60-ST