



Ace Roto-Mold

A DIVISION OF DEN HARTOG INDUSTRIES, INC.

APPLICATION GUIDELINES



Den Hartog
INDUSTRIES, INC.

UPDATED APRIL 2011

Ace Roto-Mold • Injection Molding • Blow Molding • Sowjoy

4010 Hospers Drive South

P.O. Box 425

Hospers, IA 51238-0425

712-752-8432 800-342-3408

fax 712-752-8222

www.denhartogindustries.com

APPLICATION GUIDELINES

TABLE OF CONTENTS

	PAGE
A. Tank Selection and Application Guidelines	1
B. Chemical Resistance Data Chart	2-4
C. Materials Information	5
D. Tank Drawings	6-10
E. Handling, Installation and Use Guidelines	11-13
F. Fitting Installation Guidelines	14
G. General Information	15-16
Pricing and Terms	
Product Performance	
Shipping and Transportation	
Returned Goods Policies and Warranties	
H. Limited Warranty and Disclaimer	17-19
I. Conversion Charts and Formulas	20-21
Specific Gravity Conversion Chart	22
I. Item Number Matrix	23

Ace Roto-Mold Tanks – a tradition of quality

Ace Roto-Mold tanks have been available to the market since 1990. The company's vision was to provide unparalleled quality and service. Today, this reputation remains the cornerstone of our wide range of products as we strive to meet the requirements of the agricultural and industrial users. This commitment to quality and service is met with continual investment in the latest manufacturing technologies and in trained, capable employees.



Tank Selection and Application Guidelines

How to select the proper tank for your application

- STEP 1** Identify the chemical(s) to be stored in the tanks. Be certain to obtain a Certificate of Composition, MSDS (Material Safety Data Sheet) or other data from the chemical supplier so that the actual chemical compounds can be identified to properly evaluate the effect of the chemical on polyethylene storage containers. See page 5 for additional material information.
- STEP 2** Review the Chemical Resistance Data Chart (pages 2-4). This will determine if the chemical to be stored is compatible with polyethylene. Be certain to consider the temperature limitations for your application. If this resistance data does not list the chemical you intend to store in the tank, contact the chemical manufacturer for recommendations regarding storage in polyethylene tanks.
- STEP 3** Select the necessary tank size and accessories according to your capacity needs, available space, use/application and whether the tank is to be transported. (The Ace Roto-Mold Catalog details the available styles.) Be certain that you check the dimensional tolerances specified for the tank you select and that the installation allows for these tolerances. For close tolerance installations, it is recommended that you measure the actual tank to be used or that you verify dimensional values with the factory before constructions.

NOTE: Fittings are installed to a standard size and location as indicated in the product Catalog. If factory fittings are not required, this should be indicated on your order (e.g., "Send fittings loose.") If you request fittings to be installed that are not the standard size, that should be indicated on your order (e.g., "Install 3 inch fittings.") If standard locations are not acceptable or to insure proper placement of fittings, locate the tank diagram for the tank style to be ordered on pages 6-10. Specify each fitting location on the diagram according to the instructions provided. It is important to include these diagrams with your order to insure that the fittings are installed to your specifications.

- STEP 4** Review the Handling, Installation and Use Guidelines (pages 11-13).
- STEP 5** Contact Sales Support at Den Hartog Industries, Inc. 800-342-3408; or fax at 712-752-8222; or email: sales@denhartogindustries.com

CHEMICAL RESISTANCE DATA CHART

Chemical Resistance Key:

R - Resistant N - Not Resistant V - Variable Resistance U - Unknown

Caution Key:

(P) - Plasticizer (A) - Known Stress Crack Agent (O) - Oxidizer (B) - Suspected Stress Crack Agent

Chemical	70°F	140°F
	(21°C)	(60°C)
Acetaldehyde -100% (A)	V	N
Acetic Acid -10% (A)	R	R
Acetic Acid -60% (A)	R	V
Acetic Anhydride (B)	N	N
Aluminum Chloride - all conc.	R	R
Aluminum Fluoride - all conc.	R	R
Aluminum Sulfate - all conc.	R	R
Alums - all types	R	R
Ammonia - 100% dry gas	R	R
Ammonium Carbonate	R	R
Ammonium Chloride - sat'd.	R	R
Ammonium Fluoride - sat'd.	R	R
Ammonium Hydroxide - 10%	R	R
Ammonium Hydroxide - 28%	R	R
Ammonium Nitrate - sat'd.	R	R
Ammonium Persulfate - sat'd.	R	R
Ammonium Sulfate - sat'd.	R	R
Ammonium Metaphosphate - sat'd.	R	R
Amyl Acetate -100% (BP)	N	N
Amyl Alcohol - 100% (AP)	R	R
Amyl Chloride -100% (P)	N	N
Aniline - 100% (AP)	N	N
Aqua Regia (O)	N	N
Arsenic Acid - all conc.	R	R
Aromatic Hydrocarbons (BP)	N	N
Ascorbic acid -10%	R	R
Barium Carbonate - sat'd.	R	R
Barium Chloride - sat'd.	R	R
Barium Hydroxide	R	R
Barium Sulfate - sat'd.	R	R
Barium Sulfide - sat'd.	R	R
Beer	R	R
Benzene (BP)	N	N
Benzoic acid - all conc.	R	R
Bismuth Carbonate - sat'd.	R	R
Bleach Lye - 10%	R	R
Borax - sat'd.	R	R
Boric acid - all conc.	R	R
Boron Trifluoride	R	R
Brine	R	R
Bromine - liquid (O)	N	N
Butanediol 10% (A)	R	R
Butanediol - 60% (A)	R	R
Butanediol -100% (A)	R	R
Butter (B)	R	R
Butyl Acetate -100% (BP)	V	N
Butyl Alcohol -100% (A)	R	R
Butyric Acid - conc. (P)	N	N
Cadmium Salts	R	R

Chemical	70°F	140°F
	(21°C)	(60°C)
Calcium Bisulfide	R	R
Calcium Carbonate - sat'd	R	R
Calcium Chlorate - sat'd.	R	R
Calcium Chloride - sat'd	R	R
Calcium Hydroxide - conc.	R	R
Calcium Hypochlorite - bleach soln.	R	R
Calcium Nitrate - 50%	R	R
Calcium Oxide - sat'd.	R	R
Calcium Salts	R	R
Calcium Sulfate	R	R
Camphor Oil (BP)	N	N
Carbon Dioxide - all conc.	R	R
Carbon Disulphide	N	N
Carbon Monoxide	R	R
Carbon Tetrachloride (P)	N	N
Carbonic Acid	R	R
Castor Oil - conc. (A)	R	R
Chlorine -100% dry gas (O)	V	N
Chlorine Liquid (O)	N	N
Chlorine Water- 2% sat'd sol'n	V	R
Chlorobenzene (BP)	R	N
Chlorofoam (BP)	N	N
Chlorosulfonic Acid -100%	V	N
Chromic Acid - 10%	R	R
Chromic Acid - 50%	R	V
Cider (A)	R	R
Citric Acid - sat'd. (A)	R	R
Coconut Oil Alcohols (A)	R	R
Coffee	R	R
Cola Concentrates (A)	R	R
Copper Chloride - sat'd.	R	R
Copper Cyanide - sat'd.	R	R
Copper Fluoride - 2%	R	R
Copper Nitrate - sat'd.	R	R
Copper Sulfate - sat'd.	R	R
Corn Oil (A)	R	R
Cottonseed Oil (A)	R	R
Cresol - 100%	R	R
Cuprous Chloride - sat'd.	R	R
Detergents, synthetic (A)	R	R
Developers, photographic	R	R
Dextrin - sat'd.	R	R
Dextrose - sat'd.	R	R
Diazo Salts	R	R
Dibutylphthalate (B)	V	V
Dichlorobenzene (BP)	R	R
Diethyl Ketone (BP)	V	N
Diethylene Glycol (A)	R	R
Diglycolic Acid (A)	R	R
Dimethylamine	N	N

The information contained within this chart is based upon data supplied by resin manufacturers and is intended to be a general guide. Note that this data does not encompass all applications or service temperatures. For this reason, Den Hartog Industries, Inc. makes no claim as to the accuracy of this data and recommends that in all cases the final determination of suitability between the chemical(s) to be contained and the polyethylene tank material be verified with the chemical manufacturer(s).

CHEMICAL RESISTANCE DATA CHART

Chemical Resistance Key:

R - Resistant N - Not Resistant V - Variable Resistance U - Unknown

Caution Key:

(P) - Plasticizer (A) - Known Stress Crack Agent (O) - Oxidizer (B) - Suspected Stress Crack Agent

Chemical	70°F	140°F
	(21°C)	(60°C)
Disodium Phosphate	R	R
Emulsions, photographic (A)	R	R
Epsom Salts - Magnesium Sulfate	R	R
Ethyl Acetate -100% (BP)	V	N
Ethyl Alcohol -100% (A)	R	R
Ethyl Alcohol - 35% (A)	R	R
Ethyl Benzene (BP)	N	N
Ethyl Chloride (P)	N	N
Ethyl Ether (P)	N	N
Ethylene Chloride (BP)	N	N
Ethylene Glycol (A)	R	R
Fatty Acids (A)	R	R
Ferric Chloride - sat'd.	R	R
Ferric Nitrate - sat'd.	R	R
Ferrous Chloride - sat'd	R	R
Ferrous Sulfate	R	R
Fish Solubles (A)	R	R
Fluoboric Acid	R	R
Fluosilicic acid - conc.	R	V
Fluosilicic acid - 32%	R	R
Formic Acid - all conc.	R	R
Fructose - sat'd.	R	R
Fruit Pulp (B)	R	R
Furfural -100% (P)	N	N
Furfuryl Alcohol (BP)	N	N
Gallic Acid - sat'd. (A)	R	R
Gasoline (PB)	N	N
Glucose	R	R
Glycerine (A)	R	R
Glycol (A)	R	R
Glycolic Acid - 30% (A)	R	R
Grape Sugar- sat. ag	R	R
Heptane (PB)	N	N
Hexachlorobenzene	R	R
Hexanol, Tertiary (A)	R	R
Hydrobromic Acid - 50%	R	R
Hydrochloric Acid - all conc.	R	R
Hydrocyanic Acid - sat'd.	R	R
Hydrofluoric Acid - 40% (A)	R	R
Hydrofluoric Acid - 60% (A)	R	R
Hydrogen -100%	R	R
Hydrogen Chloride - dry gas	R	R
Hydrogen Peroxide - 30%	R	R
Hydrogen Sulfide	R	R
Hypochlorous Acid - conc	R	R
Inks (A)	R	R
Iodine - in KI Sol'n (O)	V	N
Lead Acetate - sat'd.	R	R
Lead Nitrate	R	R

Chemical	70°F	140°F
	(21°C)	(60°C)
Lime	R	R
Magnesium Carbonate - sat'd	R	R
Magnesium Chloride - sat'd.	R	R
Magnesium Hydroxide - sat'd.	R	R
Magnesium Nitrate - sat'd.	R	R
Magnesium Sulfate - sat'd.	R	R
Mercuric Chloride - 40%	R	R
Mercuric Cyanide - sat'd	R	R
Methyl Alcohol -100% (A)	R	R
Methylene Chloride -100% (PB)	N	N
Milk	R	R
Mineral Oils (P)	V	N
Molasses	R	R
Naphtha (PA)	V	N
Naphthalene (PB)	N	N
Nickel Chloride - conc.	R	R
Nickel Nitrate - sat'd.	R	R
Nickel Sulfate - conc.	R	R
Nicotine - dilute (A)	R	R
Nitric Acid - 0-30%	R	R
Nitric Acid - 30-50% (O)	R	V
Nitric Acid - 70% (O)	R	V
Nitric Acid - 95-98% (O)	N	N
Nitrobenzene -100% (PB)	N	N
Nonyl phenol ethoxylate (B)	N	N
Octane	R	R
Oxalic Acid - sat'd. (A)	R	R
Perchloroethylene (P)	N	N
Phosphorous Pentoxide	V	N
Photographic Solutions	R	R
Plating Solutions	R	R
Brass (A)	R	R
Cadmium (A)	R	R
Gold (A)	R	R
Nickel (A)	R	R
Silver (A)	R	R
Tin (A)	R	R
Zinc (A)	R	R
Potassium Acetate	R	R
Potassium Bicarbonate - sat'd.	R	R
Potassium Bromate -10%	R	R
Potassium Bromide - sat'd	R	R
Potassium Carbonate	R	R
Potassium Chlorate - sat'd.	R	R
Potassium Chloride - sat'd.	R	R
Potassium Chromate - 40%	R	R
Potassium Cyanide - sat'd	R	R
Potassium Dichromate - 40%	R	R
Potassium Ferri/Ferro Cyanide sat'd.	R	R
Potassium Fluoride	R	R
Potassium Hydroxide - 20%	R	R

The information contained within this chart is based upon data supplied by resin manufacturers and is intended to be a general guide. Note that this data does not encompass all applications or service temperatures. For this reason, Den Hartog Industries, Inc. makes no claim as to the accuracy of this data and recommends that in all cases the final determination of suitability between the chemical(s) to be contained and the polyethylene tank material be verified with the chemical manufacturer(s).

Ace Roto-Mold Polyethylene Tanks

Materials Information

Chemical Service Temperatures

Continued or prolonged service with certain chemicals at elevated temperatures may reduce the life of a polyethylene tank. The effects of the temperature on the polyethylene will depend on the chemical chemistry, chemical specific gravity, size and model of tank the chemical is to be stored in, and the tank wall thickness. Depending upon the chemicals to be stored, Ace Roto-Mold tanks will handle sustained temperatures of up to 120° F (49° C) and intermittent temperatures of up to 140° F (60° C). Consult the chemical manufacturer for recommendations regarding storage in polyethylene tanks and service temperature limits. Please note that higher service temperatures will lower the specific gravity rating of the tank.

Ultraviolet light exposure

Ace Roto-Mold tanks are molded from polyethylene compounded with the latest technology in ultraviolet (UV) light stabilizers. These UV stabilizers will reduce the harmful effects of ultraviolet light exposure and are intended to extend the life of a tank over similar materials that are not compounded with stabilizers. Our UV rating is “8,” which generally means that after 8000 hours of exposure to the sun, there will be 50% of UV protection remaining.

Environmental Stress Crack Resistance (ESCR Rating)

ESCR is a method utilized to evaluate or test processed polyethylene for stress crack resistance when exposed to a chemical for a given amount of time. Most polyethylene resins are rated according to an ESCR value that is specified in the material specifications data supplied by the resin supplier. Certain chemicals, although having no direct chemical effect on polyethylene, may accelerate cracking under mechanical stresses. Elevated temperatures may also effect polyethylene cracking. Although all processed polyethylene resins are subject to stress cracking, some are more resistant to it than others. Please reference the material data specifications for ESCR ratings for the tank model selected. To reduce the effect of ESCR proper care should be taken to reduce stress at fittings, bands, tie down lugs, etc.

Specific Gravity

Specific Gravity is the ratio of the chemical weight per gallon divided by the weight of water per gallon (8.33 lb. per gallon). As an example, if a chemical weighs 10 lb. per gallon, the specific gravity of the chemical is $10.0/8.33 = 1.2$. (Metric: kilogram/cubic meter or gram/liter) The Ace Roto-Mold standard tank has 1.7 specific gravity (see page 22 for a specific gravity conversion chart).

Material Color

The standard color for most Ace Roto-Mold tanks is natural (translucent white). Yellow is the standard color for crop care tanks, septic tanks, and liquid feeders. Spot sprayer and vertical tanks may be inventoried in both natural and yellow. Standard stock tanks are spruce green. All tanks may be ordered in non-standard colors such as yellow, black, or green as an option.

FDA Compliance

Ace Roto-Mold tanks are manufactured utilizing FDA compliant resins. Natural, black, and green colored tanks are in full compliance with current FDA standards for polyethylene tanks. However, certain colors (i.e. yellow) when blended into the resin, may effect this compliance. Consult the factory regarding other colors and FDA compliance. Please specify on your tank order if FDA compliance is required and we will assist in your selection.

NSF Compliance

National Sanitary Foundation (NSF) compliance considers a number of factors for approval. Among these are material and final configuration of the product including fittings and accessories that are exposed to the chemical. For this reason, please consult the factory regarding NSF approval.



Accessories Placement Diagram Large Vertical Style Tanks

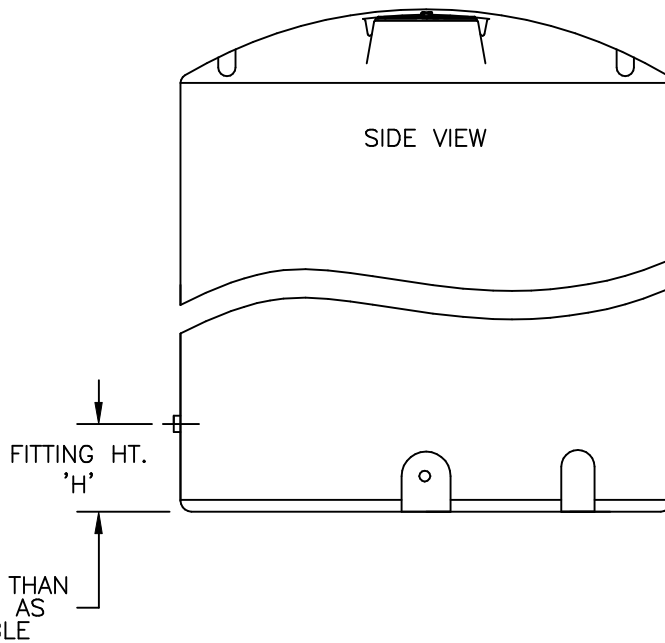
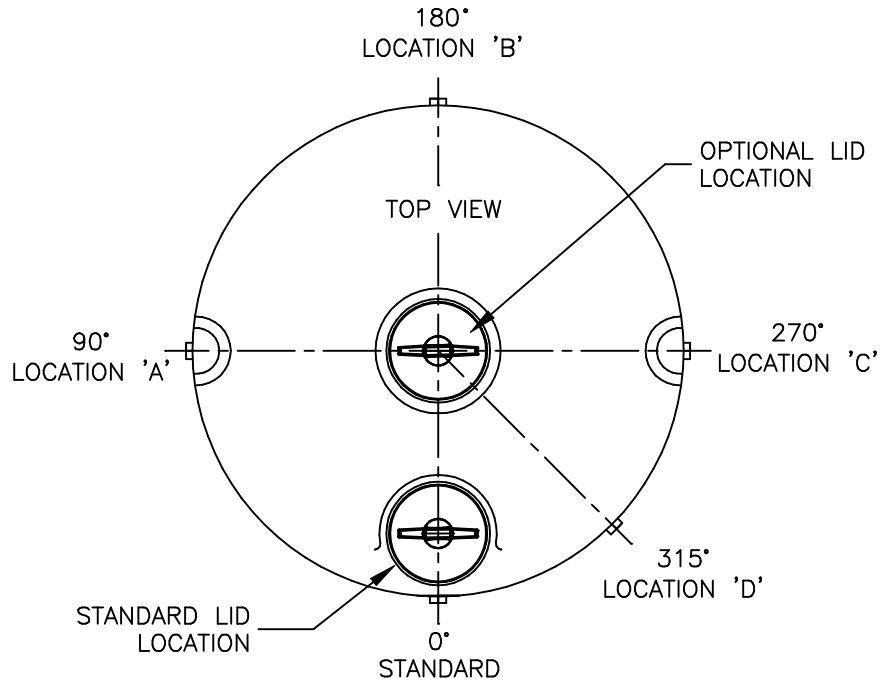

Fitting Size	Fitting P.N.	Lid Size (If Optional)	Lid P.N. (If Optional)	Fitting Location – Top View					Side View
				STD.	'A'	'B'	'C'	'D'	'H'



Accessories Placement Diagram Small Vertical Style Tanks

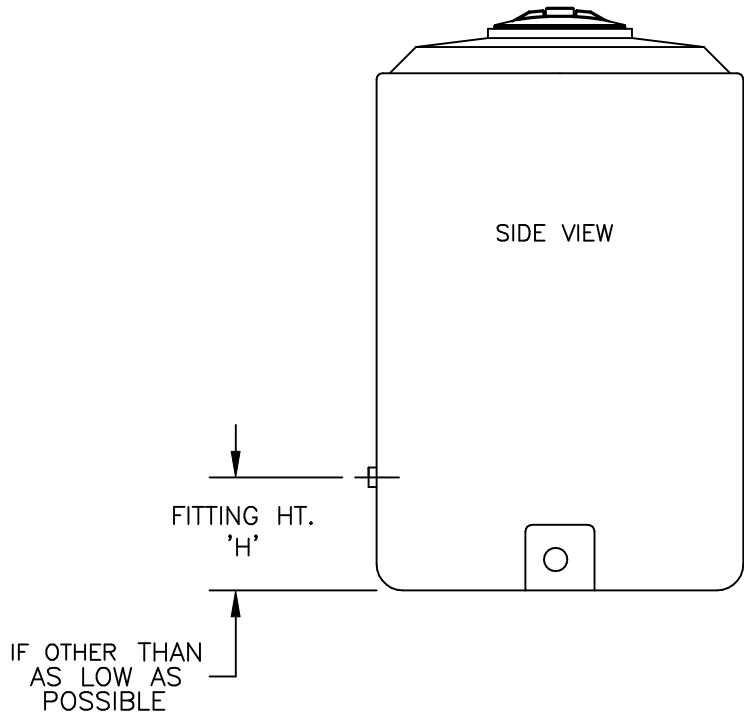
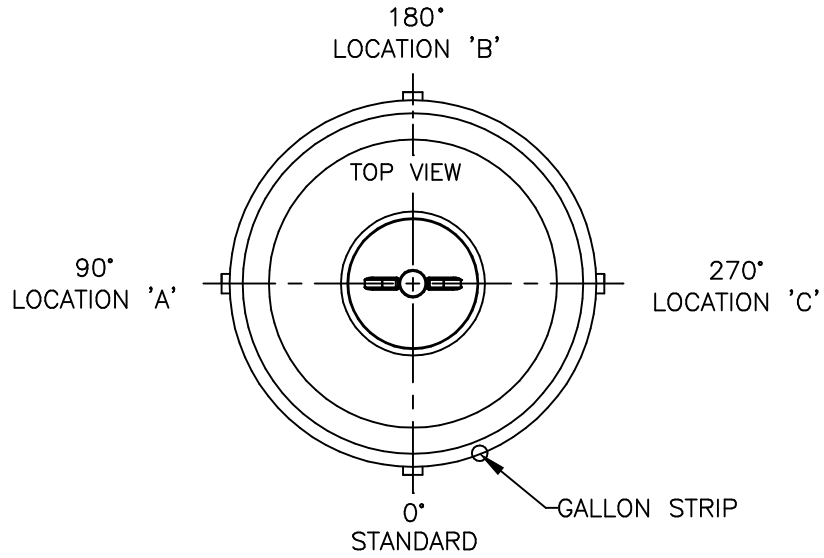

Fitting Size	Fitting P.N.	Lid Size (If Optional)	Lid P.N. (If Optional)	Fitting Location – Top View				Side View
				STD.	'A'	'B'	'C'	'H'



Accessories Placement Diagram Horizontal Style Tanks

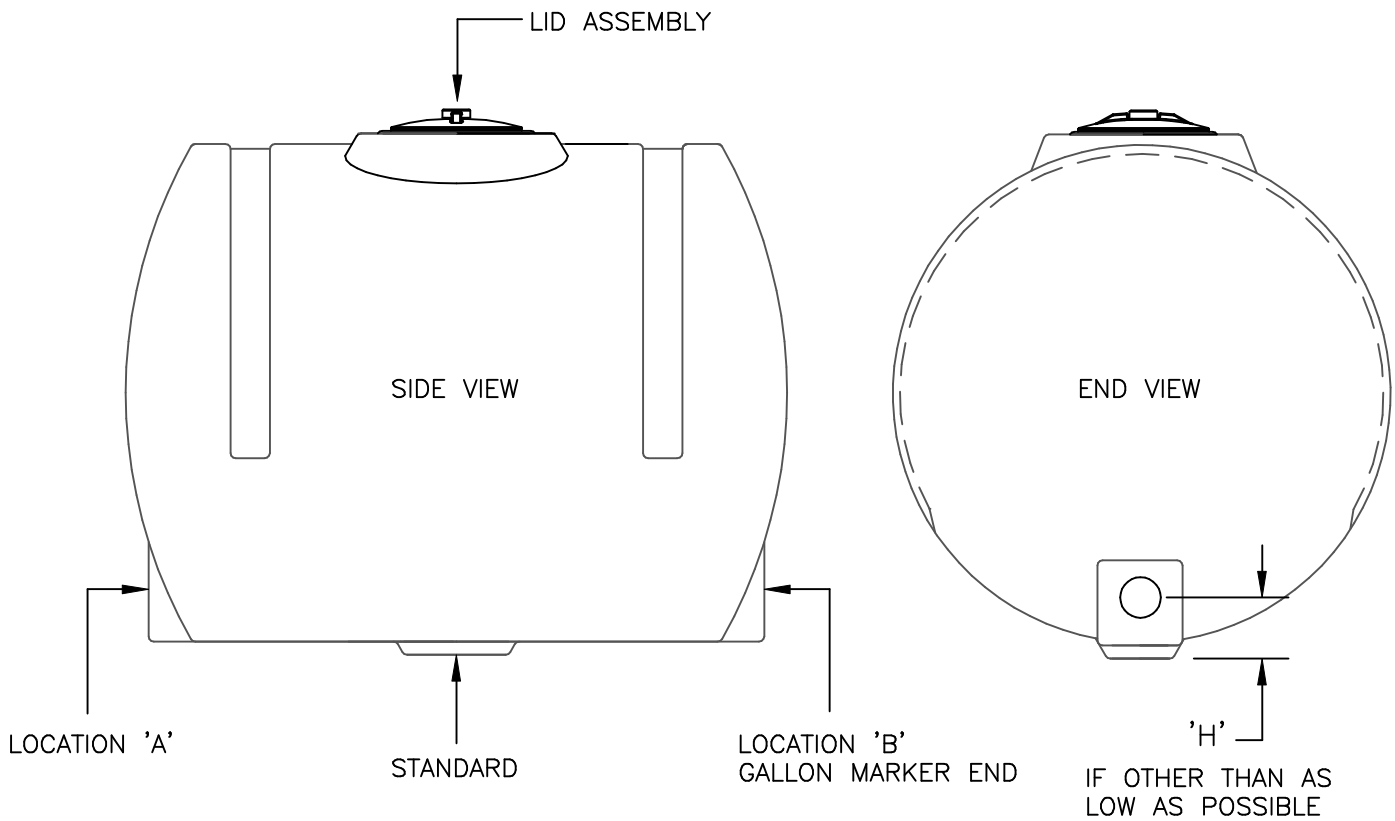

USE GALLON MARKERS AS REFERENCE TO LOCATE FITTING

Fitting Size	Fitting P.N.	Lid Size (If Optional)	Lid P.N. (If Optional)	Fitting Location – Side View				End View
				STD.	'A'	'B'	Other Specify	'H'



Accessories Placement Diagram Leg Style Tanks

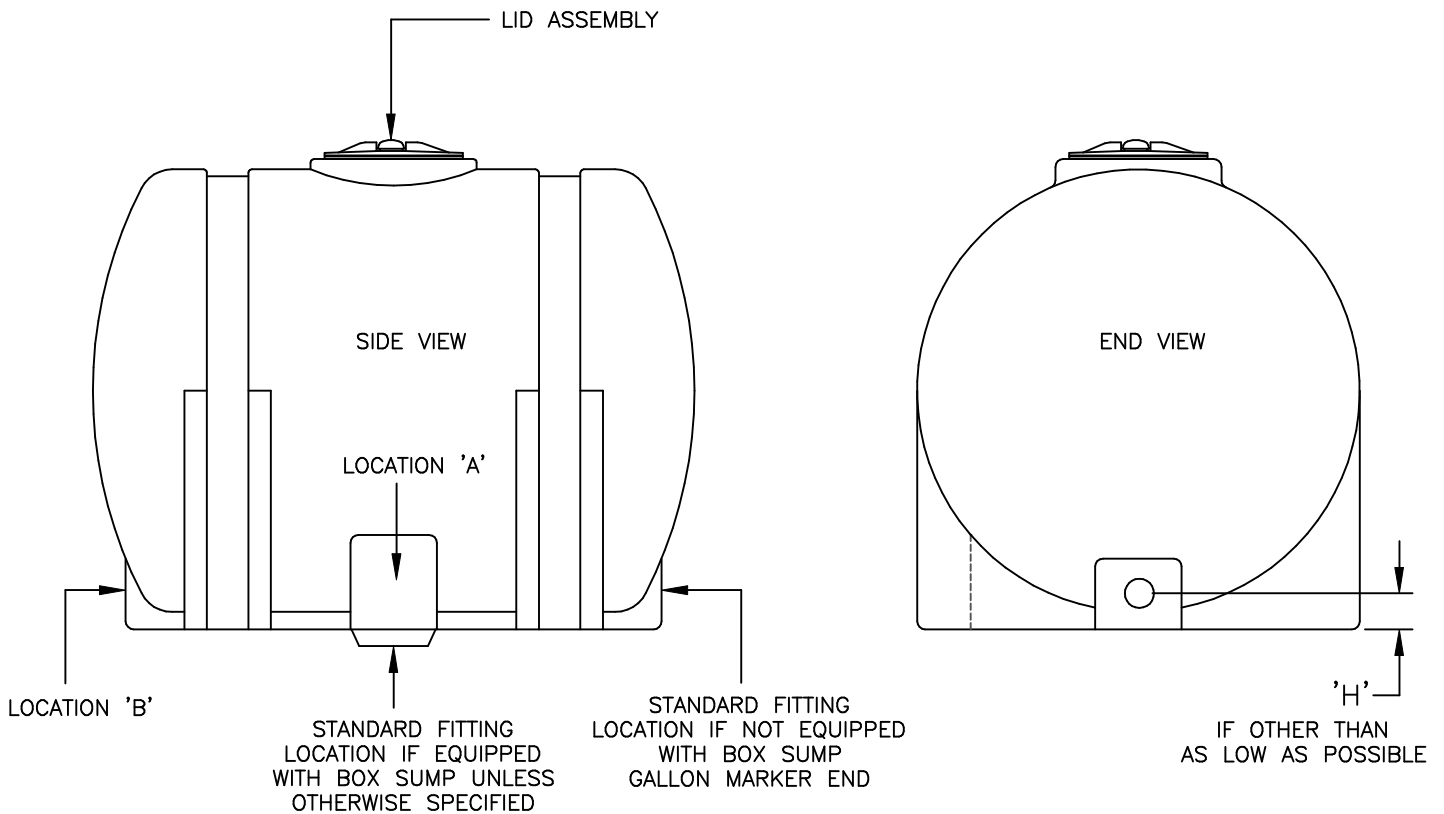

Fitting Size	Fitting P.N.	Lid Size (If Optional)	Lid P.N. (If Optional)	Fitting Location – Side View				End View
				STD.	'A'	'B'	Other Specify	'H'



Accessories Placement Diagram Cone Bottom Style Tanks

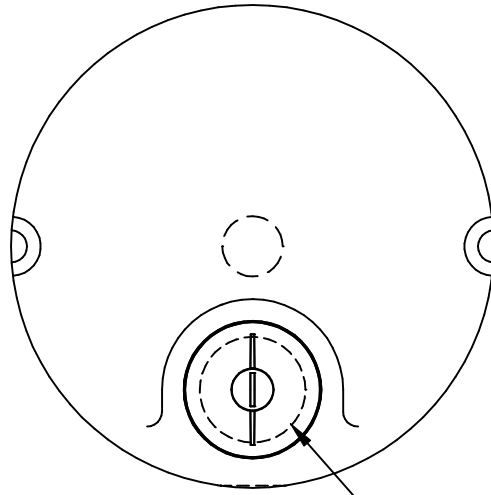

LID ASSEMBLY

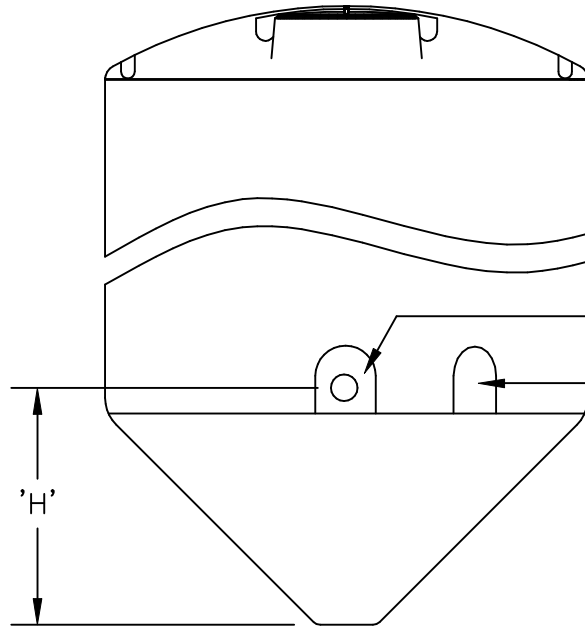

LOCATION 'A'

LOCATION 'B'

STANDARD

Fitting Size	Fitting P.N.	Lid Size (If Optional)	Lid P.N. (If Optional)	Fitting Location – Side View				End View
				STD.	'A'	'B'	Other Specify	'H'

Ace Polyethylene Tanks

Handling, Installation and Use Guidelines

Ace polyethylene tanks are designed to provide a safe and durable means for the containment of approved chemicals providing that the tanks are handled, installed, used and maintained according to the following guidelines. Consult Den Hartog Industries concerning any questions regarding these guidelines. Improper handling and installation can cause physical damage to tanks, fittings and accessories resulting in leakage and/or tank wall failure. Improper use and maintenance can result in reduced product life and leakage and/or tank wall failure. Failure to comply with the following product guidelines will void all factory warranty.

Damaged Product Claims:

Upon delivery, inspect the tank immediately for defects or shipping damage. Any damage or discrepancies must be noted on both the driver's bill of lading and your packing list. Claims must be made within 30 days. See page 16 regarding the return policy for damaged or defective products.

Unloading Tanks:

When unloading the tank, avoid contact with sharp objects such as lift forks or loader buckets that can cause damage, including tank wall puncture, if the proper precautions are not observed. Never allow tanks to be rolled over on the fittings. Large bulk storage tanks should be carefully unloaded with the use of a crane or another suitable lifting device. Insure that the unloading area is flat and free of large rocks, sharp objects or other objects that could damage the tank. Avoid unloading the tanks in high winds. Always support or brace tanks that are placed on their side to prevent rolling.

Tank Installation:

When selecting the tank site, insure that the site is level and that adequate drainage is provided for water runoff. The bottom of all tanks must be completely supported. Reinforced concrete support pads are recommended for tanks with capacities over 1000 gallons (3785 liters). In all cases be certain that the base material is designed to support the bearing capacity requirements of the tank, including seismic and wind loads. If the tank is installed in a stand or skid, note that the bearing capacity requirements of the concrete or soil will be increased. Always anchor the tank according to seismic or wind load zone requirements for the site. Always consult with the applicable building codes governing the tank site for specific support and anchoring requirements.

Tank Burial:

The only Ace Roto-Mold tanks designed for burial are the septic and cistern tanks. Other tanks are not designed to handle the pressure of surrounding earth and should not be buried.

Chemical Resistance:

Be certain that the tank, fittings, and fitting gasket materials are compatible with the chemicals to be contained and the anticipated storage temperatures. Refer to the Chemical Resistance Data Chart on pages 2-4 for the most commonly stored chemicals. Used motor oil is not recommended for storage in Ace Roto-Mold tanks due to contaminants. For applications not listed, consult the chemical supplier for storage recommendations in polyethylene tanks, or consult Den Hartog Industries.

Transportable Tanks:

Tanks that will be transported will require special consideration with regard to the dynamic loads introduced by starting, turning or stopping the tank and vehicle. Insure that the vehicle is designed for supporting and braking for the size tank selected, including the tank weight, capacity and the specific gravity of the chemical to be transported.

Horizontal cylindrical tanks, which are not free standing, must be fully supported around the bottom of the tank diameter by not less than 1/3 of the circumference. Freestanding tanks (tanks equipped with support legs) must be fully supported under the legs and open sump areas and be installed with hoops, which are securely anchored to a metal support skid. In all cases, the tank skid or stand must be adequately fastened to the vehicle bed to prevent shifting. Vertical bulk storage tanks are designed for stationary applications.

Fitting Installation:

Be careful not to over tighten poly fittings. If over tightened, these fittings can be damaged and leak. In such cases, always replace the fittings. If thread sealant is used, be certain that it is rated for use with the fittings and chemical to be contained. Never subject fittings to loads or weight that may cause cracking. Avoid rigid plumbing from tank fitting. Fitting installations to and from tank must consider the effects of expansion and contraction stresses due to temperature as well as filling and emptying of the tank. (See page 14 for general fitting installation guidelines)

Caution: Be particularly careful with fittings that are friction welded, often referred to as “spin welds”. These fittings can fail if attachments are not properly supported, are exposed to excessive vibration or are over tightened. Never hang long lengths of hose or pipe without support hangers to carry the dead weight of the hose or pipe. Filters, valves and couplings will need to be supported so the loads are not transferred to the “spin weld” fitting.

- **Dry Fittings** – Fittings that are not exposed to chemicals and have no low temperature limit providing the plumbing loads that the fittings are subjected to are within the Application Guidelines recommendations.
- **Wet Fittings** – Fittings that are exposed to chemicals will have a low temperature rating equivalent to the freezing limits of the chemical the fitting is exposed to. In the case of water that would be 32° F (0° C) ambient. Chemicals or solutions such as calcium chloride are generally rated for -20° F (-29° C) depending upon the salt concentration. Note that heaters, heat bands or chemical inhibitors that prevent chemical freeze up will allow the fittings to be exposed to ambient temperatures below the published freeze point of the chemical. Again, the low temperature rating of all fittings must be above the point at which the chemicals freeze or solidify.

Testing Prior to Installation:

Never fill a newly installed tank with chemical without first testing the tank, fittings and installation with a non-hazardous chemical such as water. This procedure will also serve to rinse out the tank and connections. Test the installation at full capacity for a minimum of 4 hours. Note that tank warranty does not cover any fluid losses. See warranty on page 17.

Proper Venting:

All tanks must be vented for atmospheric pressure as well as pressure created by filling and emptying the tank. Never attempt to fill or empty a tank without adequate venting. Keep vent clear of any ice or snow that may restrict ventilation. Tanks that are 142” in diameter require additional venting beyond what is provided by a vented lid.

Securing Rectangular Tanks:

The flat sides of rectangular or square tanks greater than 18” wide or high must be securely supported according to the specific gravity of the chemical stored and application temperature. Support all tanks that are to be transported.

PU0205-52 and PU0305-60 Pickup Tank Support Recommendations:

It is recommended that in all applications the tanks have sidewall support as illustrated in Fig. 1. In applications where the chemical to be contained has a specific gravity rating above 1.0 (greater than water) it is recommended that the sides be supported as illustrated in Fig. 2. Failure to properly support the tanks as recommended will cause excessive deflection and the possibility of failure and void all warranty.

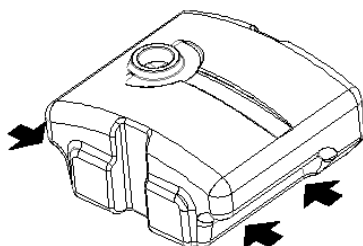

Fig. 1

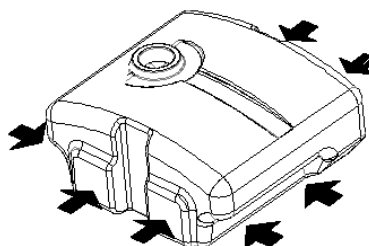

Fig. 2

Equipment Installation:

Never install heavy equipment on the tank walls. Consult the equipment manufacturer for recommendations regarding installation on polyethylene tanks of the size selected.

Submerged Heater Installation:

Submerged heaters must be installed with a minimum of 4" of clearance from the tank walls. Never allow the heater to contact the walls of the tank. Consult the heater manufacturer for recommendations regarding installation of the heater in polyethylene tanks.

Protect Tank Walls from Impact:

Insure that the tank walls are protected from impacts, especially at temperatures below 40° F (4° C).

Warning: Do not walk on the tank surfaces. Surfaces may be slippery. Serious injury or death could occur. Always follow OSHA regulations when working on or around tank systems.

Warning: Never enter a tank without first taking the proper safety precautions. Serious injury or death could occur. Consult with the chemical supplier regarding recommendations as well as the appropriate safety equipment required for handling the chemicals to be stored. Always follow OSHA regulations when working on or around tank systems.

Secondary Containment Requirements:

Consult the appropriate governing agency regarding secondary containment requirements for the tank selected and the chemicals to be stored.

Fitting Installation Guidelines

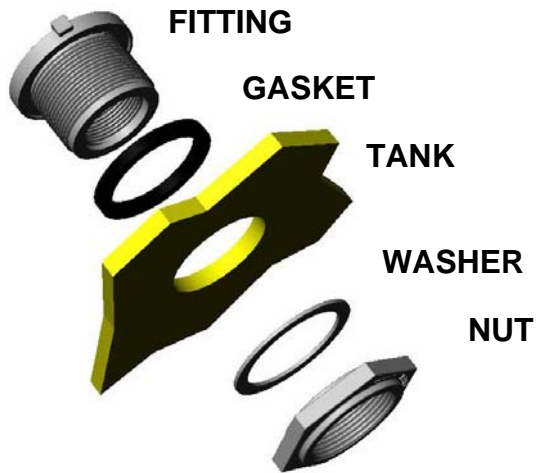

- Drill hole as straight as possible through tank at fitting location— recommend using hole saw at smallest diameter possible. Be careful not to drill hole too close to edge of sump or tank bottom. Wall thickness variation must not exceed .050” at the sealing surface of the fitting gasket.
- Deburr edge of hole on both sides to allow smooth sealing surface
- One gasket between fitting and tank, one washer between nut and tank
- Tighten nut to hand-tight plus ½ turn

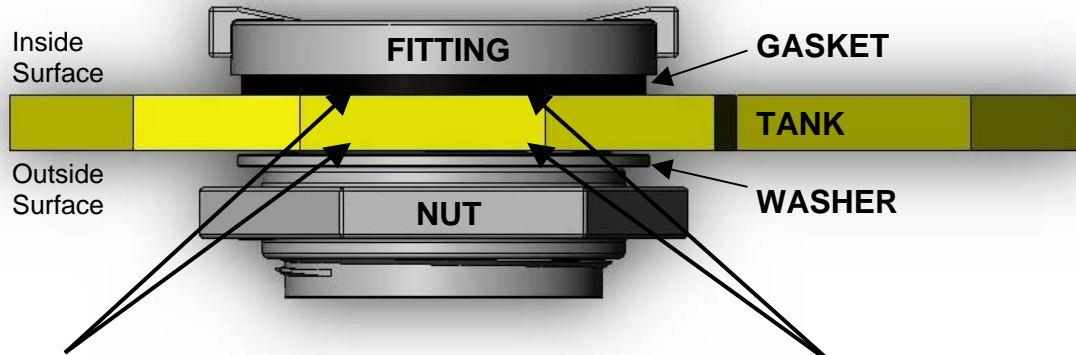

- Must remove burr and any shavings on tank surface to allow gasket to seal properly
- Do NOT deburr too much material around opening – only remove lip from saw cut, do not carve extra material out

NOTES:

- Edge of drilled holes for fittings must be at least 1” from adjacent surface or radius to allow sufficient space for gasket and washer to seal.
- Washer is not provided with all fittings.

GENERAL INFORMATION

PRICING AND TERMS

Terms: Standard payment terms are 2%/10 days, net 30 days.
Financial charges (1-1/2% per month/18% APR) are applied to late payments.

Price: Prices are subject to change without notice. Prices are in U.S. Dollars.

Sales Tax: All domestic applicable state and local taxes will be added to your invoice unless a certificate of sales tax exemption is provided in advance to Den Hartog Industries, Inc.

PRODUCT PERFORMANCE

Chemical Compatibility: Always verify your chemical compatibility with tanks, fittings, and gaskets. Consult your chemical manufacturer regarding applications.

Volume/Size Disclaimer: Volume and unit measurements are subject to variances due to thermal expansion and contraction and general molding tolerances.

SHIPPING AND TRANSPORTATION

Freight: FOB factory, Hospers IA. Special freight arrangements and billing are available. Truckloads are the most economical freight arrangements. The Den Hartog Industries, Inc. truck fleet is also available for economical freight arrangements.

Shipping charges:

Common and/or Contract Carriers –

Prepaid: We will request freight quotes and also dispatch the carrier. The customer will be billed the quoted shipping rate plus a small administration markup (5-10%).

Collect or 3rd Party Billing: Customers request collect or 3rd party billing. We cannot request rate quotes, as the freight companies will not release rates. We will call the carrier to dispatch for load pick-up. The freight company will bill the proper party (not Den Hartog Industries, Inc.).

UPS/Fed Ex/Speedee – Quotes are based upon published rates and priced at time of shipment. Oversized charges may apply. Items not boxed will require additional packaging and handling charges as applied by the carrier.

Den Hartog Trucking – Upon availability, Den Hartog Industries, Inc.'s fleet of trucks is the most economical way to ship full truckloads. Customers are billed on a per mile basis and fuel surcharges, oversize charges, and tolls or other road use charges may also apply.

Package & Handling charges:

Any individually shipped product that requires protective packaging (cardboard or shrink-wrap) will be assessed a minimum charge of \$2.00 per item. There will be an additional charge of \$.02/gallon for items with capacity over 100 gallons.

Floats – Additional loading and handling charge of \$1.00 per float.

Pallet charges – \$5.00 per pallet

Other Freight Policies:

- Insured Freight:** Insured shipments must be arranged and are billable to the customer.
- Drop Ship Charges:** Den Hartog Transportation: \$50 per drop location
Other carriers: Quotes upon request
- Oversize Charges:** Den Hartog Transportation: additional cost per mile
Other carriers: Quotes upon request
- Fuel Surcharges:** Carriers may attach an additional charge for fuel costs.

NOTE: Upon delivery, any quantity discrepancies or shipping damage should be noted on the packing slip prior to signing for the shipment.

LOAD PLANNING

Customers see a definite advantage when products can be shipped via Den Hartog's trucks. To maximize this advantage and reduce costs for both the company and the customer, we plan shipping based on full truckloads. General knowledge of load limitations can be used by the customer when ordering to save on shipping costs.

In general, 20,000 gallons of product fills a tank truck, while 16,000 gallons fills van trailers. Here are some examples of other full truckloads:

- 2 12,500-gallon tanks fill a lowboy trailer, with room to spare for some smaller tanks
- 3 10,500-gallon tanks fill a lowboy trailer, with room to spare for some smaller tanks
- 3 7800-gallon tanks fill a lowboy, with room to spare for some smaller tanks
- 4 7000-gallon tanks fill a lowboy, with room to spare for some smaller tanks
- 3 6000-gallon tanks fill a flatbed, with room to spare for some smaller tanks
- 4 5000-gallon tanks fill a flatbed
- 4 4200-gallon tanks fill a flatbed, with room to spare for some smaller tanks
- 5 4000-gallon tanks fill a lowboy, with room to spare for some smaller tanks
- 6 3000-gallon tanks fill a flatbed
- 7 2500-gallon tanks fill a flatbed
- 8 2000-gallon tanks fill a flatbed
- 13 1300-1650 gallon tanks fill a flatbed

RETURNED GOODS POLICIES & WARRANTIES

Prior authorization is required for any product returns. Please contact a Den Hartog Industries, Inc. representative within 30 days for details and instructions for making warranty claims for returned goods authorizations. An RGA number will be issued. Also, freight arrangements and other instructions will be provided. **Product shipped back to DHI freight collect without prior authorization will NOT be accepted.**

Returned goods are approved upon review if the cause is for a material or manufacturing defect, or a warranty claim. Account credits will be issued after the products are inspected and account adjustments are authorized. **Unauthorized debits on account payments will not be allowed.** Unless an approved credit memo has been issued by Den Hartog Industries, Inc., all unauthorized debits will be considered short payment and will be subject to finance charges as unpaid balances.

Den Hartog Industries, Inc. does not authorize labor or handling charges for warranty or returned goods. Den Hartog's credit policy applies only to the product itself. Pre-existing contractual supplier agreements will be honored.

The text of Den Hartog Industries, Inc.'s limited warranty and disclaimer on Ace Roto-Mold products appears on the following pages. Note that the general warranty period is 36 months for most poly tanks. However, the warranty for poly livestock tanks is limited to 24 months. Please read the warranty and disclaimer for all details.



LIMITED WARRANTY POLYETHYLENE TANKS

1. Extent and Duration of this Warranty:

Your Den Hartog polyethylene tank is warranted to be free from defects in materials and workmanship under normal use and service for the following periods after date of purchase by the original owner when properly installed, used and maintained:

Poly Stock Tanks:	24 months
Septic/Cistern Tanks:	60 months
Other Poly Tanks:	36 months

Any Den Hartog polyethylene tank product found to be defective in materials or workmanship will be dealt with under the repair and replacement procedure described in this policy.

THIS WARRANTY DOES NOT APPLY TO ANY COMPONENT PARTS OR ACCESSORIES USED WITH THE TANK THAT ARE NOT MANUFACTURED BY DEN HARTOG INDUSTRIES, INC.

2. Manufacturer and Warrantor:

Den Hartog Industries, Inc.
4010 Hospers Drive South
P.O. Box 425
Hospers, IA 51238-0425
(712) 752-8432

3. Repair or Replacement Procedure:

If your Den Hartog polyethylene tank product develops a defect during the warranty period, promptly notify our customer service department. Until such notice is received warrantor will not be responsible for any repair, replacement, or partial refund. Notice received more than sixty (60) days after the warranty period will not be valid and the warranty will not apply.

Upon receipt of timely notice from you, and proof of defect, warrantor will have a choice of options at its sole discretion.

- a) Warrantor may require you at your own expense to deliver or ship the product to its factory or authorized dealer. Any defective, warranted product will be repaired or replaced and returned to you or your authorized dealer free of charge. Any part returned to warrantor, and found not to be defective, will be returned to you freight collect with explanation.
- b) Warrantor may ship a new product to its dealer to be exchanged free of charge for the defective product returned by you.
- c) Warrantor may ship or deliver a replacement product to you at your address.
- d) Warrantor may refund the product's pro-rated value based on normal life span upon return of the product to it or its authorized dealer.
- e) Warrantor may choose another, reasonable procedure to compensate the purchaser.

4. **Limitations on Warranty Coverage:**

Coverage under this warranty will be effective only when a copy of the original invoice, showing date and location of purchase, accompanies any claim for warranty.

Warrantor has no liability whatsoever and this warranty is null and void if any Den Hartog product has been misassembled or subjected to neglect, negligence, misuse, accident or used in any way contrary to use and maintenance instructions.

This warranty does not cover any product that has been altered or modified so as to affect the product's use, performance or durability, or that has been modified to change the intended use of the product.

In addition, the warranty does not extend to repairs made necessary by abnormal use, damage, unreasonable use including failure to provide reasonable and necessary maintenance, by use of parts, accessories or other equipment which are incompatible with Den Hartog product, including but not limited to state of the art changes, without assuming any obligation to modify any product previously manufactured.

Warrantor has a policy of continuous product improvement. We reserve the right to change or improve design of any Den Hartog product, including but not limited to state of the art changes, without assuming any obligation to modify any product previously manufactured.

5. **Implied Warranties Excluded:**

All implied warranties are expressly excluded.

6. **Limitation of Consequential Damages:**

Warrantor's responsibility under this warranty extends solely to repair or replacement of your Den Hartog product and its component parts. Warrantor does not assume responsibility for, nor shall it be liable for, any special, incidental or consequential damages. Specifically, warrantor assumes no responsibility to the owner for loss of use of the product, loss of time, inconvenience or other damage consequential or otherwise, including, but not limited to loss of revenue or earnings; expense of transporting the product; travel time; telephone, fax, overnight delivery, or postage charges; road service/towing charges; rental during the time warranty repairs are being performed; travel or lodging costs; loss of damage to personal property; or any other losses.

Some states do not allow exclusion or limitation of incidental or consequential damages, so above exclusion or limitation may not apply to you.

7. **Purchaser's Rights:**

This warranty gives you specific legal rights, and you may also have other rights, which vary from state to state.

8. **Exclusive Warranty:**

This is the only warranty made by the warrantor on the product and no agent, employee, or other person is allowed to change or add to this warranty. This warranty extends solely to repair or replacement of your Den Hartog product. Warrantor does not assume any liability or responsibility not expressly covered by this limited warranty. This warranty supersedes all other warranties, written or implied.

No other express warranty has been made or will be made on behalf of warrantor with respect to this Den Hartog product or its construction, use, repair, or replacement.



**4010 HOSPERS DRIVE SOUTH, P.O. BOX 425
HOSPERS, IA 51238**

**LIMITED WARRANTY AND DISCLAIMER
POLY STOCK TANKS**

Den Hartog Industries, Inc., hereafter referred to as Manufacturer, does hereby declare this to constitute an express **WARRANTY** of its Ace Roto-Mold poly stock tanks. Said tanks shall be free from defects in workmanship and material under normal use, service and maintenance within the guidelines for installation, maintenance, and instructions for use provided by Manufacturer. This limited **WARRANTY** shall be in effect for 24 months following the date of manufacture. Manufacturer's liability upon proof of a defect in workmanship or materials within the **WARRANTY PERIOD** shall be limited to the replacement or the repair of the poly stock tank(s) or any part thereof or, at Manufacturer's option, the refunding to Buyer the pro-rated value of the poly stock tank(s) upon the return of the defective poly stock tank(s) to Manufacturer. No other express warranty is given and no agent, employee or any representative of Manufacturer is authorized to bind Manufacturer for any other warranty.

This **WARRANTY** shall not apply to or cover component parts or accessories manufactured by someone other than the Manufacturer. The manufacturer of such items may provide warranties with its products; however, Den Hartog Industries Inc. shall not be liable under those warranties.

This **WARRANTY** shall not apply with respect to any defect that in Manufacturer's sole judgment has arisen from the alteration or repair by anyone other than the Manufacturer or from damage in an accident, during shipment, or caused by negligence or misuse. This **WARRANTY** shall not be applicable if Buyer failed to follow any of the instructions for installation, maintenance and use provided by Manufacturer.

The amount of the Manufacturer's liability under this **WARRANTY**, irrespective of whether such defects are discoverable or latent, shall not exceed the pro-rated value of the particular poly stock tank(s) in which the defect occurred or, at the option of the Manufacturer, the replacement or the repair of the damaged or defective poly stock tank(s). Manufacturer shall not be liable for any incidental or consequential damages, including those that may arise as the result of a claim of negligence on the part of the Manufacturer or any other party. Manufacturer shall not be liable for any commercial losses or costs of any kind resulting therefrom.

This **WARRANTY** shall constitute an express **WARRANTY** and shall be the sole and exclusive remedy of any Buyer, there being no implied **WARRANTY** of merchantable quality or that the product is fit for any particular purpose.

Notice of any claim under this **WARRANTY** shall be given by registered mail sent to Manufacturer at Den Hartog Industries, Inc.; 4010 Hospers Drive South; Hospers, IA 51238. Such notice must be given within thirty (30) days after the claim first arises or the defect is first discovered. Instead of and in lieu of the notice provided, the defective poly stock tank(s) may be returned to the Manufacturer at the same location freight pre-paid. If notice by mail or return of the defective tank(s) are not completed within thirty (30) days after the defect arises or is discovered, this **WARRANTY** shall be deemed waived and unenforceable, and Manufacturer shall not be liable under the terms of this **WARRANTY**.

Conversion Charts and Formulas

METRIC SYSTEM

LENGTH - Basic unit is a meter

Metric Unit	Meters	Inches	Feet	Yards	Miles
Millimeter (mm)	.001	-	-	-	-
Centimeter (cm)	.01	.3937	-	-	-
Decimeter (dm)	.1	3.937	.3281	.1094	-
Meter (m)	1	39.37	3.281	1.094	-
Decameter (dkm)	10	393.7	32.81	10.94	-
Hectometer (hm)	100	3937	328.1	109.4	-
Kilometer (km)	1000	-	3281	1094	.6214

To convert

Inch to mm - multiply by 25.4
 mm to inch - multiply by .03937
 feet to meters - multiply by .3048
 Meters to feet - multiply by 3.281
 Yards to meters - multiply by .9144
 Meters to yards - Multiply by 1.094
 Miles to km - multiply by 1.609
 km to miles - multiply by .6214

Area - Basic unit is centare (ca) which is one square meter

Metric Unit	Centares	Square Inchces	Square Feet	Square Yards	Acres
Sq. Millimeter(sq. mm)	0.000001	-	-	-	-
Sq. Centimeter(sq. cm)	0.0001	0.1550	-	-	-
Sq. Decemeter(sq. dm)	0.01	15.50	0.1076	-	-
Centare/sq. meter (ca/sq m)	1	1550	10.76	1.196	-
Are (a)	100	-	1076	119.6	-
Hectare (ha)	10,000	-	-	-	2.471
Sq. Kilometer(sq. km)	1,000,000	-	-	-	247.1

To convert

Sq. in. to sq. cm - multiply by 6.452
 Sq. cm to sq. in. - multiply by .1550
 Sq. Ft. to sq. m. - multiply by .0929
 Sq. m. to sq. ft. - multiply by 10.76
 Sq. yds to sq. m. - multiply by .8361
 Sq. m. to sq. yds. - multiply by 1.196
 Acres to Hectares - multiply by .4047
 Hectares to Acres - multiply by 2.471
 Acres to sq. km - mukltiply by .004047
 Sq. km to Acres - multiply by 247.1
 Sq. miles to sq. km - multiply by 2.590
 Sq. km to sq. miles - multiply by .3861

Specific Gravity of Liquids

Specific gravity is the ratio of chemical weight per gallon divided by the weight of water per gallon.

Liquid	Temp °F	Specific Gravity
Water (1 cu. Ft. weighs 62.41 lb)	50	1.00
Brine (Sodium Chloride 25%)	32	1.20
Pennsylvania Crude Oil	80	0.85
Fuel Oil No. 1 and 2	85	0.95
Gasoline	80	0.74
Kerosene	85	0.82
Lubricating Oil SAE 10-20-30	115	0.94

Liquid	Temp °F	Specific Gravity
30% Acetic Acid	68	1.04
50% Acetic Acid	68	1.05
20% Chromic Acid	68	1.16
20% Hydrogen Peroxide	68	1.07
25% Methyl Alcohol	68	0.96
10% Nitric Acid	68	1.05
20% Nitric Acid	68	1.11

Liquid	Temp °F	Specific Gravity
20% Phosphoric Acid	68	1.11
20% Dsodium Hydroxide	68	1.21
50% Sodium Hydroxide	68	1.52
20% Sulphuric Acid	68	1.14
50% Sulphuric Acid	68	1.40
98% Sulphuric Acid	68	1.83

1 Gallon = 3.7854 liters

1 liter = 0.26417 gallons

VOLUME - Basic unit is stere (s) which is 1 cubic meter

Metric Unit	Steres	Cubic Inch	Cubic Foot	Cubic Yards
Cu. Millimeter (cu mm)	.000000001	-	-	-
Cu. Centimeter (cu cm)	.000001	.06102	-	-
Cu. Decimeter (cu dm)	.001	61.023	-	-
Desistere (ds)	.1	6102.3	3.531	.1308
Stere/Cu Meter (s/cu m)	1	61023	35.31	1.308
Decastere (dks)	10	-	353.1	13.08

To convert

Cu. In. to Cu. Mm - multiply by 1639
 Cu. Mm to Cu. In. - multiply by .000061
 Cu. M to Cu. Ft - multiply by 35.31
 Cu. In. to Cu. cm - multiply by 16.39
 Cu. Yards to Cu. M - multiply by .7646
 Cu. Cm. To Cu. In.- multiply by .06102
 Cu. M to Cu. yds - multiply by 1.308

Weight - Basic unit is gram (g)

Metric Unit	Grams	Grains	Ounces	Pounds
Milligram(mg)	0.001	0.01543	-	-
Centigram (cg)	0.01	0.1543	-	-
Decigram (dg)	0.1	1.543	-	-
Gram	1	15.43	0.03527	-
Decagram (dkg)	10	154.3	0.3527	-
Hectogram (hg)	100	1543	3.527	0.22046
Kilogram (kg)	1000	-	35.27	2.2046
Quintal (q)	100,000	-	3527	220.46
Metric Ton (MT)	1,000,000	-	-	2204.6

To convert

g to cg - multiply by 6.48
 cg to g - multiply by .1543
 Ounces to g - multiply by 31.103
 kg to Pounds - multiply by 2.2046
 g to Ounces - multiply by .03527
 Pounds to kg - multiply by .4536
 kg to Pounds - multiply by 2.2046
 Tons(2000#) to Metric Tons - multiply by .9078
 Metric Tons to Tons(2000#) - multiply by 1.1023

Conversion Charts and Formulas

Conversion Constants

To Change	To	Multiply By
Inches	Feet	0.0833
Inches	Millimeters	25.4
Feet	Inches	12
Feet	Yards	0.3333
Yards	Feet	3
Square Inches	Square Feet	0.00694
Square Feet	Square Inches	144
Square Feet	Square Yards	0.11111
Square Yards	Square feet	9
Cubic Inches	Cubic Feet	0.00058
Cubic Feet	Cubic Inches	1728
Cubic Feet	Cubic Yards	0.03703
Cubic Yards	Cubic Feet	27
Cubic Inches	Gallons	0.00433
Cubic Feet	Gallons	7.48
Gallons	Cubic Inches	231
Gallons	Cubic Feet	0.1337
Gallons	Pounds of Water	8.337
Pounds of Water	Gallons	0.12004
Ounces	Pounds	0.0625
Pounds	Ounces	16
Inches of Water	Pounds per sq. Inch	0.03609

Flow

1 gpm	= 0.134 cu. Ft. per min.
	= 500 lb. per hr. x sp. Gr.
500lb. Per hr.	= 1 gpm / sp. Gr.
1 cu. Ft. per min. (cfm)	= 448.8 gal. Per hr. (gph)

Pressure

1 lb. Per sq. in.	= 2.31 ft. water at 60°F
	= 2.04 in. hg at 60°F
1 ft. water at 60°F	= 0.4333 lb. Per sq. in.
	= 0.884 in. hg at 60°F
1 in. Hg at 60°F	= 0.49 lb. Per sq. in.
	= 1.13 ft. water at 60°F
1 lb. Per sq. in.	= lb. Per sq. in. gauge (psig)+ 14.7 Absolute (psia)

To Change	To	Multiply By
Inches of water	Inches of Mercury	0.0736
Inches of water	Ounces per sq. inch	0.578
Inches of water	Pounds per sq. foot	5.2
Inches of Mercury	Inches of Water	13.57
Inches of Mercury	Feet of Water	1.131
Inches of Mercury	Pounds per sq. inch	0.4898
Ounces per sq. inch	Inches of Mercury	0.17
Ounces per sq. inch	Inches of Water	1.73
Pounds per sq. inch	Inches of Water	27.71
Pounds per sq. inch	Feet of water	2.309
Pounds per sq. inch	Inches of Mercury	2.042
Pounds per sq. inch	Atmosphere	0.06805
Feet of water	Pounds per sq. inch	0.4331
Feet of water	Pounds per sq. foot	62
Feet of water	Inches of Mercury	0.8843
Atmosphere	Pounds per sq. inch	14.70
Atmosphere	Inches of Mercury	29.92
Atmosphere	Feet of water	34
Long Tons	Pounds	2240
Short Tons	Pounds	2000
Short Tons	Long Tons	0.89

Temperature

°C	= (°F - 32) x 0.556
°F	= C(1.8) + 32

Volume

1 gal. (US)	= 128 fl. Oz. (US)
	= 231 cu. In.
	= 0.833 gal. (Brit.)
1 cu. Ft.	= 7.48 gal. (US)

Mass

1 lb. (avoir)	= 16 oz. (avoir)
	= 7000 grain
1 ton (short)	= 2000 lb.
1 ton (long)	= 2240 lb.

Specific Gravity Conversion Chart

Material Weight In Lbs/Gal	Specific Gravity
8	0.96
9	1.08
10	1.20
11	1.32
12	1.44
13	1.56
14	1.68
15	1.80
16	1.92
17	2.04

Specific Gravity	Material Weight In Lbs/Gal
1.5	12.50
1.6	13.33
1.7	14.16
1.8	14.99
1.9	15.83
2.0	16.66

EXAMPLES

Water 8.33# SPG 1

Brine 6.14# SPG 0.74

Feric Chloride 11.75# SPG 1.41

Sodium Hydroxide 17.74# SPG 2.13

Significant Part Number Matrix Rev.00

TD = Tear Drop
 OT = Oval Tank
 OC = Open Top Cone Bottom
 IB = Inductor Blow Mold
 ACT = Aquifer
 ST = Stackable Tote
 LP = Low Profile
 WO = Water Only
 IB = Inductor Blow Mold
 PM = PCO w/ Sump
 PC = PCO w/o Sump
 CM = Crop Care Box Sump
 CC = Crop Care Std. Sump
 HE=Elliptical
 SB=Spot Spray blow mold
 SF=Spot Spray no sump foam
 SD=Spot Spray no sump dual
 FM=Free Stand
 SM=Spot Spray w/Sump
 CW=Cut Away w/Sump
 GV=Gusset
 IS=Inductor - Side mount
 IN=Inductor
 OP=Open Top
 FS=Free Stand no sump
 SS=Spot Spray no sump
 SP=Specialty
 PU=Pickup
 CB=Cone Bot.
 HZ=Horizontal
 VT= Vertical

S = Standard (or ACT ship Lid)
 L = 16" Ground Access Lid (ACT)
 G = 28" Ground Access (ACT)
 B = Largest (or ACT Burial Lid)
 O = Off Center Sump
 C = Center Sump
 B = Largest
 A = Smallest
 X = Special request

T=20% HVY W/ CODE 5
 R=10% HVY W/ CODE 5
 Q=STD. WGT W/ CODE 5
 H=50% HEAVY
 U="UT"
 P="FU"
 O="CL"
 N="LC"
 M="VM"
 L="RT"
 K="OM"
 F="MM"
 E="AS"
 D=Light (1.5 S.G.)
 C=30% Hvy. (2.0 S.G.)
 B=20% Hvy. (1.9 S.G.)
 A=10% Hvy. (1.8 S.G.)
 S=Std. (1.7 S.G.)

5= 3" BOLT IN BANJO W/ EPDM GASKET (10910)
 3= 3" BOLT IN FLANGED BANJO (10915)
 Z= 3" SS BOLT IN RHINO (10011)
 Y= 2" SS BOLT IN (10203)
 P= 2" Bulkhead w/ Anti-Vortex (12516)
 W=1/2" SPINWELD (10442)
 X=See Print
 V=1" Spinweld (10443)
 U=1-1/2" Spinweld (10242)
 T=1-1/4" Spinweld (10085)
 R=3/4" Spinweld (10239)
 Q=1/2" Ace Bulkhead
 (10058(item 10442(spinweld) 3gal specialty))
 O=3" Ftg. w/ Long Syphon Tube
 (12528 & 10489)
 N=No fitting
 M=2" Ftg. w/ Long Syphon Tube
 (10508 & 10488)
 L=2" Ftg. w/ Syphon Tube
 (10508 & 10511)
 K=3" S.S. Bulkhead (10487)
 J=3" ACE Bulkhead. (12528)
 I=2" S.S. Bulkhead (10490 or 10486)
 H=2" H.D. Bulkhead (10912)
 G=2" Ace Bulkhead (10508)
 F=1-1/2" Ace Bulkhead (10507)
 E=1-1/4" Ace Bulkhead (10918)
 D=1" Ace Bulkhead (10485)
 C=1" Poly Bulkhead (10503)
 B=3/4" Ace Bulkhead (10484)
 A=3/4" Poly Bulkhead (10501)
 S=Std.

1 = Hinged Lid Assy. (19502/19505)
 W = Optional Bolt On Top (OP)
 Z = 7" STEP VENT (12427)
 Y = 5" STEP VENT (12110)
 X = See Print
 V = 5" Non-vented (10523)w/ EPDM Gasket (11042)
 T = Tether
 S = Std.
 R = Standard 16" Precision Lid (19096)
 U = 7" Non-vented (12415)
 Q = 16" Hinged HYTEK(10516)
 P = Summers 16" Precision Lid (19074)
 O = 7" Vented (12414)
 N = No lid
 M = 8" Ring only (10520)
 L = 16" Non-vented (10751)
 K = 8" Non-vented (19166)
 J = Banjo 16" Lid (vented 10750)
 I = Banjo 10" Lid
 (vented 10021, non-vented 10080)
 H = 12" Non-vented (10526)
 G = 5" Non-Vented (10523)
 F = 22" Vented (10530)
 E = 16" Vented (10528)
 D = 12" Vented (10527)
 C = 8" Vented (10525)
 B = 5" Vented (10522)
 A = 2" Vented (10631)

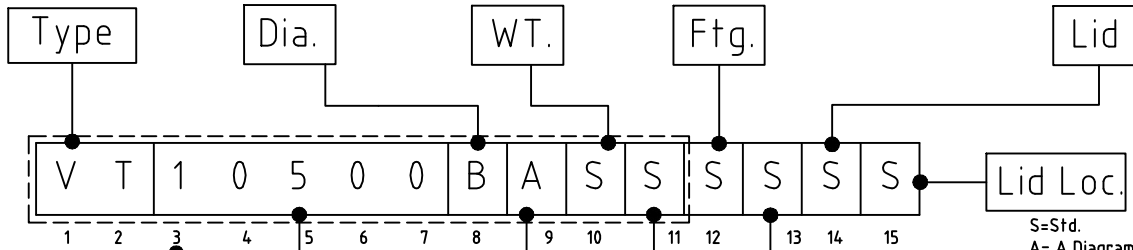

10500
 00025
 Etc.

X=FDA Dark Green
 W=White
 Y=Yellow
 C=JD Green
 D= Ritchie Blue
 E= Light Blue
 F= BlackXLPE
 G= ICM Dark Green
 H= FDA Black
 I= Dark Blue
 J= Black / White inside
 K= FDA Blue
 L= FDA Snyder Green
 M= White / Black inside
 N= NOL/Dark Green
 R= Spruce Green
 T= Desert Tan
 Q = Hagie Grey
 P = Natural XLPE
 U = KCI Green
 V = Case Gray
 O = Opaque White
 A = Silver Metallic Grey
 B = Black Re grind
 Z = Covert Green
 1 = Shale Green

S=Std.
 A= A Diagram
 B= B Diagram
 C= C Diagram
 D= D Diagram
 E= E Diagram
 L=Ship Loose
 N=No Ftg.
 M= Multiple - see print
 X=See Print

S=Std.
 B=Viton
 A=EPDM
 N=No gasket
 X=See Print
 C= Std. gasket and 3/4 A.V.
 D= EPDM gasket and 3/4 A.V.
 E= Viton gasket and 3/4 A.V.
 F= Std. gasket and 1-1/4 A.V.
 G= EPDM gasket and 1-1/4 A.V.
 H= Viton gasket and 1-1/4 A.V.

S=Std.
 A= A Diagram
 B= B Diagram
 N= No lid
 C= As centered as possible
 M=Multiple Lids
 X=See Print

SUMP / FD
 FD = Full Drain (IB/IN/CB)
 A = Sectional FS/FM Left
 B = Sectional FS/FM Right
 D = Deep Sump (HZ/HE)
 F = Flat No Sump (HZ/HE)



Den Hartog
INDUSTRIES, INC.

4010 Hospers Drive South
P.O. Box 425
Hospers IA 51238-0425
Ph: (800) 342-3408
Fax: (712) 752-8222

www.denhartogindustries.com