

© DEN HARTOG INDUSTRIES, INC.

Copyright. All information furnished within this document, electronic file or design correspondence is the property of Den Hartog Industries, Inc. and shall not be used, disclosed to others or copied without the expressed written consent of Den Hartog Industries, Inc.

PART NUMBER	DESCRIPTION	MATERIAL	SHOT WEIGHT	SHIPPING WEIGHT
AF1248-20	AIR FLOAT, 12X48X20	10548	20.00 LBS (9.07 KG)	21.00 LBS (9.53 KG)
FF1248-20	FOAM FLOAT, 12X48X20			27.00 LBS (12.25 KG)

1248-20

G

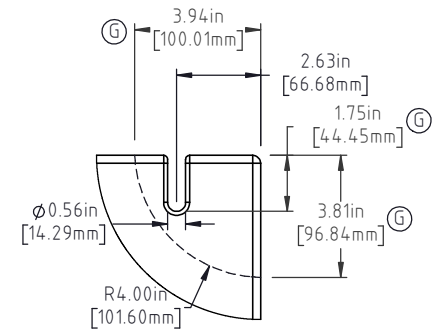
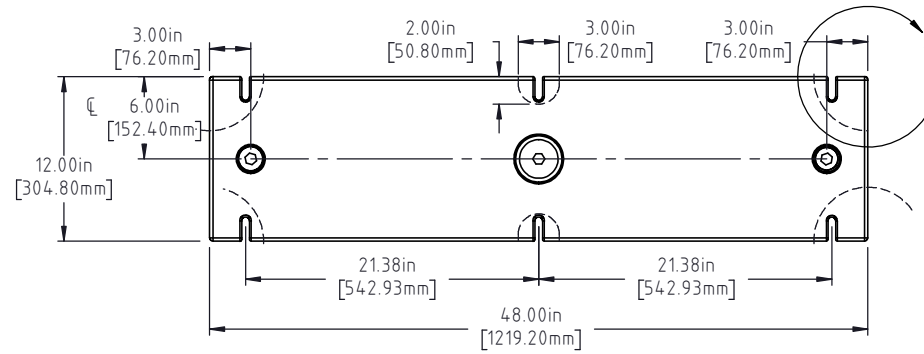

DETAIL A  
SCALE 1 : 6

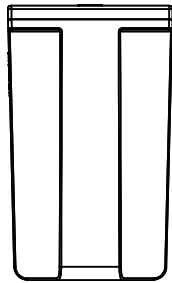

E

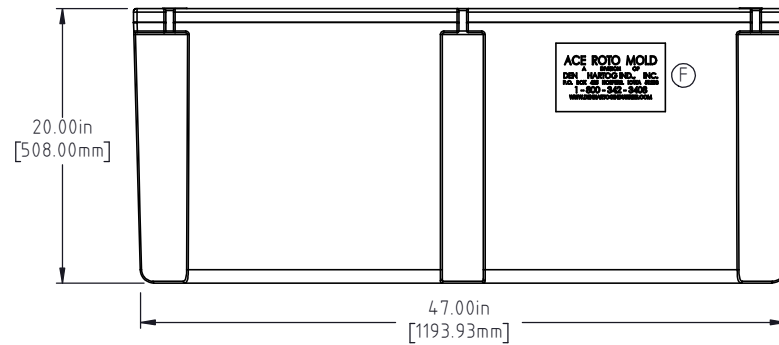

F

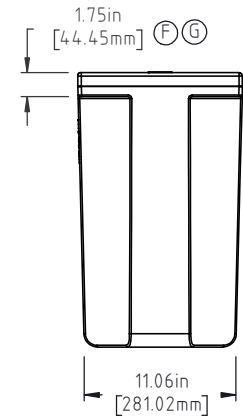

ⓓ ⓑ NOTE: BUOYANCY 359 LBS (162.84 KG)

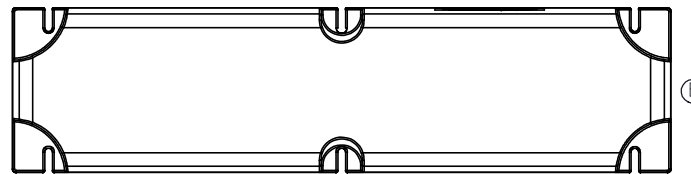

E

G	FLANGE AND CORNERS REVISED. 3.94 & 3.84 WAS 4.00, 1.75 WAS 1.63, 1.75 WAS 1.50.	ADH	1/12/2021	4081	DRAWN / DATE	POLYETHYLENE
F	TABLE ADDED. 1.50" WAS 1.75", ENGRAVING MOVED TO STANDARD LOCATION.	ADH	11/23/2020	4070	DHJ 4/19/1994	
E	BOTTOM AND SIDE VIEWS ADDED TO PRINT	ADH	12/4/2014	2971	APPR. / DATE	
REV.	DESCRIPTION	BY	DATE	CCN	ADH 11/2/2007	
ALL DIMENSIONS ARE IN DECIMAL INCHES TOLERANCES UNLESS OTHERWISE SPECIFIED		THIRD ANGLE PROJECTION ANSI 14.5M			SHOT WEIGHT: SEE TABLE.	NOTES: ⓐ ⓓ 0.150 (3.81mm) NOM. WALL
POLYETHYLENE		METAL DECIMAL ± .125" FRACTION ± 1/4" ANGLE ± 1°			SHIPPING WEIGHT: SEE TABLE.	
±1% @ 68°F		FINISH:				



**Den Hartog**  
INDUSTRIES, INC.

Ace Roto-Mold Injection Molding Blow Molding Sowjoy

4010 HOSPERS DRIVE S. BOX 425, HOSPERS, IOWA 51238-0425

DESCRIPTION	12 X 48 X 20 FLOAT	
SCALE	N.S.	PART NO. 1248-20
SHEET	1 OF 1	