

Copyright. All information furnished within this document, electronic file or design correspondence is the property of Den Hartog industries, Inc. and shall not be used, disclosed to others or copied without the expressed written consent of Den Hartog Industries, Inc.

DETAIL A
SCALE 1 : 3

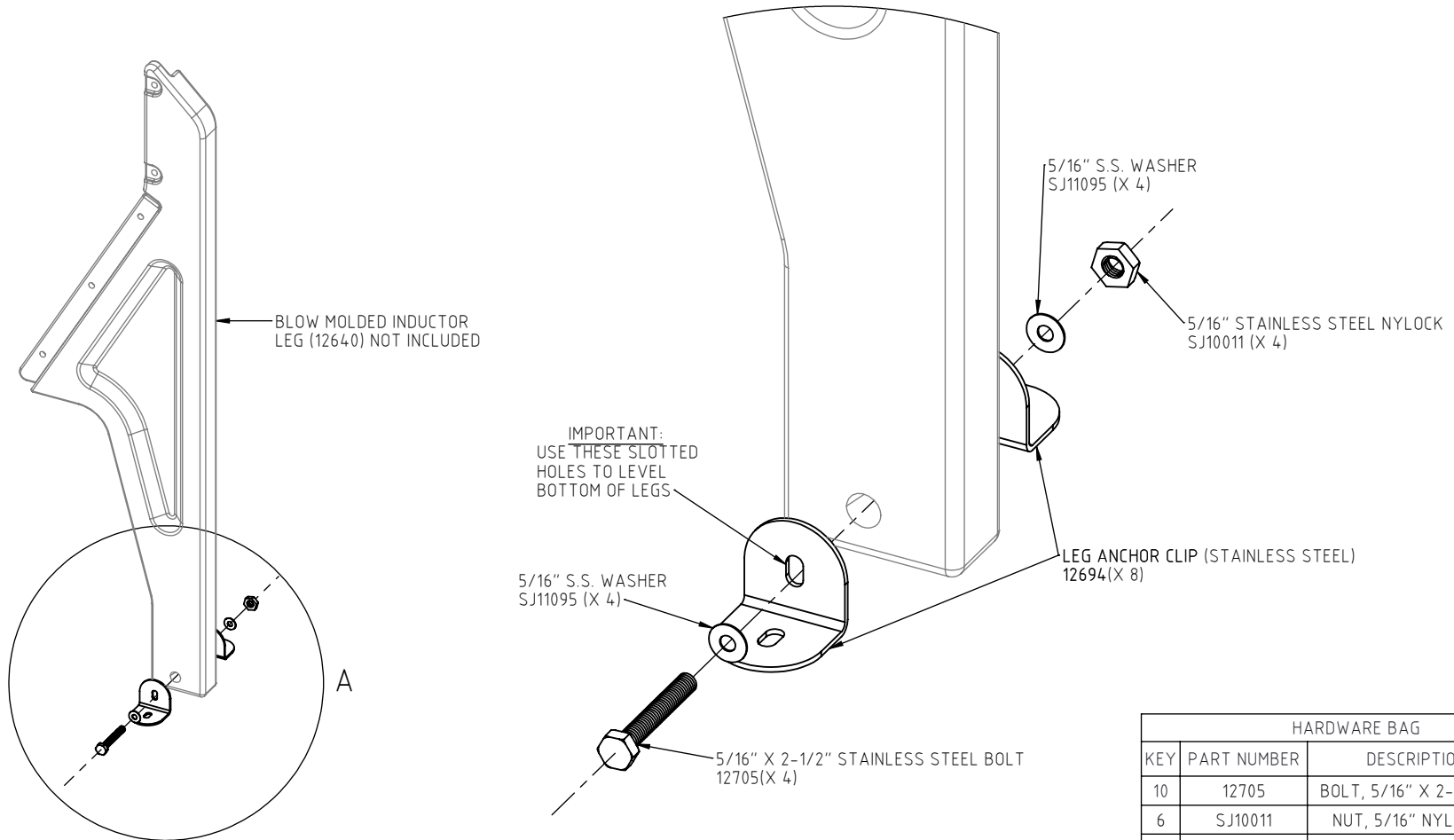

HARDWARE BAG			
KEY	PART NUMBER	DESCRIPTION	QTY.
10	12705	BOLT, 5/16" X 2-1/2" SS	4
6	SJ10011	NUT, 5/16" NYLOK SS	4
3	12694	INDUCTOR STAND ANCHOR	8
4	SJ11095	WASHER, 5/16" FLAT SS	8
5	12695	ASSY. INSTRUCTIONS	1

				DRAWN / DATE ADH 6/8/09	MATERIAL
				APPRD. / DATE REH 6/11/09	
REV	DESCRIPTION	BY / DATE	CCN	SHOT WEIGHT:	NOTES:
				SHIPPING WEIGHT:	
				FINISH:	
ALL DIMENSIONS ARE IN DECIMAL INCHES TOLERANCES UNLESS OTHERWISE SPECIFIED		THIRD ANGLE PROJECTION ANSI 14.5M			
POLYETHYLENE ±1% @ 68°F		METAL DECIMAL ± .125" FRACTION ± 1/4" ANGLE ± 1°			



Den Hartog
INDUSTRIES, INC.

Ace Roto-Mold Injection Molding Blow Molding Sowjoy

4010 HOSPERS DRIVE S. BOX 425, HOSPERS, IOWA 51238-0421

DESCRIPTION LEG ANCHOR KIT FOR 35 & 60 GALLON BLOW MOLDED INDUCTORS	
SCALE N.S.	PART NO. 12695