

© DEN HARTOG INDUSTRIES, INC.

Copyright. All information furnished within this document, electronic file or design correspondence is the property of Den Hartog industries, Inc. and shall not be used, disclosed to others or copied without the expressed written consent of Den Hartog Industries, Inc.

12929

KEY	PART NUMBER	DESCRIPTION	QTY.
1	12929-1	1.66 TUBE	1
2	12929-2	LOOP	1
3	12929-3	PAN	1
4	12929-4	SIDE PLATE	2
5	12929-5	SUPPORT ROD	2
6	12929-6	FORMED CHANNEL	1
7	12929-7	VERTICAL ROD	7
8	12929-8	BOLT PLATE	1
9	12929-9	WATER PIPE	1
10	12656	VALVE, AQUAMASTER	1
11	12931	BOLT, U 1 5/8"	1
12	12554	WASHER, 1/4" SS	2
13	10278	NUT, 1/4" NYLOK SS	2

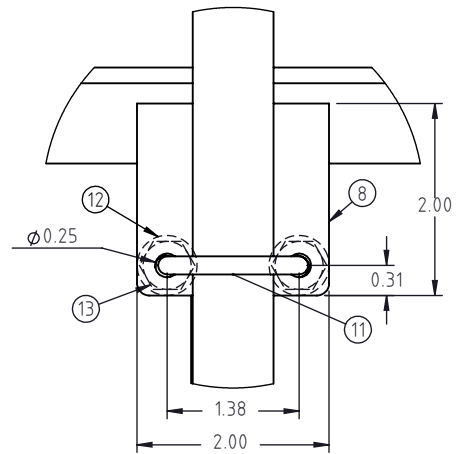
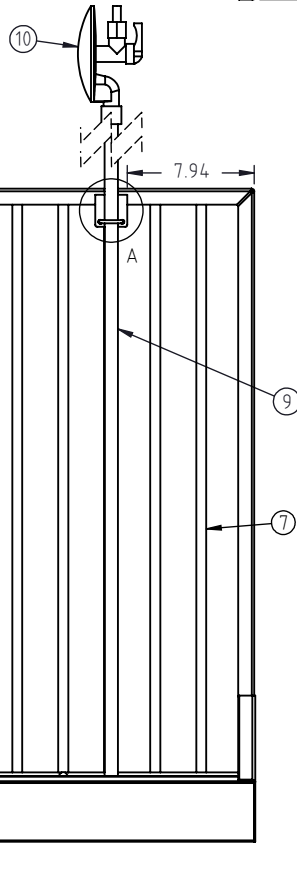
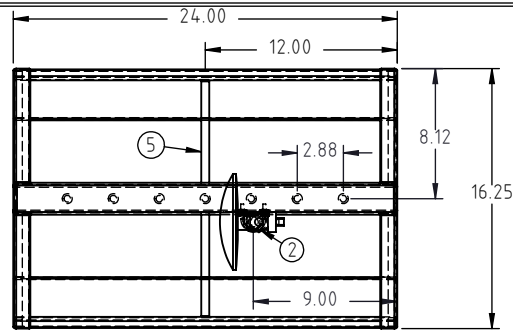

DETAIL A
SCALE 1 : 2

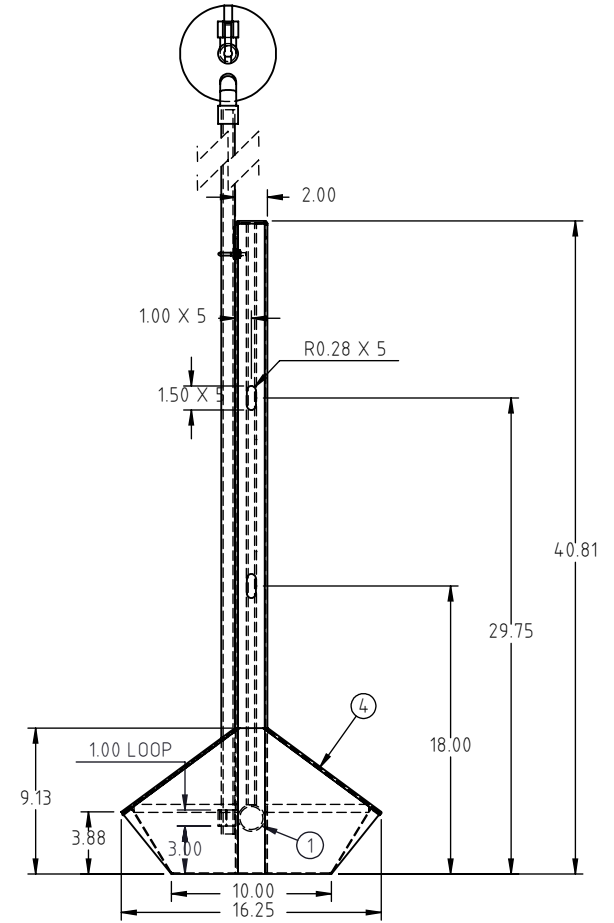

REV	DESCRIPTION	BY / DATE	CCN	DRAWN / DATE ADH 1/19/09	MATERIAL
				APPRO. / DATE KGJ 8/2/10	
ALL DIMENSIONS ARE IN DECIMAL INCHES TOLERANCES UNLESS OTHERWISE SPECIFIED		THIRD ANGLE PROJECTION ANSI 14.5M		SHOT WEIGHT:	NOTES:
POLYETHYLENE		METAL DECIMAL ± .125" FRACTION ± 1/4" ANGLE ± 1°		SHIPPING WEIGHT:	
±1% @ 68°F				FINISH:	



Den Hartog
INDUSTRIES, INC.

Ace Roto-Mold Injection Molding Blow Molding Sowjoy

4010 HOSPERS DRIVE S. BOX 425, HOSPERS, IOWA 51238-0421

DESCRIPTION 24" SOWJOY WATERER	
SCALE N.S.	PART NO. 12929