

Copyright. All information furnished within this document, electronic file or design correspondence is the property of Den Hartog Industries, Inc. and shall not be used, disclosed to others or copied without the expressed written consent of Den Hartog Industries, Inc.

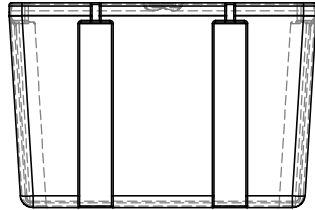

D

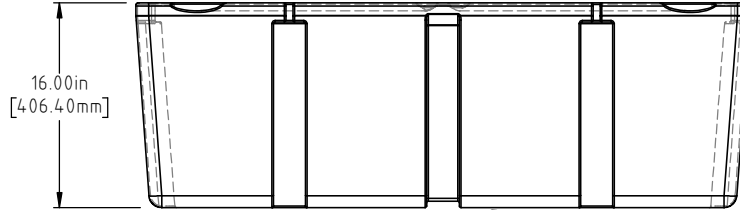
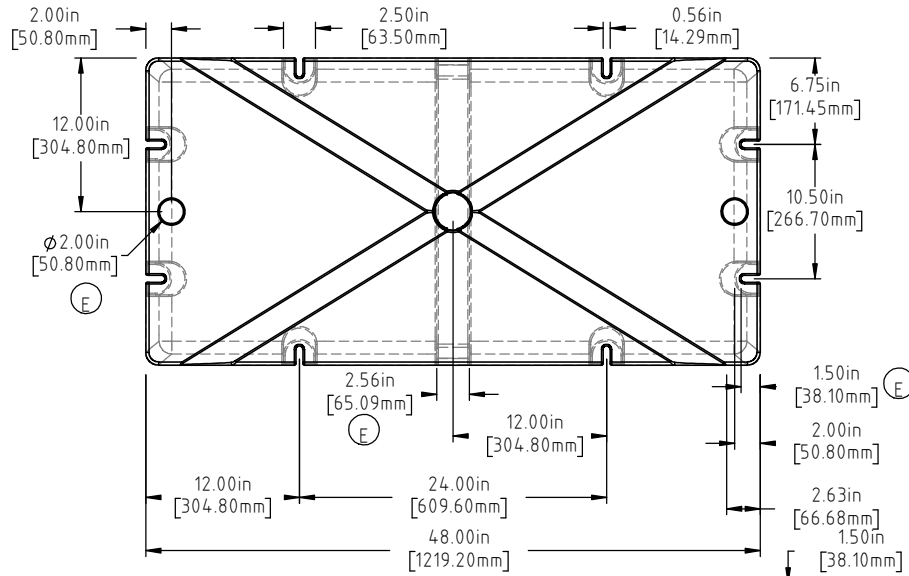

16.00in [406.40mm]

45.78in [1162.92mm]

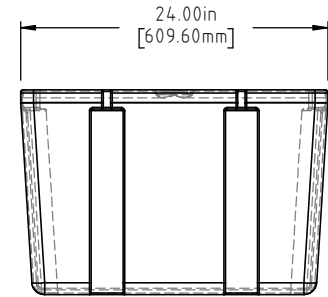

22.13in [561.98mm]

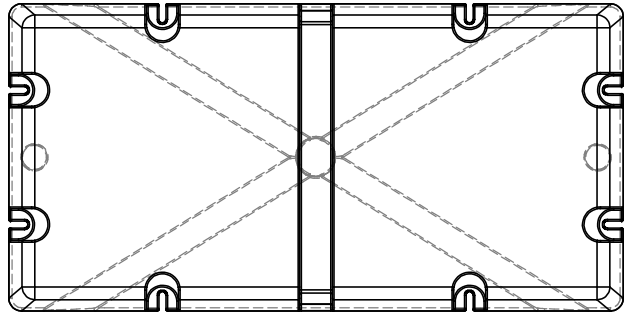

D

E	DIMENSIONS UPDATED. SPINWELD DETAILS ADDED.	ADH 11/16/16	3321
D	BOTTOM AND SIDE VIEWS ADDED TO PRINT	ADH 12/4/14	2971
C	39 LBS WAS 37 LBS, 581 LBS WAS 585 LBS	ADH 6/20/12	2420
B	METRIC DIMENSIONS ADDED	ADH 6/12/08	1685
A	ADD BUOYANCY NOTE	GWC 1/8/07	
A	CHANGE WEIGHTS AF WAS 25 FF WAS 40	GWC 1/8/07	
1	CHANGE WEIGHTS	11/16/94	
REV	DESCRIPTION	BY / DATE	CCN

DRAWN / DATE	MATERIAL
DEAN 10/12/93	POLYETHYLENE
APPRD. / DATE	
ADH 11/5/07	

SHOT WEIGHT:	NOTES: (A)(C)
27 LBS.(12.25 KG.)	1.) AF 27 LBS.(12.25 KG.)
SHIPPING WEIGHT:	2.) FF 39 LBS.(17.69KG.)
SEE NOTES	3.) 0.150 IN (3.81 mm) NOM. WALL
FINISH:	

(A)(L) NOTE: BUOYANCY IS 581 LBS.(263.54 KG)



Den Hartog
INDUSTRIES, INC.

Ace Roto-Mold Injection Molding Blow Molding Sowjoy
4010 HOSPERS DRIVE S. BOX 425, HOSPERS, IOWA 51238-0425

ALL DIMENSIONS ARE IN DECIMAL INCHES
TOLERANCES UNLESS OTHERWISE SPECIFIED

POLYETHYLENE	METAL DECIMAL ± .125" FRACTION ± 1/4" ANGLE ± 1°
±1% @ 68°F	

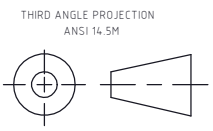

DESCRIPTION	24 X 48 X 16 FLOAT
SCALE	N.S.
PART NO.	2448-16