

Copyright. All information furnished within this document, electronic file or design correspondence is the property of Den Hartog Industries, Inc. and shall not be used, disclosed to others or copied without the expressed written consent of Den Hartog Industries, Inc.

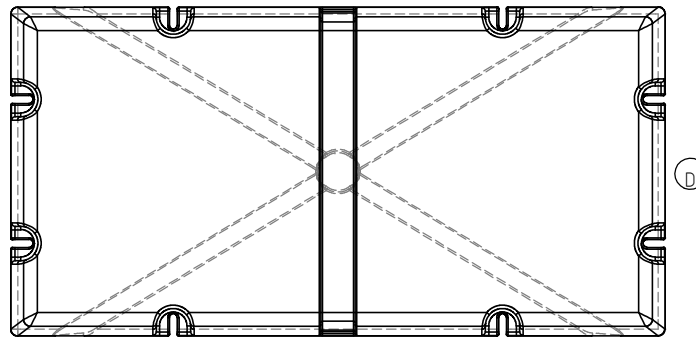
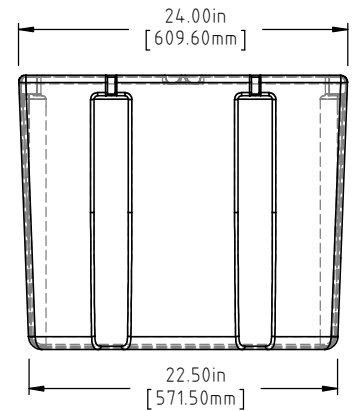
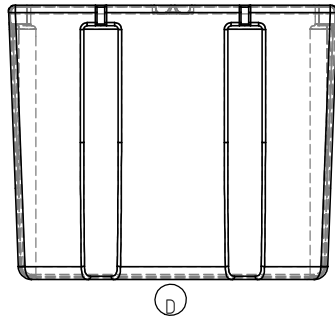
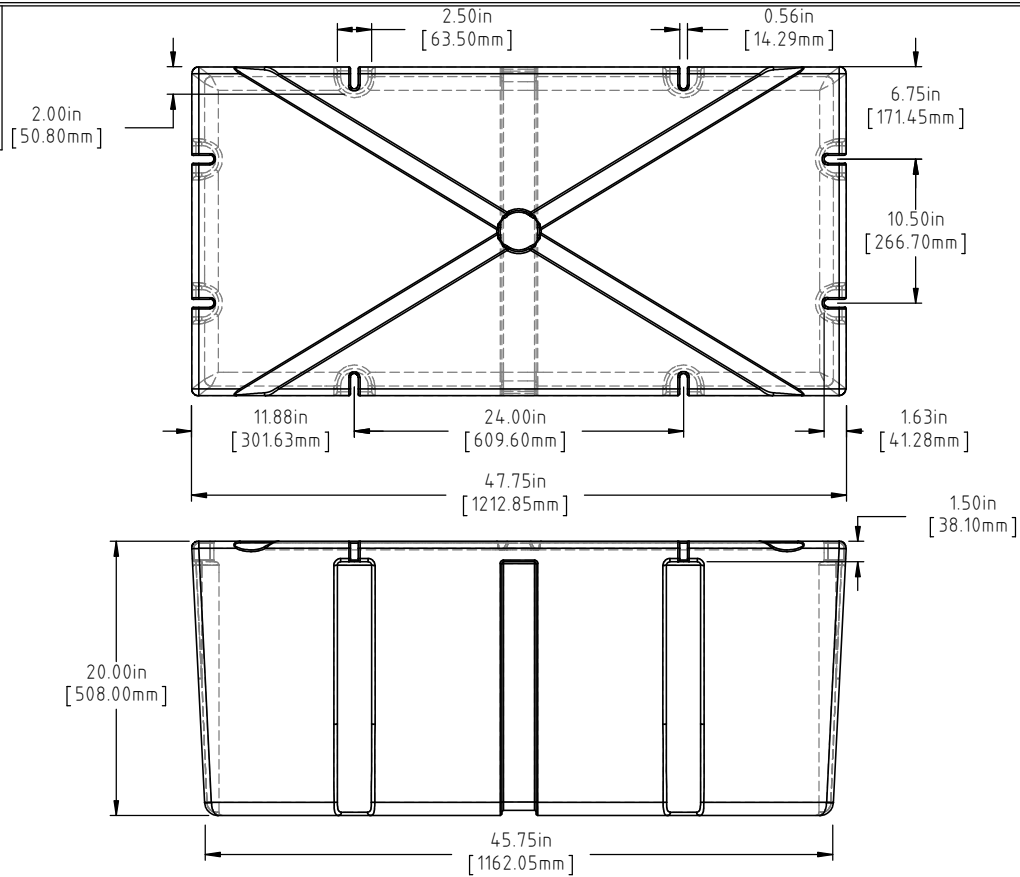

D	BOTTOM AND SIDE VIEWS ADDED TO PRINT	ADH 12/4/14	2971
C	44 LBS WAS 42 LBS, 729 LBS WAS 730 LBS	ADH 6/20/12	2420
B	METRIC DIMENSIONS ADDED	ADH 6/12/08	1685
A	ADD BUOYANCY NOTE	GWC 1/8/07	
A	CHANGE WEIGHTS AF WAS 28 FF WAS 48	GWC 1/8/07	
1	CHANGE WEIGHTS	11/16/94	
REV	DESCRIPTION	BY / DATE	CCN

DRAWN / DATE DEAN 10/13/93	MATERIAL POLYETHYLENE
APPRD. / DATE ADH 11/5/07	
SHOT WEIGHT: 30 LBS. (13.61 KG.)	NOTES: (A) (C) 1.) AF 30 LBS. (13.61 KG.) 2.) FF 4.4 LBS. (19.96 KG.) 3.) 0.150 IN (3.81 mm) NOM. WALL
SHIPPING WEIGHT: SEE NOTES	
FINISH:	

(A) (C)
NOTE: BUOYANCY IS 729 LBS. (330.67 KG)



Den Hartog
INDUSTRIES, INC.

Ace Roto-Mold Injection Molding Blow Molding Sowjoy

4010 HOSPERS DRIVE S. BOX 425, HOSPERS, IOWA 51238-0425

DESCRIPTION	24 X 48 X 20 FLOAT
SCALE	N.S.
PART NO.	2448-20

ALL DIMENSIONS ARE IN DECIMAL INCHES
TOLERANCES UNLESS OTHERWISE SPECIFIED

POLYETHYLENE	METAL DECIMAL ± .125" FRACTION ± 1/4" ANGLE ± 1°
±1% @ 68°F	

