

Copyright. All information furnished within this document, electronic file or design correspondence is the property of Den Hartog industries, Inc. and shall not be used, disclosed to others or copied without the expressed written consent of Den Hartog Industries, Inc.

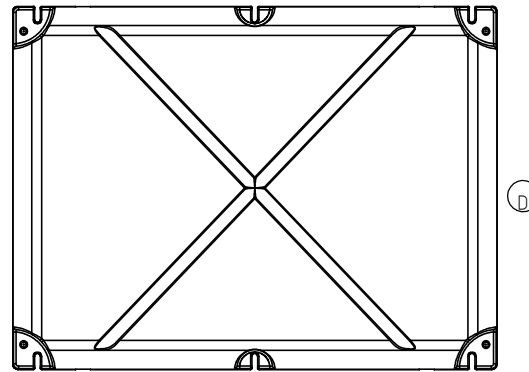
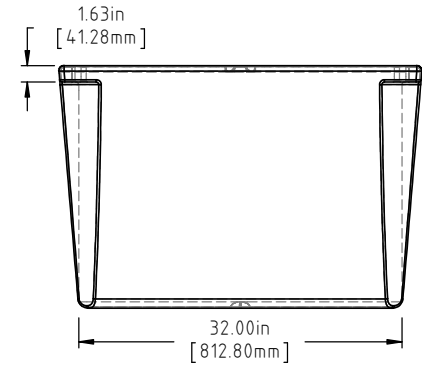
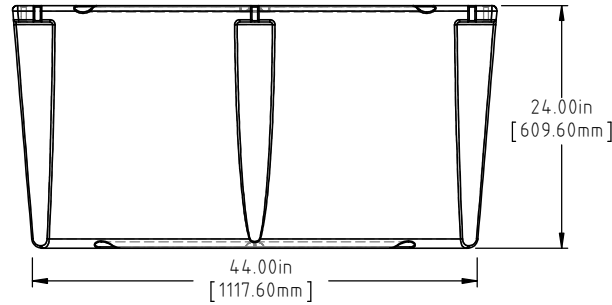
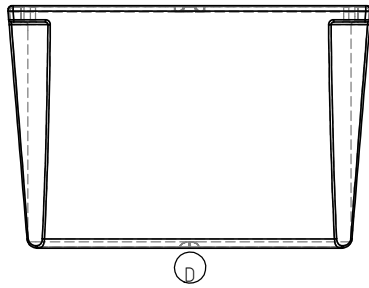
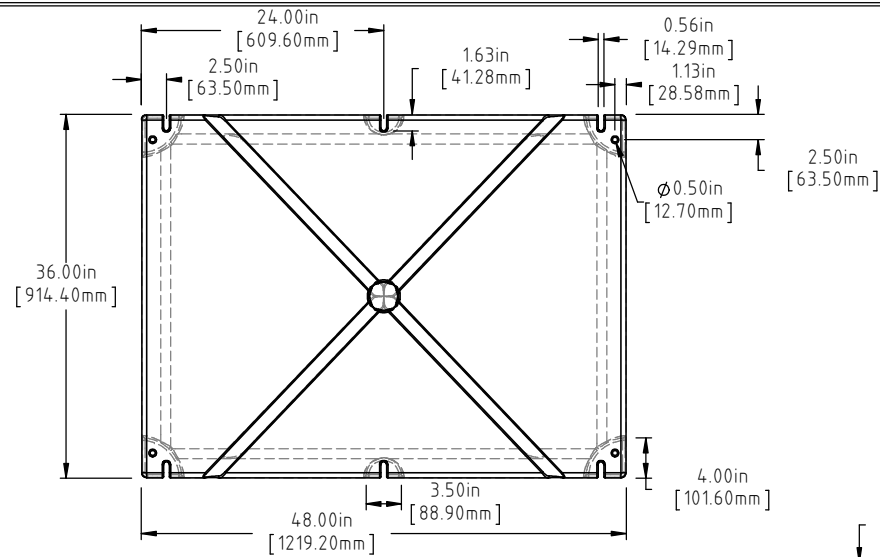

(A)(C)
NOTE: BUOYANCY IS 1280 LBS.(580.60 KG)

D	BOTTOM AND SIDE VIEWS ADDED TO PRINT	ADH 12/4/14	2971
C	66 LBS WAS 64 LBS, 1280 LBS WAS 1270 LBS	ADH 6/21/12	2420
B	METRIC DIMENSIONS ADDED	ADH 6/16/08	1685
A	ADD BUOYANCY NOTE	GWC 1/8/07	
A	CHANGE WEIGHTS FF WAS 74	GWC 1/8/07	
REV	DESCRIPTION	BY / DATE	CCN

DRAWN / DATE DHJ 3/10/98	MATERIAL POLYETHYLENE
APPROD. / DATE ADH 6/17/08	



Den Hartog
INDUSTRIES, INC.

Ace Roto-Mold Injection Molding Blow Molding Sowjoy

4010 HOSPERS DRIVE S. BOX 425, HOSPERS, IOWA 51238-0425

ALL DIMENSIONS ARE IN DECIMAL INCHES
TOLERANCES UNLESS OTHERWISE SPECIFIED
POLYETHYLENE
±1% @ 68°F

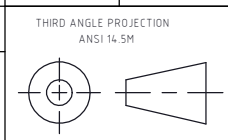

SHOT WEIGHT:
42 LBS.(19.05 KG.)
SHIPPING WEIGHT:
SEE NOTES
FINISH:

NOTES: (A)(C)
1.) AF 42 LBS.(19.05 KG.)
2.) FF 66 LBS.(29.94 KG.)
3.) 0.150 IN (3.81 mm) NOM. WALL

DESCRIPTION 36 X 48 X 24 FLOAT	SCALE N.S.	PART NO. 3648-24
-----------------------------------	---------------	---------------------