

© DEN HARTOG INDUSTRIES, INC.

Copyright. All information furnished within this document, electronic file or design correspondence is the property of Den Hartog Industries, Inc. and shall not be used, disclosed to others or copied without the expressed written consent of Den Hartog Industries, Inc.

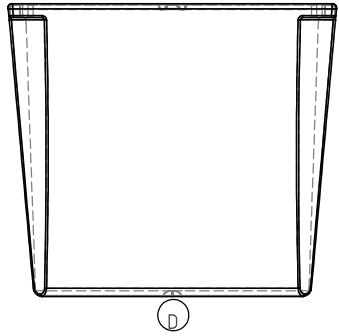
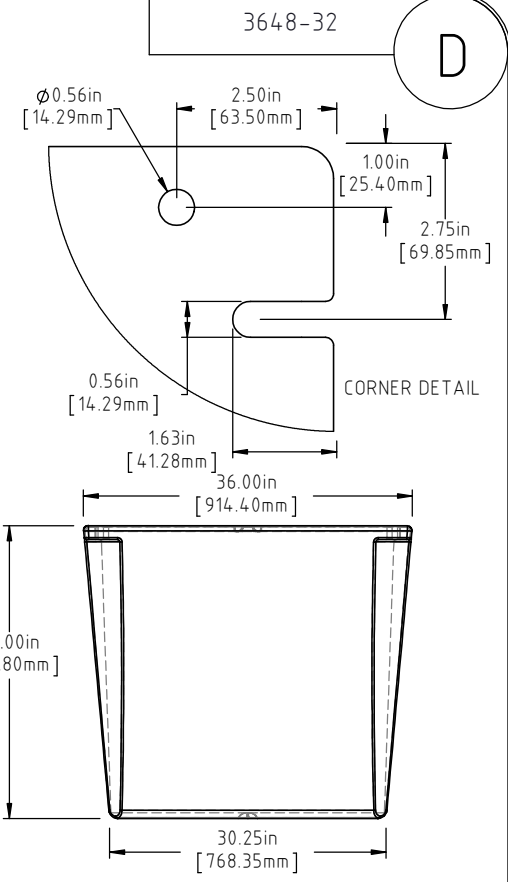
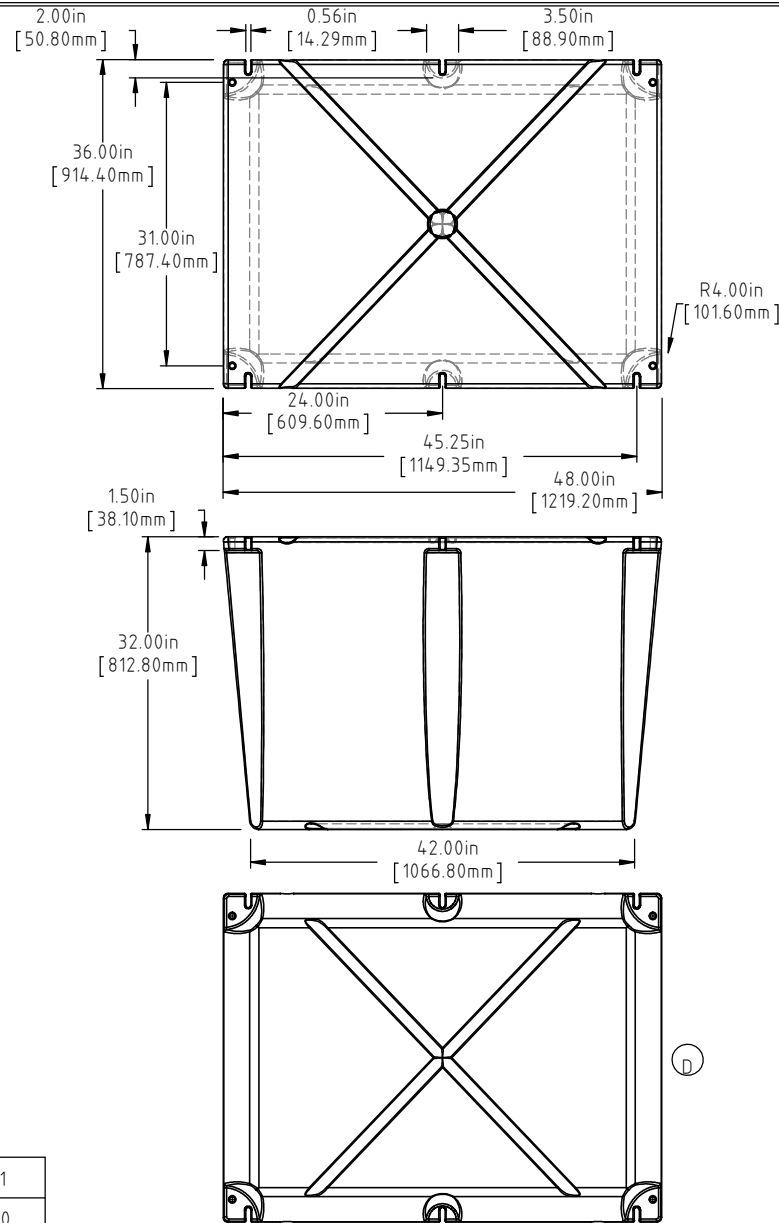

(A)(C)  
NOTE: BUOYANCY IS 1644 LBS.(745.71 KG)

D	BOTTOM AND SIDE VIEWS ADDED TO PRINT	ADH 12/4/14	2971
C	82 LBS WAS 88 LBS, 1644 LBS WAS 1609 LBS	ADH 6/21/12	2420
B	METRIC DIMENSIONS ADDED	ADH 6/17/08	1685
A	ADD BUOYANCY NOTE	GWC 1/8/07	
A	CHANGE WEIGHTS AF WAS 53 FF WAS 80	GWC 1/8/07	
REV	DESCRIPTION	BY / DATE	CCN
ALL DIMENSIONS ARE IN DECIMAL INCHES TOLERANCES UNLESS OTHERWISE SPECIFIED		THIRD ANGLE PROJECTION ANSI 14.5M	
POLYETHYLENE		METAL DECIMAL ± .125" FRACTION ± 1/4" ANGLE ± 1°	
±1% @ 68°F			

DRAWN / DATE REH 1/5/01	MATERIAL POLYETHYLENE
APPRD. / DATE ADH 11/5/07	
SHOT WEIGHT: 52 LBS.(23.59 KG.)	NOTES: (A)(C) 1.) AF 52 LBS.(23.59 KG.) 2.) FF 82 LBS.(37.19 KG.) 3.) 0.175in(4.45mm) NOM. WALL
SHIPPING WEIGHT: SEE NOTES	
FINISH:	

**Den Hartog**  
INDUSTRIES, INC.

Ace Roto-Mold Injection Molding Blow Molding Sowjoy

4010 HOSPERS DRIVE S. BOX 425, HOSPERS, IOWA 51238-0425

DESCRIPTION	36 X 48 X 32 FLOAT	
SCALE	N.S.	PART NO. 3648-32