

© DEN HARTOG INDUSTRIES, INC.

Copyright. All information furnished within this document, electronic file or design correspondence is the property of Den Hartog industries, Inc. and shall not be used, disclosed to others or copied without the expressed written consent of Den Hartog Industries, Inc.

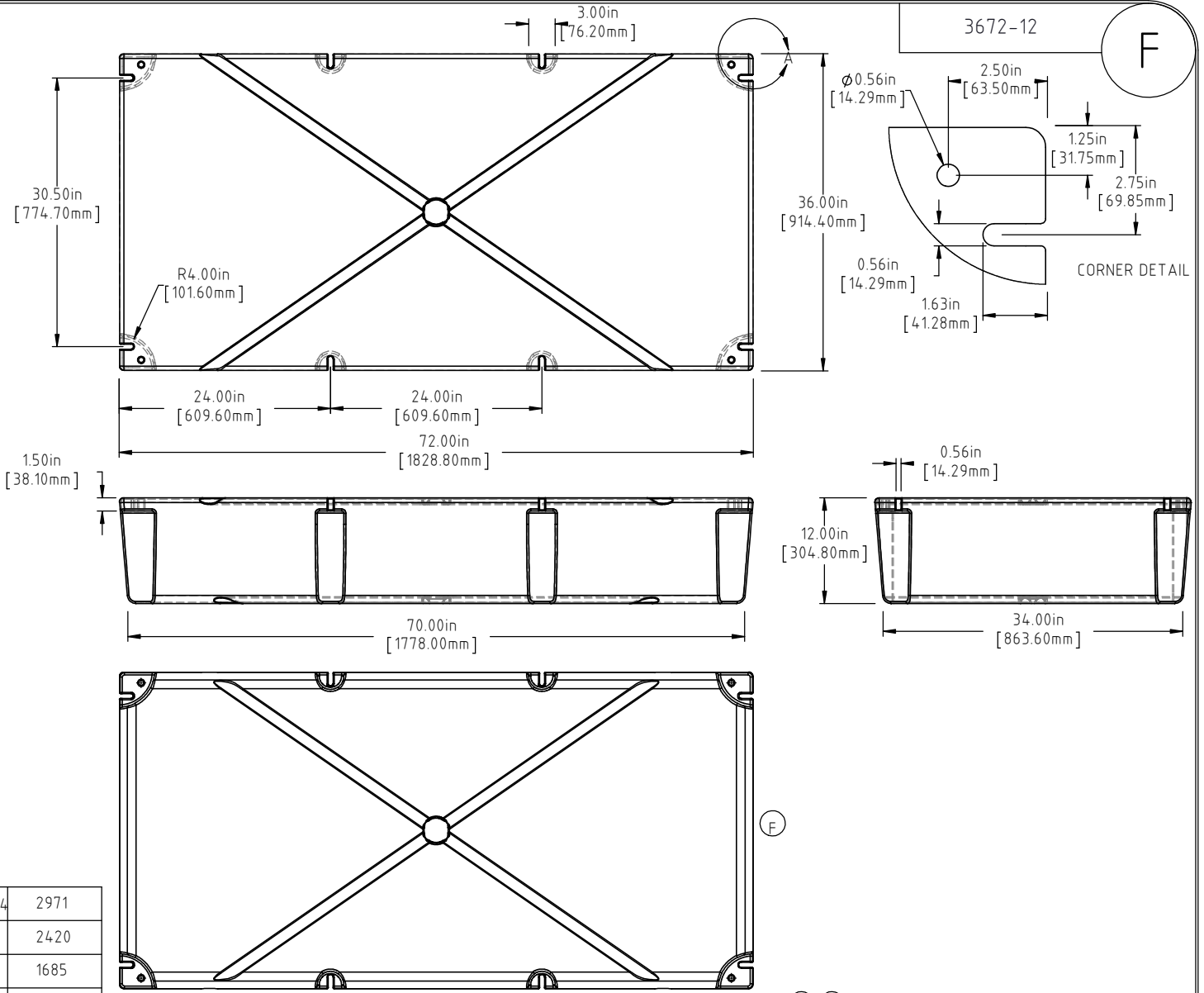

F	BOTTOM/SIDE VIEWS ADDED TO PRINT.	ADH 12/4/14	2971
E	62 LBS WAS 60 LBS, 999 LBS WAS 980 LBS	ADH 6/22/12	2420
D	METRIC DIMENSIONS ADDED	ADH 6/17/08	1685
C	ADD BUOYANCY NOTE	GWC 1/9/07	
C	CHANGE WEIGHT FF WAS 68	GWC 1/9/07	
B	NEW DIM	1/4/95	
A	CHANGE WEIGHTS	1/4/95	
REV	DESCRIPTION	BY / DATE	CCN

DRAWN / DATE DEAN 10/19/93	MATERIAL POLYETHYLENE
APPRO. / DATE ADH 11/5/07	
SHOT WEIGHT: 43 LBS.(19.50 KG.)	NOTES: (C) (E) 1.) AF 43 LBS.(19.50 KG.) 2.) FF 62 LBS.(28.12 KG.) 3.) 0.150in (3.81mm) NOM. WALL
SHIPPING WEIGHT: SEE NOTES	
FINISH:	



**Den Hartog**  
INDUSTRIES, INC.

Ace Roto-Mold Injection Molding Blow Molding Sowjoy  
4010 HOSPERS DRIVE S. BOX 425, HOSPERS, IOWA 51238-0425

DESCRIPTION	36 X 72 X 12 FLOAT
SCALE	N.S.
PART NO.	3672-12

ALL DIMENSIONS ARE IN DECIMAL INCHES  
TOLERANCES UNLESS OTHERWISE SPECIFIED  
POLYETHYLENE METAL  
DECIMAL ± .125"  
FRACTION ± 1/4"  
ANGLE ± 1°

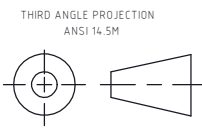

(C) (E) NOTE: BUOYANCY 999.00 LBS.(453.14 KG.)