

© DEN HARTOG INDUSTRIES, INC.

Copyright. All information furnished within this document, electronic file or design correspondence is the property of Den Hartog Industries, Inc. and shall not be used, disclosed to others or copied without the expressed written consent of Den Hartog Industries, Inc.

DWG NO. 4272-16

SH REV B

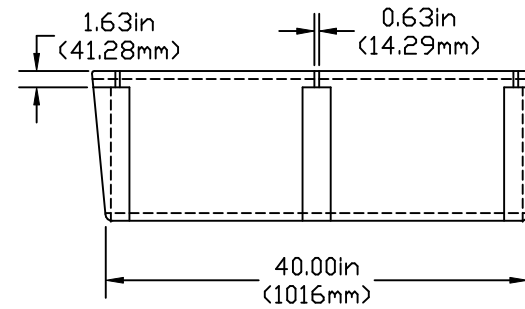
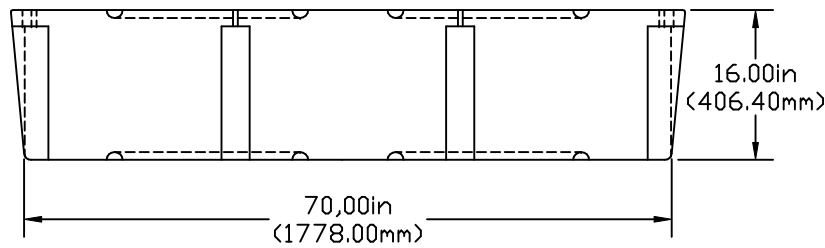
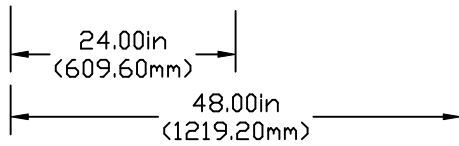
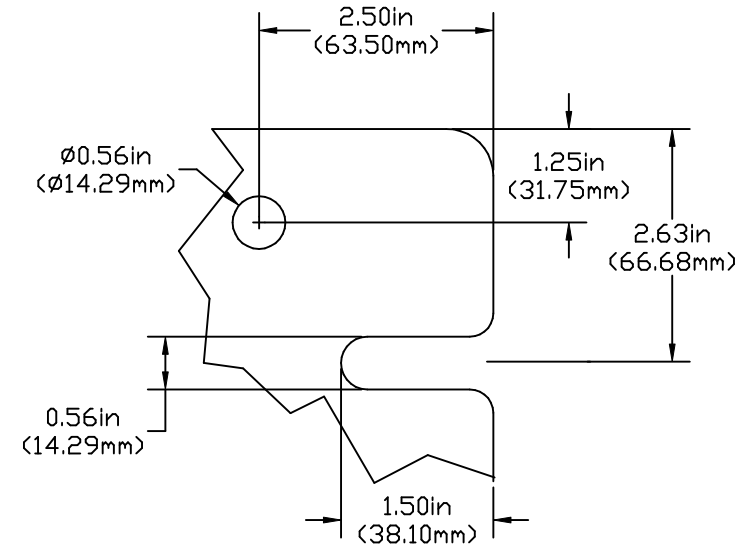
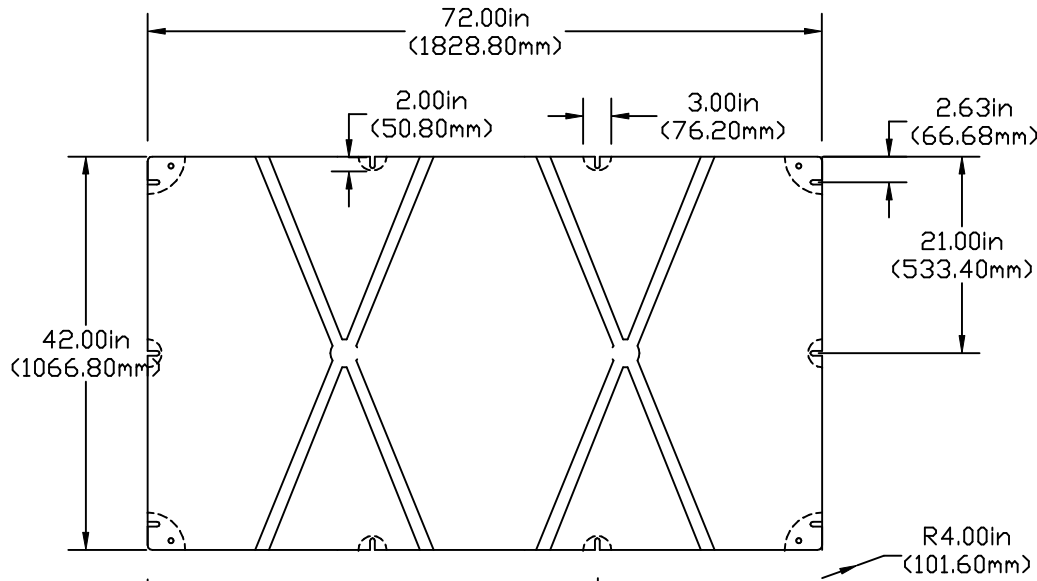

CORNER DETAIL

NOTE: BUOYANCY IS 1,536 LBS.(696.72 KG.)

B	METRIC DIMENSIONS ADDED CCN 1685	7-2-08	ADH	DRAWN	DATE	MATERIAL
A	ADD BUOYANCY NOTE	1-10-07	GWC	REH	9-9-98	POLYETHYLENE
A	CHANGE WEIGHT FF WAS 87	1-10-07	GWC	APPROVED	DATE	0.150in(3.81mm) NOM. WALL
REV	DESCRIPTION	DATE	APVD	ADH	11-5-07	
SCALE NONE			THIRD ANGLE PROJECTION			PART WEIGHT Ⓐ
UNITS DIMENSIONS ARE IN INCHES GENERAL TOLERANCES ±1% @ 68F° (20C°)						AF 55 LBS.(24.95 KG.) FF 81 LBS.(36.74 KG.)

<i>ACE ROTO-MOLD</i>	
PART NO.	4272-16
SIZE A	DWG NO. 4272-16
REV	B