

© DEN HARTOG INDUSTRIES, INC.

Copyright. All information furnished within this document, electronic file or design correspondence is the property of Den Hartog Industries, Inc. and shall not be used, disclosed to others or copied without the expressed written consent of Den Hartog Industries, Inc.

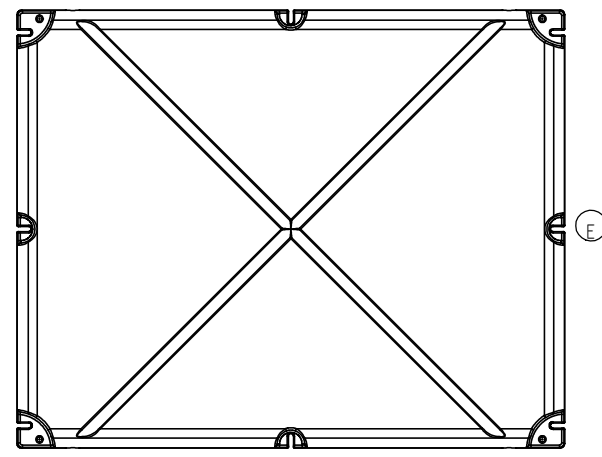
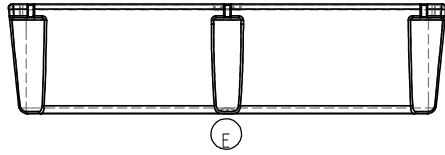
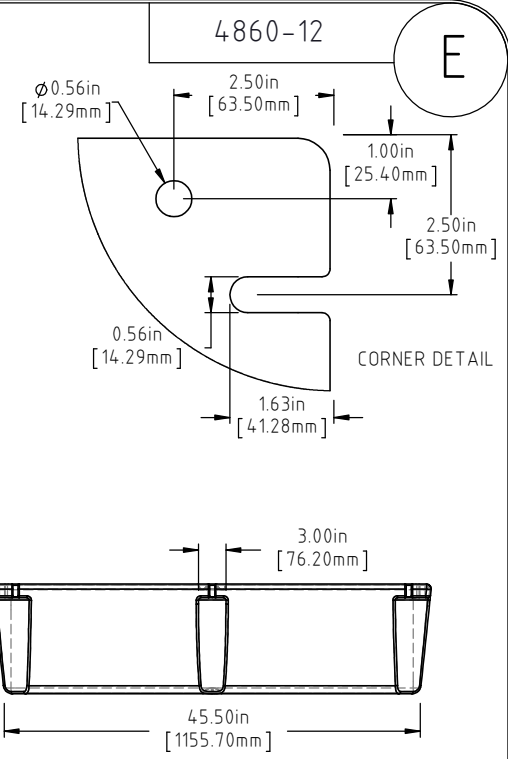
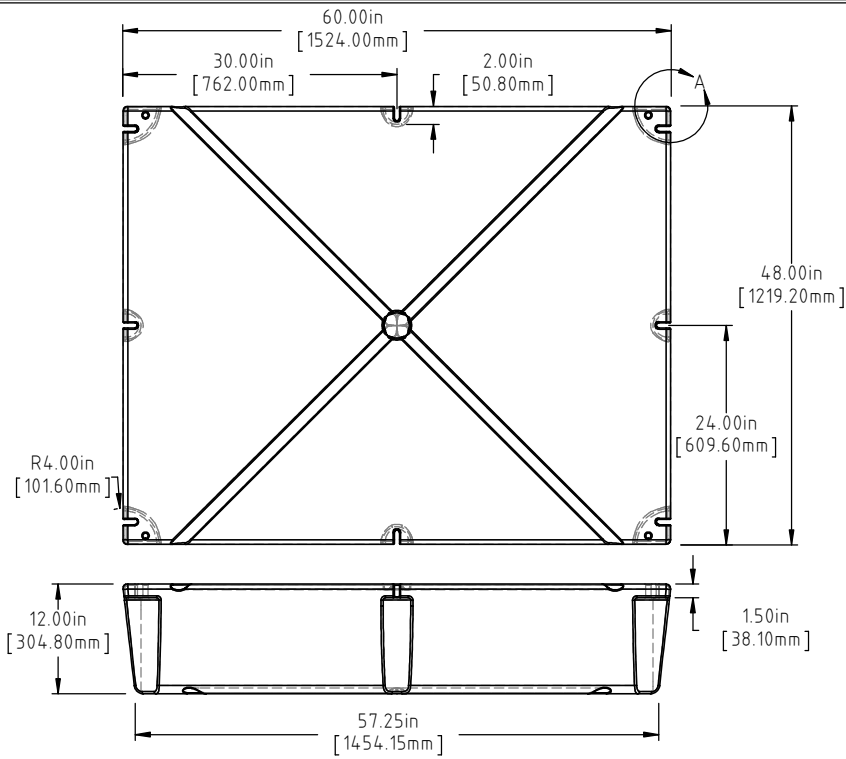

E	BOTTOM/SIDE VIEWS ADDED TO PRINT.	ADH 12/4/14	2971
D	73 LBS WAS 69 LBS, 1101 LBS WAS 1100 LBS	ADH 6/25/12	2420
C	METRIC DIMENSIONS ADDED	ADH 7/1/08	1685
B	ADD BUOYANCY NOTE	GWC 1/11/07	
B	CHANGE WEIGHTS FF WAS 70	GWC 1/11/07	
A	CHANGE SLOT ORIENTATION	DHJ 6/16/04	
REV	DESCRIPTION	BY / DATE	CCN

DRAWN / DATE	MATERIAL
DHJ 6/21/96	
APPRD. / DATE	POLYETHYLENE
ADH 11/5/07	

(B)(D) NOTE: BUOYANCY IS 1101 LBS.(499.41 KG)



Den Hartog
INDUSTRIES, INC.

Ace Roto-Mold Injection Molding Blow Molding Sowjoy
4010 HOSPERS DRIVE S. BOX 425, HOSPERS, IOWA 51238-0425

ALL DIMENSIONS ARE IN DECIMAL INCHES
TOLERANCES UNLESS OTHERWISE SPECIFIED
POLYETHYLENE
±1% @ 68°F

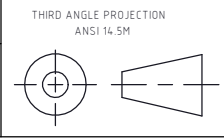

THIRD ANGLE PROJECTION
ANSI 14.5M
SHOT WEIGHT: 50 LBS. (22.68 KG.)
SHIPPING WEIGHT: SEE NOTES
FINISH:

NOTES: (B)(D)
1.) AF 50 LBS. (22.68 KG.)
2.) FF 73 LBS. (33.11 KG.)
3.) 0.150 IN (3.81 mm) NOM. WALL

DESCRIPTION	48 X 60 X 12 FLOAT	
SCALE	N.S.	PART NO. 4860-12