

© DEN HARTOG INDUSTRIES, INC.

Copyright. All information furnished within this document, electronic file or design correspondence is the property of Den Hartog Industries, Inc. and shall not be used, disclosed to others or copied without the expressed written consent of Den Hartog Industries, Inc.

4896-20

D

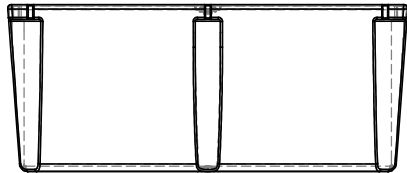
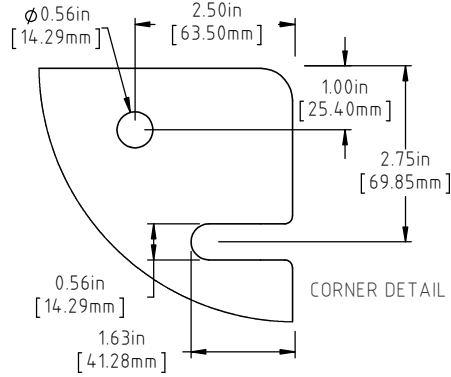

D

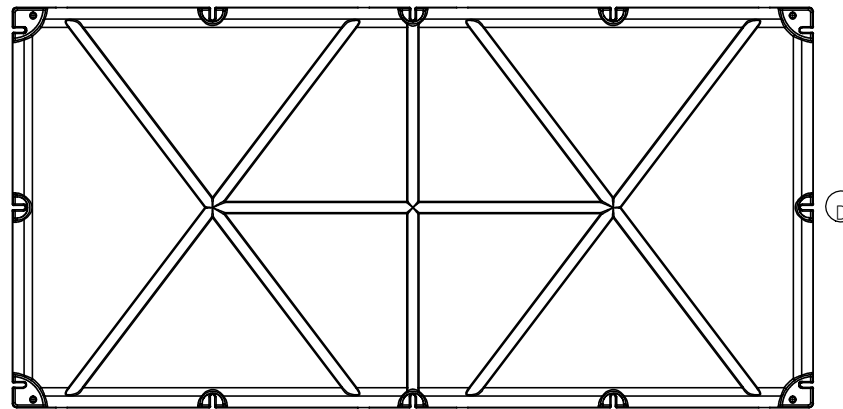
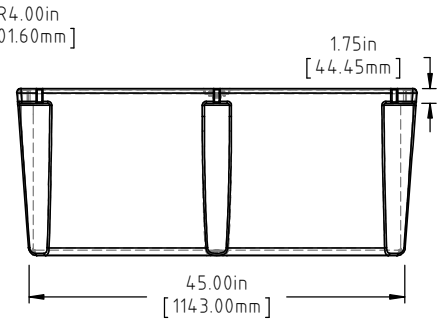
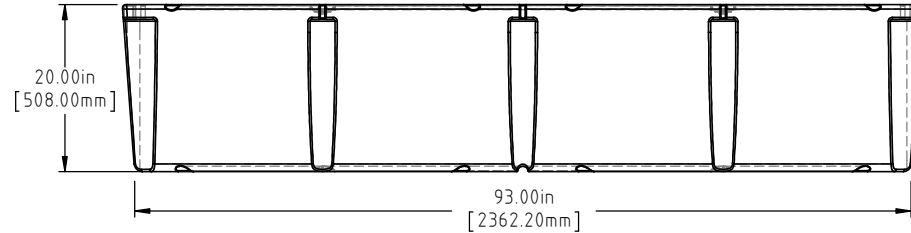
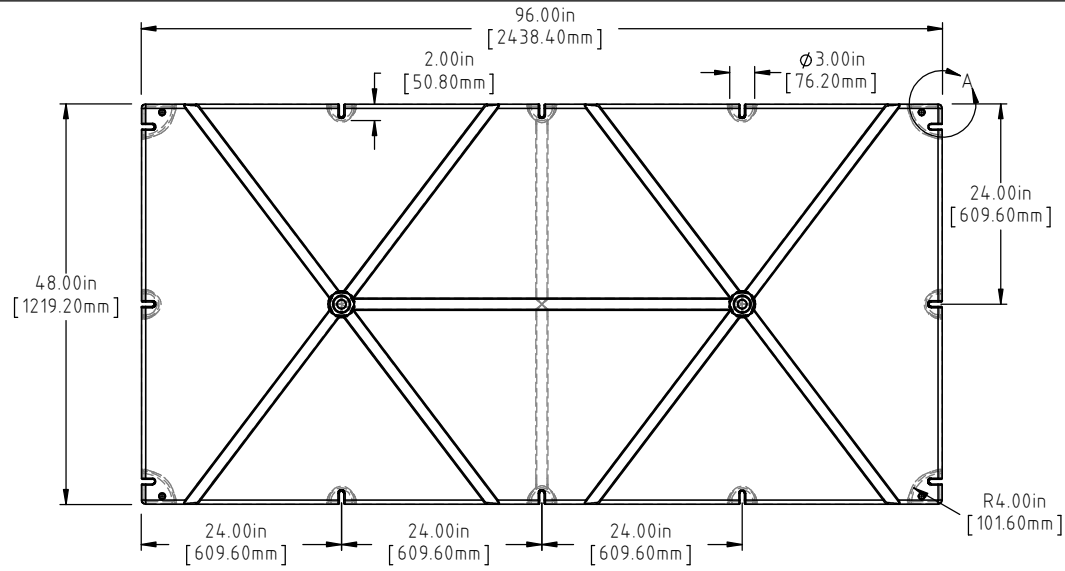

(A) (C)
NOTE: BUOYANCY 2996.00 LBS.(1358.96 KG.)

D	BOTTOM/SIDE VIEWS ADDED TO PRINT.	ADH 12/4/14	2971
C	145 LBS WAS 141 LBS, 2996 LBS WAS 2990 LBS	ADH 6/27/12	2420
B	METRIC DIMENSIONS ADDED	ADH 6/23/08	1685
A	ADD BUOYANCY NOTE	GWC 1/11/07	
A	CHANGE WEIGHT AF WAS 90 FF WAS 157	GWC 1/11/07	
1	CHANGE WEIGHT	11/17/94	
REV	DESCRIPTION	BY / DATE	CCN

DRAWN / DATE DEAN 10/19/93	MATERIAL POLYETHYLENE
APPRD. / DATE ADH 11/6/07	

ALL DIMENSIONS ARE IN DECIMAL INCHES
TOLERANCES UNLESS OTHERWISE SPECIFIED
POLYETHYLENE METAL
DECIMAL ± .125"
FRACTION ± 1/4"
ANGLE ± 1°
±1% @ 68°F

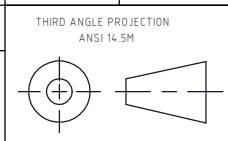

SHOT WEIGHT:
91 LBS.(41.28 KG.)
SHIPPING WEIGHT:
SEE NOTES
FINISH:

NOTES: (A) (C)
1.) AF 91 LBS.(41.28 KG.)
2.) FF 145 LBS.(65.77 KG)
3.) 0.150in(3.81mm) NOM. WALL

Den Hartog

INDUSTRIES, INC.

Ace Roto-Mold Injection Molding Blow Molding Sowjoy

4010 HOSPERS DRIVE S. BOX 425, HOSPERS, IOWA 51238-0425

DESCRIPTION	48 X 96 X 20 FLOAT	
SCALE	N.S.	PART NO. 4896-20