

Copyright. All information furnished within this document, electronic file or design correspondence is the property of Den Hartog industries, Inc. and shall not be used, disclosed to others or copied without the expressed written consent of Den Hartog Industries, Inc.

ITEM NO.	PART NUMBER	DESCRIPTION	QTY.
1	CB042-45ST-1	LEG TUBE	4
2	CB042-45ST-2	SIDE SUPORT TUBE	4
3	CB042-45ST-3	ROD, 1/2"	4
4	CB042-45ST-4	BASE STRAP	2
5	CB042-45ST-5	BASE STRAP W/ HOLES	2
6	CB042-45ST-6	TANK SUPPORT STRAP	4
7	12686	PIPE PLUG, 1-1/2" BLACK	4
8	CB042-45ST-8	SIDE SUPPORT TUBE	4
9	RAR-12	ROLLED ANGLE, 12" PLAIN	1

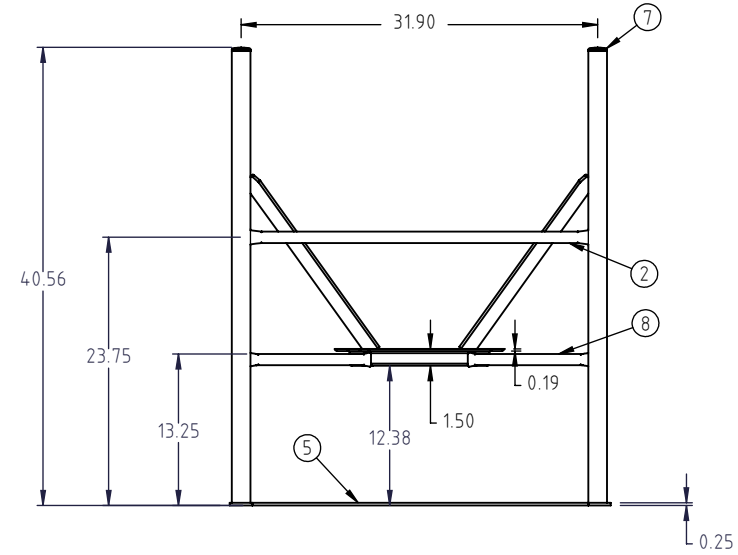
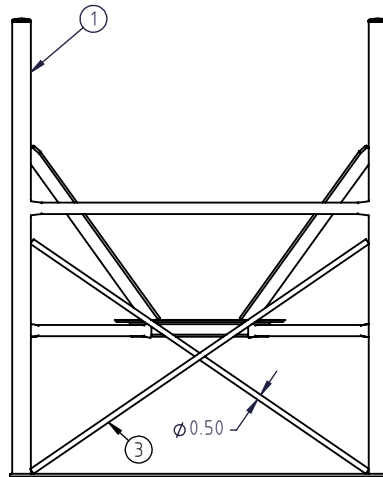
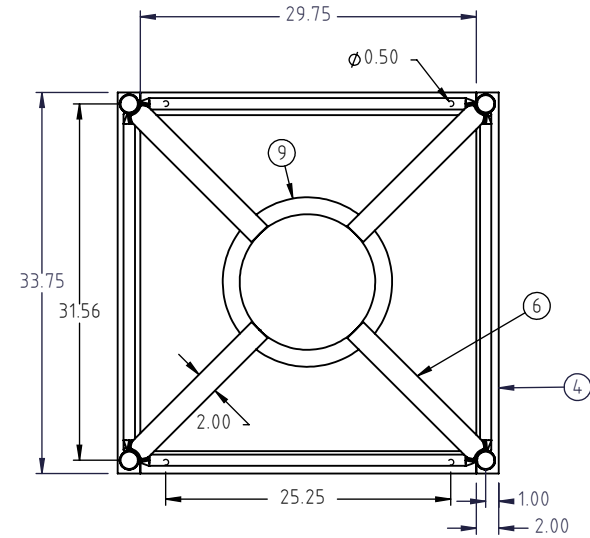

G

G	UPDATE TEMPLATE & DESCRIPTION	BES	7/25/2023	4447	DRAWN / DATE	MATERIAL :
F	12686 PLUG WAS CB042-45ST-7, 40.56 WAS 40.25	ADH	6/17/09	1888	ADH 6/15/2007	SEE COMPONENTS
E	SUPPORT STRAP DESIGN MODIFIED	ADH	2/6/09	1797	APPRD. / DATE	
REV.	DESCRIPTION	BY	DATE	CCN	REH 7/12/2007	
ALL DIMENSIONS ARE IN DECIMAL INCHES TOLERANCES UNLESS OTHERWISE SPECIFIED		THIRD ANGLE PROJECTION ANSI 14.5M		SHOT WEIGHT:		NOTES:
POLYETHYLENE		METAL		SHIPPING WEIGHT:		
±1% @ 68°F		DECIMAL ± .125" FRACTION ± 1/4" ANGLE ± 1°		82.00 LBS		
				FINISH: Powder Coat		



Den Hartog
INDUSTRIES, INC.

Ace Roto-Mold • Injection Molding • Blow Molding • Sowjoy
4010 HOSPERS DRIVE S. BOX 425, HOSPERS, IOWA 51238-0425

DESCRIPTION		CB, STAND 42" DIA 45 DEG	
SCALE	N.S.	PART NO.	CB042-45ST
		SHEET	1 OF 1