

Copyright. All information furnished within this document, electronic file or design correspondence is the property of Den Hartog Industries, Inc. and shall not be used, disclosed to others or copied without the expressed written consent of Den Hartog Industries, Inc.

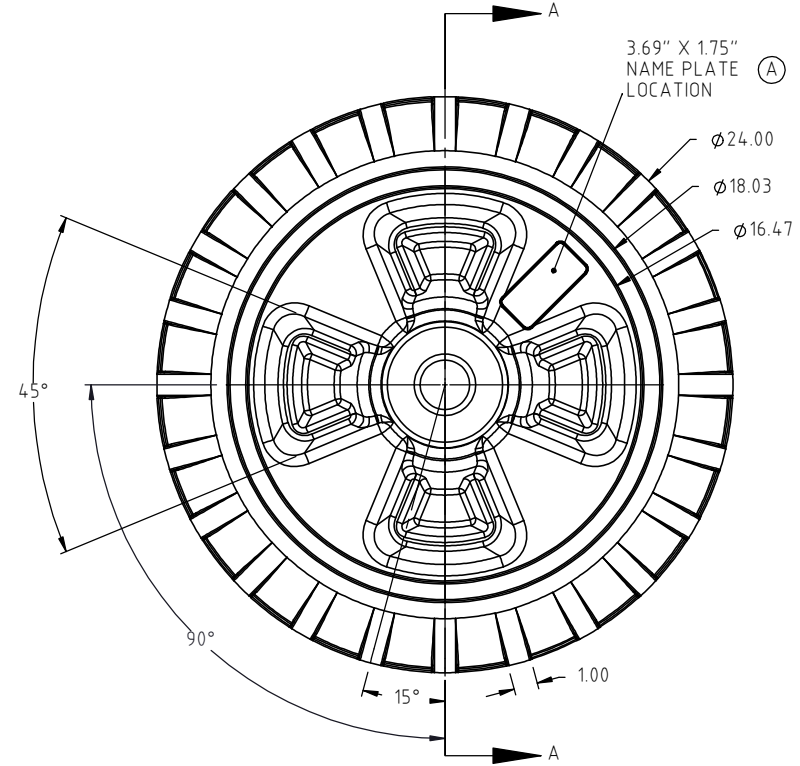

				DRAWN / DATE ADH 6/27/13	MATERIAL 80007 REGRIND W/ 80041 PIGMENT X 193 GM
A	NAME PLATE LOCATION ADDED TO PRINT	ADH 11/20/13	2742	APPRD. / DATE REH 7/16/13	
REV	DESCRIPTION	BY / DATE	CCN		
ALL DIMENSIONS ARE IN DECIMAL INCHES TOLERANCES UNLESS OTHERWISE SPECIFIED		THIRD ANGLE PROJECTION ANSI 14.5M		SHOT WEIGHT: 14.0 LBS.	NOTES: 1.) .235 NOMINAL WALL 2.) BLACK COLOR
POLYETHYLENE ±1% @ 68°F				SHIPPING WEIGHT: 14.0 LBS.	
METAL DECIMAL ± .125" FRACTION ± 1/4" ANGLE ± 1°				FINISH: SB	

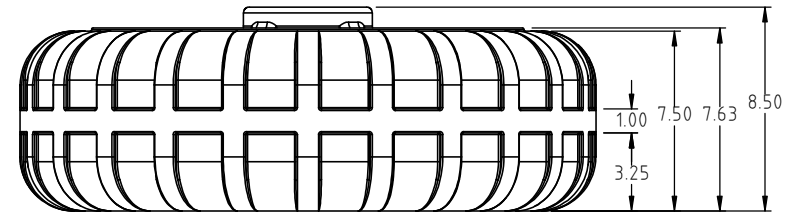
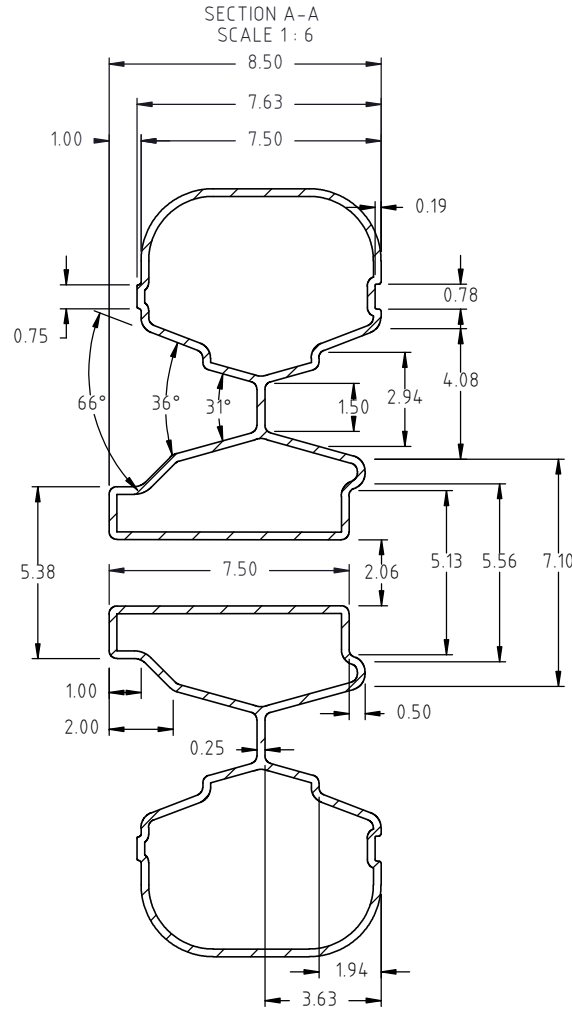

**Den Hartog**  
INDUSTRIES, INC.

Ace Roto-Mold Injection Molding Blow Molding Sowjoy

4010 HOSPERS DRIVE S. BOX 425, HOSPERS, IOWA 51238-0425

DESCRIPTION	HEAVY DUTY 24" DIA. DOCK WHEEL	
SCALE	N.S.	PART NO. DWBM-24HD