

Copyright. All information furnished within this document, electronic file or design correspondence is the property of Den Hartog industries, Inc. and shall not be used, disclosed to others or copied without the expressed written consent of Den Hartog Industries, Inc.

KEY	PART NUMBER	MATERIAL	DESCRIPTION	QTY.
1	FM1800-SKS-1	C06X82	6" CHANNEL	2 PCS, 109.50"(219 IN)
2	FM1800-SKS-2	C06X82	6" CHANNEL	4 @ 60"(240 IN)
3	FM1800-SKS-3	S-2500	1/4" SHEET	10" X 20.13"(201.25 SI)
4	FM1800-SKS-4	S-2500	1/4" SHEET	6 @ 10" X 7.50"(450 SI)
5	FM1800-SKS-5	S-2500	1/4" SHEET	4 @ 10" X 14.25"(580 SI)
6	FM1800-SKS-6	S-2500	1/4" SHEET	4 @ 10" X 10.25"(429 SI)
7	FS10026	S-1875	RH RETAINER	2
8	FS10027	S-1875	LH RETAINER	2
9	12411	S-2500	5 X 5 GUSSET	4
10	FM1800-SKS-10	C06X82	6" CHANNEL	60 IN
11	FM1800-SKS-11	C06X82	6" CHANNEL	60 IN
12	FM1800-SKS-12	C06X82	6" CHANNEL	60 IN
13	FM1800-SKS-13	C06X82	6" CHANNEL	60 IN

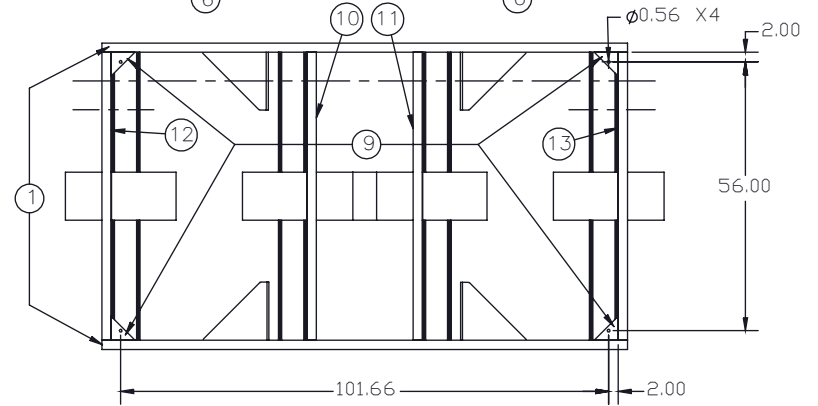
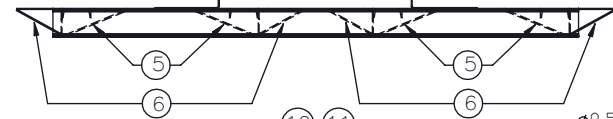
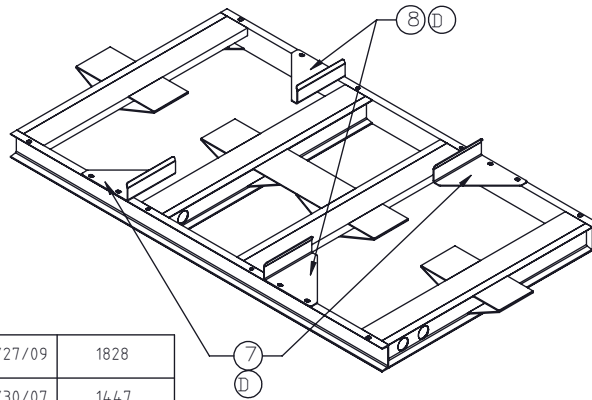
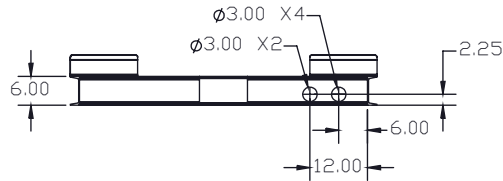
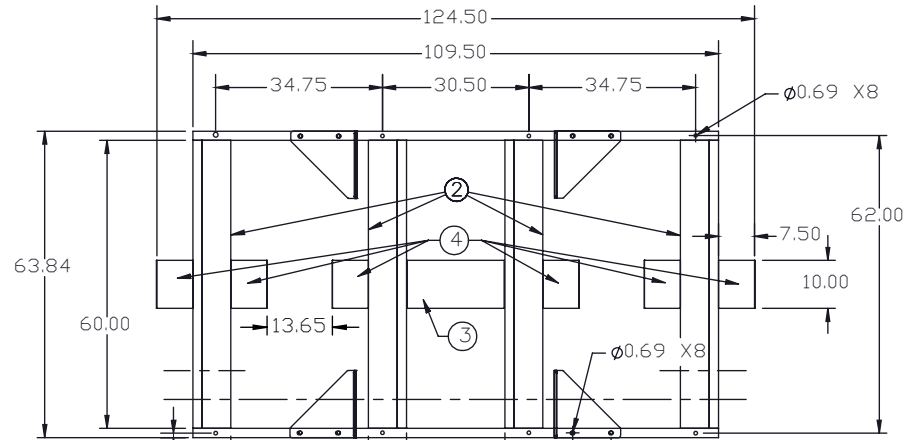

E	COMPONENT INFORMATION ADDED TO TABLE DRAWING TEMPLATE UPDATED.	ADH 3/27/09	1828
D	CORRECTED KEYS 7 & 8	ADH 8/30/07	1447
C	ADDED BILL OF MATERIALS	NVE 8/3/06	
B	NEW PART NO.	10/27/04	
A	NEW LENGTH	9/14/04	
REV	DESCRIPTION	BY / DATE	CCN

DRAWN / DATE	MATERIAL
REH 12/19/01	
APPRD. / DATE	
REH 12/19/01	

ALL DIMENSIONS ARE IN DECIMAL INCHES TOLERANCES UNLESS OTHERWISE SPECIFIED

POLYETHYLENE  
±1% @ 68°F

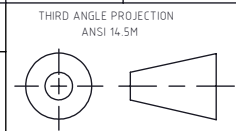

SHOT WEIGHT:  
SHIPPING WEIGHT:  
FINISH:

NOTES:



**Den Hartog**  
INDUSTRIES, INC.

Ace Roto-Mold Injection Molding Blow Molding Sowjoy

4010 HOSPERS DRIVE S. BOX 425, HOSPERS, IOWA 51238-0421

DESCRIPTION	TANK SKID FOR 1800 GALLON LEG TANK	
SCALE	N.S.	PART NO. FM1800-SKS