

Copyright. All information furnished within this document, electronic file or design correspondence is the property of Den Hartog industries, Inc. and shall not be used, disclosed to others or copied without the expressed written consent of Den Hartog Industries, Inc.

KEY	PART NUMBER	DESCRIPTION	QTY.
1	FS2350/3250-SK-1	END CHANNEL	2
2	FM2350/3250-SK-2	INNER CHANNEL	2
3	FM2350/3250-SK-3	FORMED SUPPORT CHANNEL	4
4	FM2350/3250-SK-4	INNER FORMED CHANNEL	2
5	FS2350/3250-SK-5	FILLER PLATE	16
6	FM2350/3250-SK-6	FORMED SUPPORT CHANNEL-LONG	4
7	FM2350/3250-SK-8	BASE SUPPORT TUBE	4
8	SJ19121	BRACKET	8
9	12847	8" X 8" GUSSET	4
10	FS10026	RETAINING PLATE-RIGHT	2
11	FS10027	RETAINING PLATE-LEFT	2
12	FS2350/3250-SK-12	OUTER CHANNEL	2

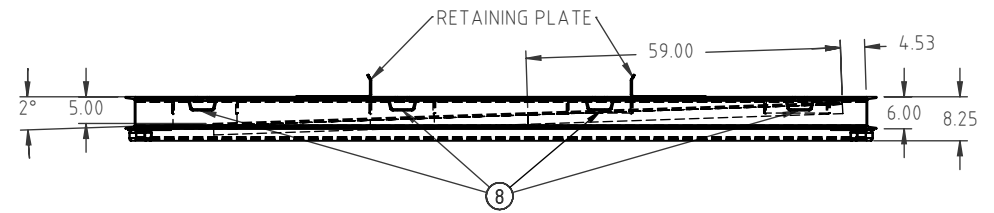

				DRAWN / DATE ADH 4/23/10	MATERIAL
				APPRD. / DATE REH 5/12/10	
REV	DESCRIPTION	BY / DATE	CCN		
ALL DIMENSIONS ARE IN DECIMAL INCHES TOLERANCES UNLESS OTHERWISE SPECIFIED		THIRD ANGLE PROJECTION ANSI 14.5M		SHOT WEIGHT:	NOTES:
POLYETHYLENE		METAL DECIMAL ± .125" FRACTION ± 1/4" ANGLE ± 1°		SHIPPING WEIGHT: 1060 LB.	
±1% @ 68°F		[Symbol]		FINISH: BLACK POWDER COAT	

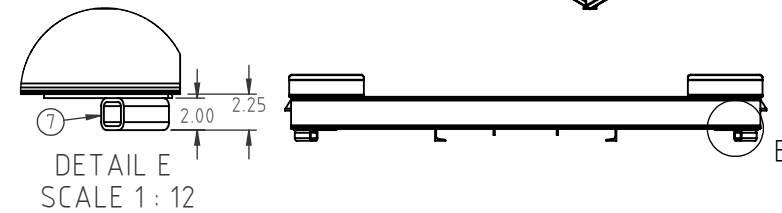
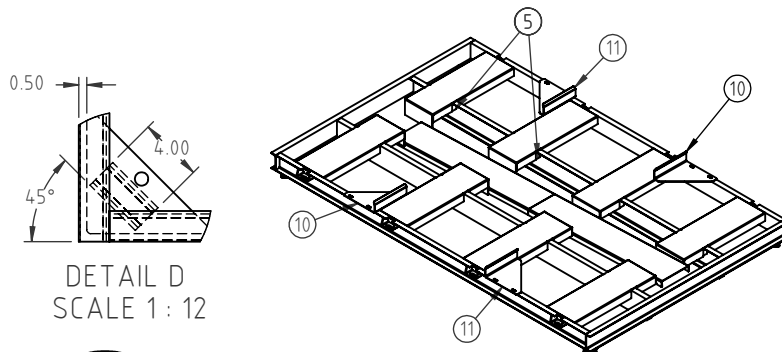
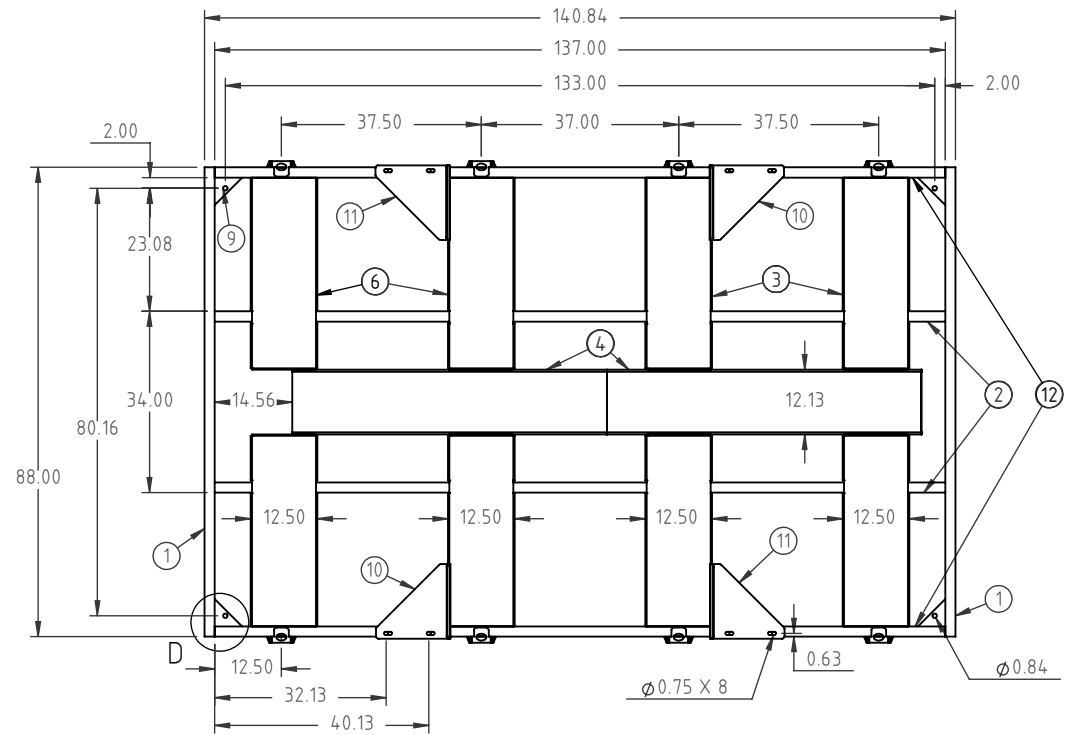

**Den Hartog**  
INDUSTRIES, INC.

Ace Roto-Mold Injection Molding Blow Molding Sowjoy

4010 HOSPERS DRIVE S. BOX 425, HOSPERS, IOWA 51238-0421

DESCRIPTION SKID FOR 2350 & 2750 & 3250 LEG TANK-END DRAIN	
SCALE N.S.	PART NO. FM2350/3250-SKE