

PROPRIETARY DATA

PROPERTY OF ACE ROTO-MOLD MFG., INC. INFORMATION FURNISHED HEREIN IS THE PROPERTY OF ACE ROTO-MOLD MFG., INC. AND SHALL NOT BE USED, DISCLOSED TO OTHERS, OR COPIED WITHOUT THE EXPRESSED WRITTEN CONSENT OF ACE ROTO-MOLD MFG., INC. ALL RIGHTS RESERVED.

| # | DESCRIPTION | PART NO. | FS1800-2W |
|---|-----------------|-------------------------|-----------|
| 1 | 2 HOODS | FS062-HP-925 | A |
| 2 | 2 HOODS | FS062-HP-1800C | |
| 3 | CONNECT PLATE | FS-1800-CP | |
| 4 | SKID | FS1800-SKW | |
| 5 | 2 TANKS NO/SUMP | FSA0900-FW / FSB0900-FW | |

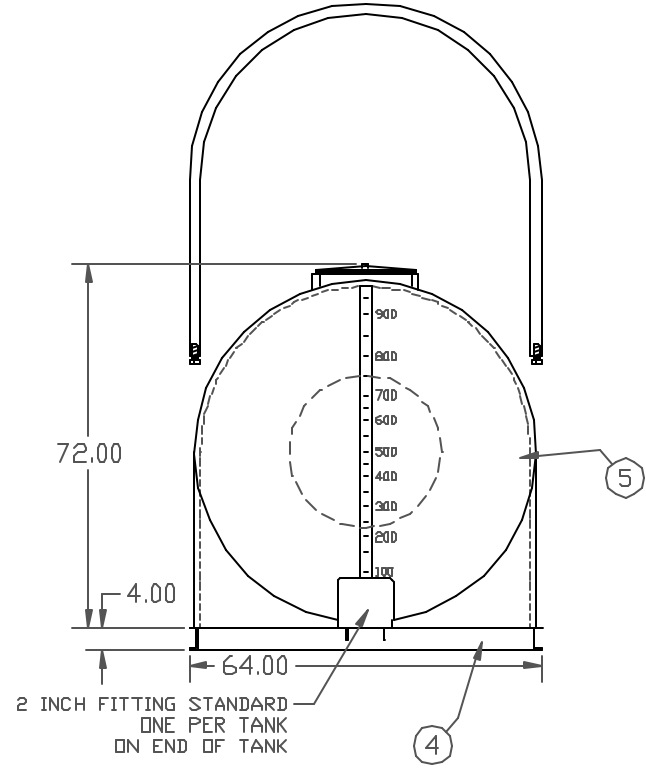
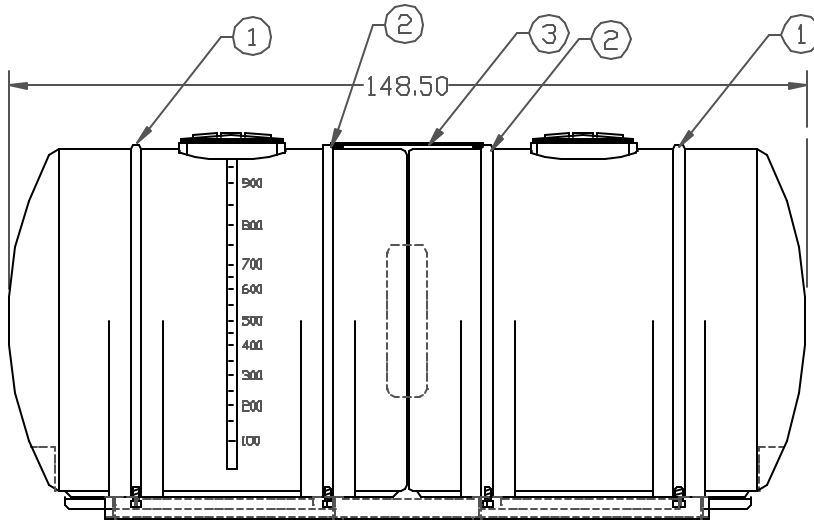

1800 GAL. TWO TANKS

CAUTION: TWO COMPARTMENT TANKS MUST BE PLUMBED TO DRAIN EQUALLY. DO NOT USE TANKS AS INDIVIDUAL STORAGE COMPARTMENTS.

| REV | DESCRIPTION | DATE | APPRD | DRAWN / DATE | MATERIAL |
|-----|----------------------------|---------|-------|------------------------------|---|
| A | TANK WAS FS1925-DW CCN1293 | 3/19/17 | GWC | DHJ 11/7/06 | HOPE OR EQUIVALENT REFERENCE MATERIAL DATA SHEET FOR SPECIFIC PROPERTIES. |
| A | REMOVE TOLERANCE | 3/19/17 | GWC | APPRD. / DATE REH 4/11/17 | |
| | | | | | |

ALL DIMENSIONS ARE IN DECIMAL INCHES
TOLERANCES UNLESS OTHERWISE SPECIFIED

THIRD ANGLE PROJECTION
ANSI 14.5M

NOTES:



ACE ROTO-MOLD
A DIVISION OF DEN HARTOG INDUSTRIES, INC.
4018 HWY. 61 BLVD., BOX 421, HOSPERS, IOWA 51238

CLIENT / DESCRIPTION
1800 GALLON FREE STANDING TANK

| | |
|---------------|-----------------------|
| SCALE N.S. | PART NO. FS1800-2W |
|---------------|-----------------------|