

Copyright. All information furnished within this document, electronic file or design correspondence is the property of Den Hartog industries, Inc. and shall not be used, disclosed to others or copied without the expressed written consent of Den Hartog Industries, Inc.

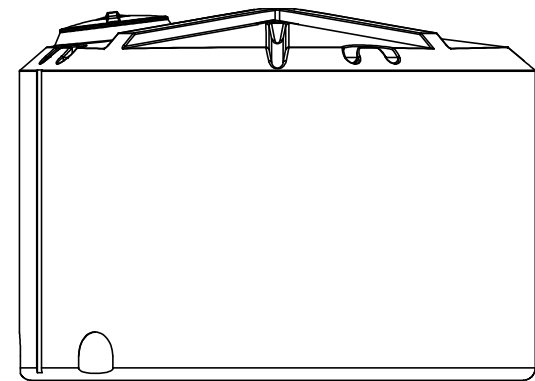

B	DESCRIPTION GALLONS CORRECTED. DRAWING TEMPLATE UPDATED.	ADH 8/16/16	3277	DRAWN / DATE DHJ 1/22/03	MATERIAL HDPE OR EQUIVALENT REFERENCE MATERIAL DATA SHEET FOR SPECIFIC PROPERTIES.
A	UPDATE DIAMETER.	8/30/06		APPRD. / DATE ADH 11/09/07	
REV	DESCRIPTION	BY / DATE	CCN		
ALL DIMENSIONS ARE IN DECIMAL INCHES TOLERANCES UNLESS OTHERWISE SPECIFIED		THIRD ANGLE PROJECTION ANSI 14.5M		SHOT WEIGHT: 207.00 LBS	NOTES: 1.) 1.5 SPECIFIC GRAVITY 2.) 0.245 NOM. WALL
POLYETHYLENE $\pm 1\%$ @ 68°F	METAL DECIMAL $\pm .125$ " FRACTION $\pm 1/4$ " ANGLE $\pm 1^\circ$			SHIPPING WEIGHT: 209.00 LBS	
				FINISH:	

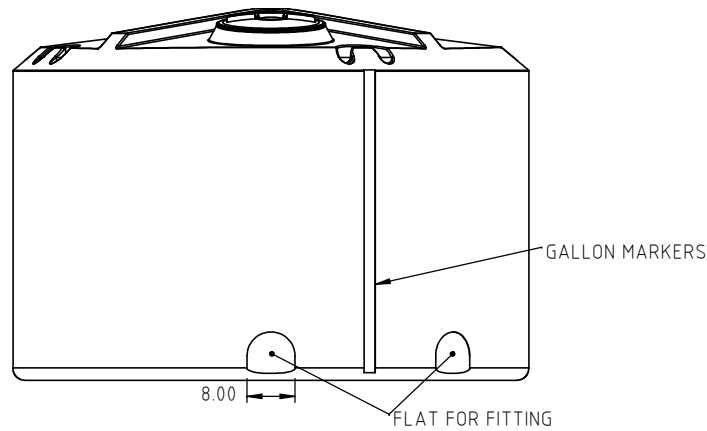
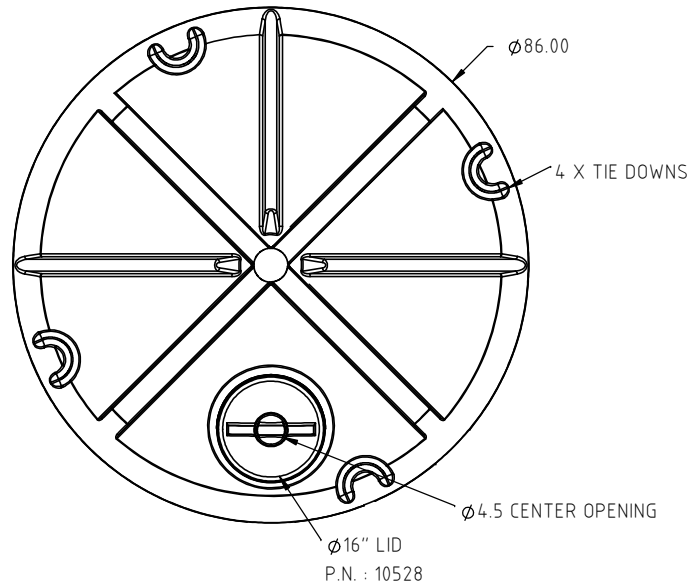

Den Hartog
INDUSTRIES, INC.

Ace Roto-Mold Injection Molding Blow Molding Sowjoy

4010 HOSPERS DRIVE S. BOX 425, HOSPERS, IOWA 51238-0425

DESCRIPTION B	1350 GALLON GUSSET TANK	
SCALE	N.S.	PART NO. GV01350-86