

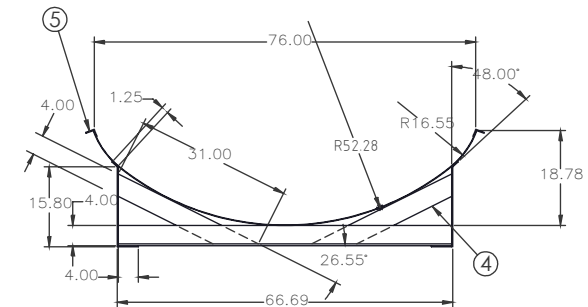

Copyright: All information furnished within this document, electronic file or design correspondence is the property of Den Hartog industries, Inc. and shall not be used, disclosed to others or copied without the expressed written consent of Den Hartog Industries, Inc.

KEY	PART NUMBER	MATERIAL	DESCRIPTION	QTY.
1	HE1000-C-1	S-12GA	SHEET, 12 GA	71.5" X 88.5"(6327.75 SI)
2	HE1000-C-2	S-12GA	SHEET, 12 GA	2.5 X 88.5"(221.25 SI)
3	HE1000-C-3	B02500X20000	FLAT, 1/4 X 2	2 @ 31.375"(62.75 IN)
4	HE1000-C-4	B02500X40000	FLAT, 1/4 X 4	6 @ 24"(144 IN)
5	HE1000-C-5	A01875X20000	ANGLE, 3/16 X 2	2 @ 74"(148 IN)
6	HE1000-C-6	A02500X40000	ANGLE, 1/4 X 4	4 @ 66.25"(265 IN)
7	SJ17011	S-10GA	SHEET, 10 GA	2 @ 21.125" X 74"(3126.5")

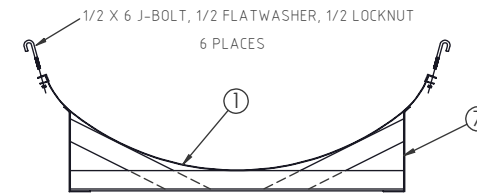
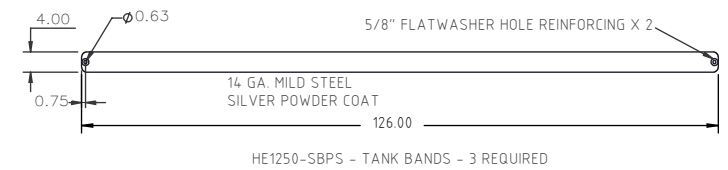
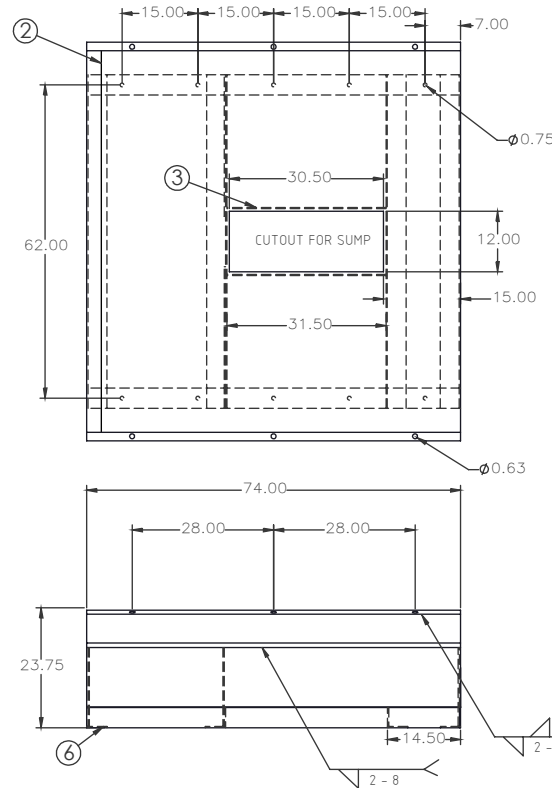

				DRAWN / DATE ADH 8/13/08	MATERIAL
				APPRD. / DATE REH 8/14/08	
REV	DESCRIPTION	BY / DATE	CCN	SHOT WEIGHT:	NOTES: 1) THE 1000 GALLON CRADLE AND 1250 GALLON CRADLE ARE THE SAME CRADLE BUT REQUIRE DIFFERENT TANK BANDS
	ALL DIMENSIONS ARE IN DECIMAL INCHES TOLERANCES UNLESS OTHERWISE SPECIFIED			THIRD ANGLE PROJECTION ANSI 14.5M	
	POLYETHYLENE ±1% @ 68°F			METAL DECIMAL ± .125" FRACTION ± 1/4"	



Den Hartog

INDUSTRIES, INC.

Ace Roto-Mold Injection Molding Blow Molding Sowjoy

4010 HOSPERS DRIVE S. BOX 425, HOSPERS, IOWA 51238-0421

DESCRIPTION 1250 GALLON ELLIPTICAL CRADLE WITH 1250 BAND	
SCALE N.S.	PART NO. HE1250-C