

PROPRIETARY DATA

PROPERTY OF DEN HARTOG MFG, INC. INFORMATION FURNISHED HEREIN IS THE PROPERTY OF ACE ROTO-MOLD MFG, INC. AND SHALL NOT BE USED, DISCLOSED TO OTHERS, OR COPIED WITHOUT THE EXPRESSED WRITTEN CONSENT OF ACE ROTO-MOLD MFG, INC. ALL RIGHTS RESERVED.

KEY	PART NUMBER	MATERIAL	DESCRIPTION	QTY.
1	HZ0110-C-1	S-14GA	SHEET, 14GA	4 @ 1" X 1 3/4"(7 IN)
2	HZ0110-C-2	S-14GA	SHEET, 14GA	4 @ 1" X 3 1/2"(14 IN)
3	SJHZ0110C-1	A01250X10000	ANGLE, 1/8" X 1"	2 @ 33"(66 IN)
4	SJHZ0110C-3B	S-14GA	SHEET, 14GA	2 @ 10 7/8" X 30"(652.50 SI)
5	SJHZ0110C-6	S-14GA	SHEET, 14GA	2 @ 8" X 34"(544 SI)

HZ0110-C

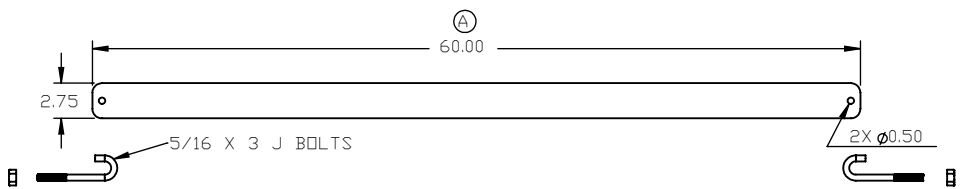
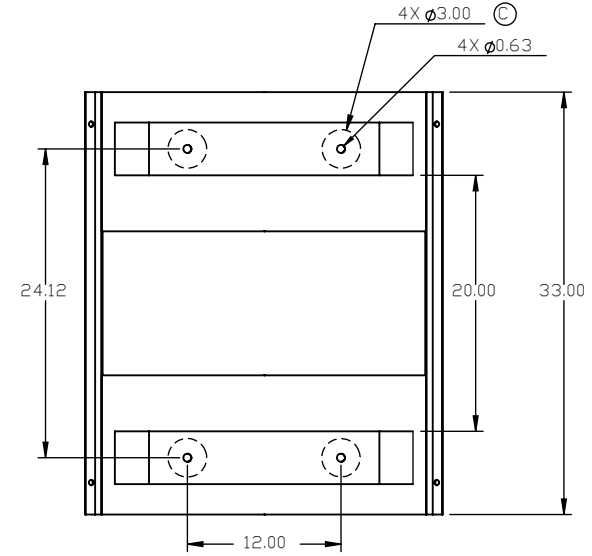
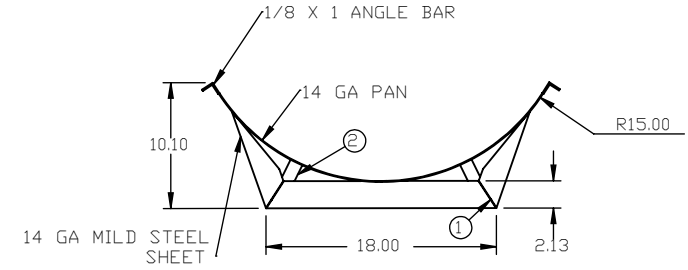
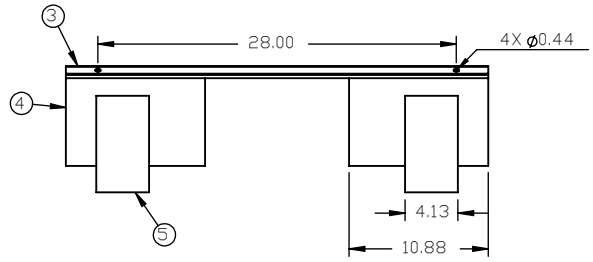

C	3" PAN ACCESS HOLES ADDED	ADH 4/22/09	1858	DRAWN / DATE	MATERIAL
B	TOLERANCE WAS 1% @ 68°F	GWC 3/14/07		ADH 8/7/07	
A	BAND LENGTH WAS 59	4/10/06		APPRD. / DATE	
REV	DESCRIPTION	BY / DATE	CCN	REH 11/26/07	

Den Hartog
INDUSTRIES, INC.

Ace Roto-Mold Injection Molding Blow Molding Sowjoy

4010 HOSPERS DRIVE S. BOX 425, HOSPERS, IOWA 51238-0421

ALL DIMENSIONS ARE IN DECIMAL INCHES
TOLERANCES UNLESS OTHERWISE SPECIFIED

DECIMAL ± .125"
FRACTION ± 1/4"
ANGLE ± 1°

THIRD ANGLE PROJECTION
ANSI 14.5M

NOTES:

DESCRIPTION	CRADLE FOR 110 GALLON HORIZONTAL TANK	
SCALE	N.S.	PART NO. HZ0110-C