

**PROPRIETARY DATA**  
 INFORMATION FURNISHED HEREIN IS THE PROPERTY OF  
 DEN HARTOG INDUSTRIES INC. AND SHALL NOT BE USED,  
 DISCLOSED TO OTHERS, OR COPIED WITHOUT EXPRESSED  
 WRITTEN CONSENT OF DEN HARTOG IND. ALL RIGHTS RESERVED.

INF D15-19  
 A

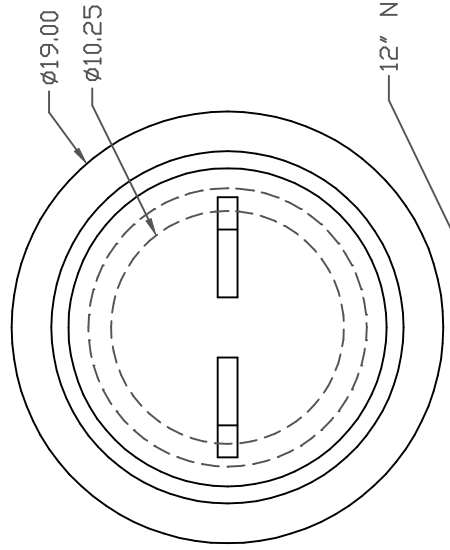

12" NONVENTED LID

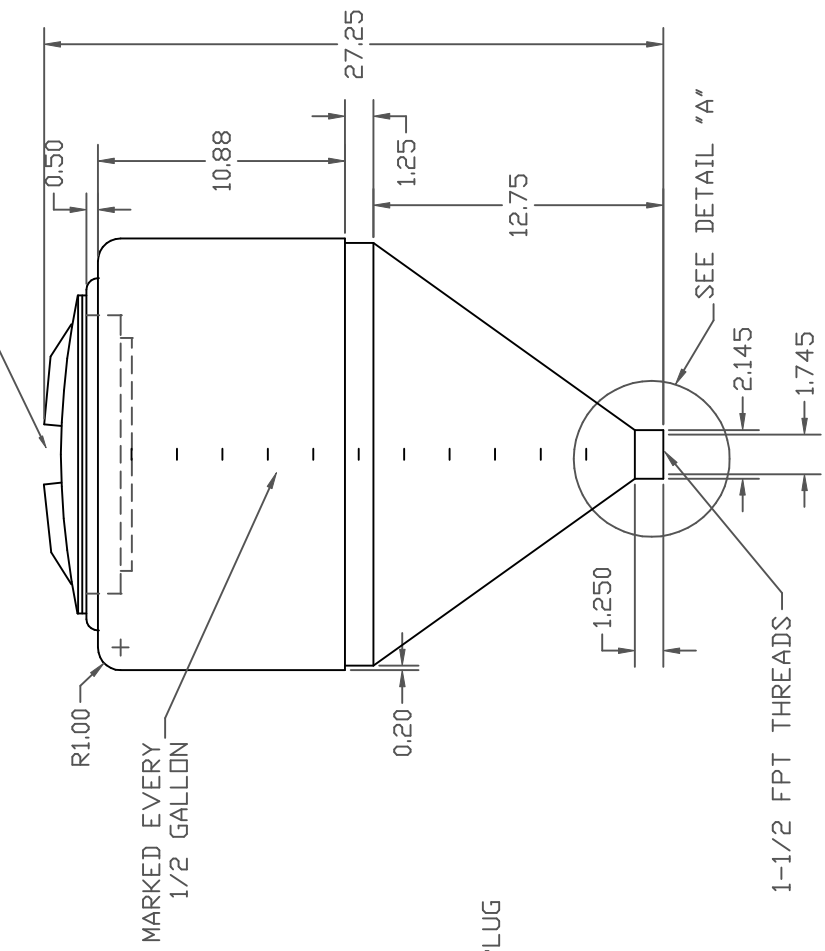

MARKED EVERY 1/2 GALLON

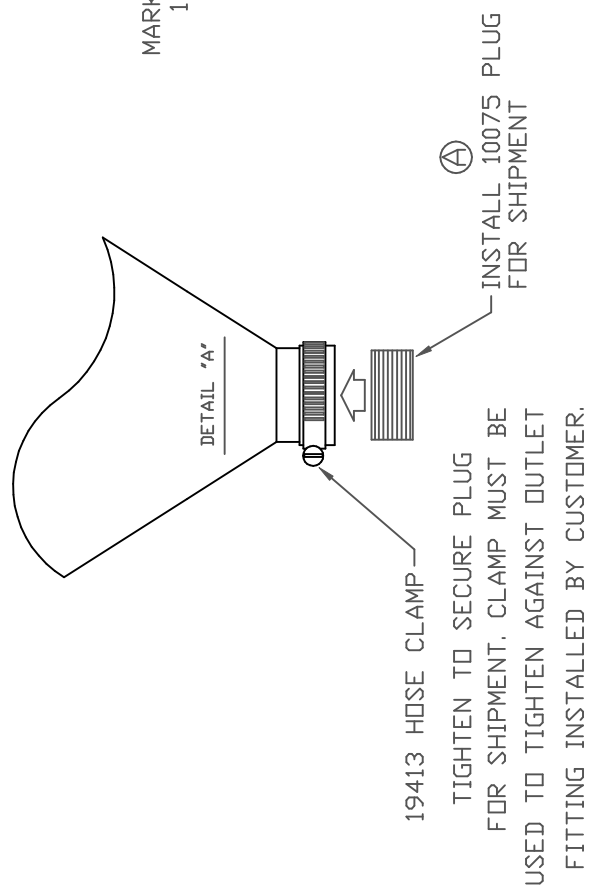

<b>Ace Roto-Mold</b> A DIVISION OF DEN HARTOG INDUSTRIES, INC. 4010 HOSPERS DRIVE SOUTH, BOX 425, HOSPERS, IOWA 51238		<b>CLIENT / DESCRIPTION</b> 15 GALLON INDUCTOR FULL DRAIN	
<b>MATERIAL</b> POLYETHYLENE 10 LBS.		<b>SCALE</b> NONE	
<b>NOTES:</b> 0.20 WALL		<b>PART NO.</b> INF D15-19	
<b>REV</b> A	<b>DESCRIPTION</b> 10075 PLUG WAS 19412 PLUG	<b>DATE APPRD.</b> ADH 1/28/08	<b>DATE</b> DHJ 2/7/07
ALL DIMENSIONS ARE IN DECIMAL INCHES TOLERANCES UNLESS OTHERWISE SPECIFIED ± 1 % @ 68°F		<b>THIRD ANGLE PROJECTION</b> ANSI 14.5M	