

Copyright. All information furnished within this document, electronic file or design correspondence is the property of Den Hartog industries, Inc. and shall not be used, disclosed to others or copied without the expressed written consent of Den Hartog Industries, Inc.

ITEM NO.	PART NUMBER	DESCRIPTION	QTY.
1	INFD7-10-ST-1	IN, STAND 7/10 LEG PIPE	2
2	INFD7-10-ST-2	IN, STAND 7/10 LEG PIPEW/HLE	1
3	INFD7-10-ST-3	IN, STAND 7/10 GAL RING	1
4	12582	PIPE PLUG, 1/2" BLACK	3
5	INFD7-10-ST-5	IN, STAND 7/10 GAL ROD	3
6	14060	INDUCTOR, BASE STRAP FULL DRN 7/10 GAL	3
7	J.313X3.00	J-BOLT, 5/16" X 3"	1
8	10280	NUT, 5/16" NYLOK ZINC	1

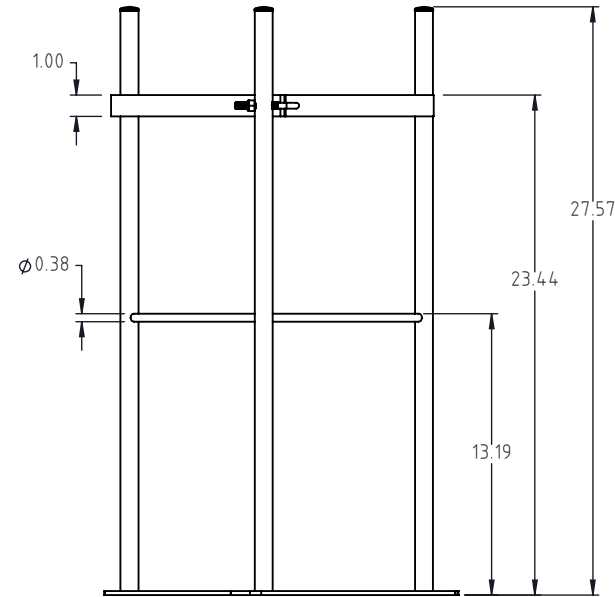
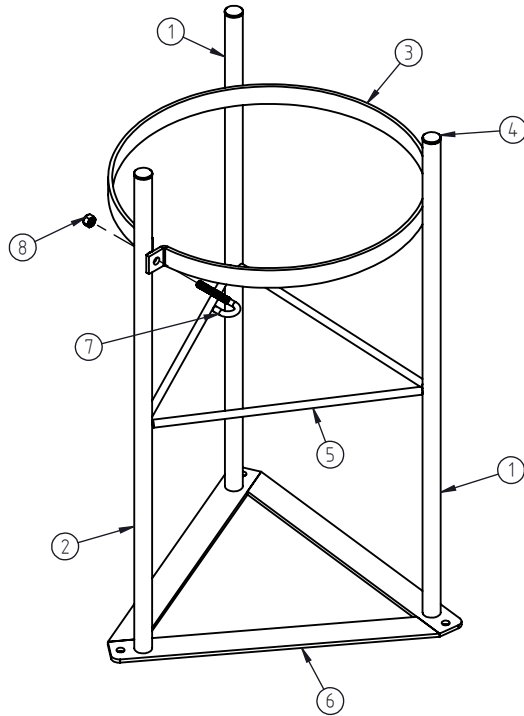
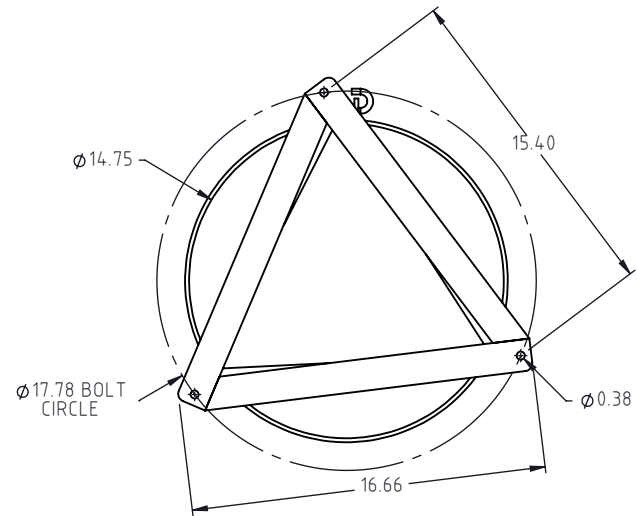

A	UPDATED SHEET FORMAT & LAYOUT	SRA	8/29/24	4633
REV.	DESCRIPTION	BY	DATE	CCN
ALL DIMENSIONS ARE IN DECIMAL INCHES TOLERANCES UNLESS OTHERWISE SPECIFIED		THIRD ANGLE PROJECTION ANSI 14.5M		
POLYETHYLENE	METAL			
±1% @ 68°F	DECIMAL ± .125" FRACTION ± 1/4" ANGLE ± 1°			

DRAWN / DATE	MATERIAL :
ADH 1/6/2014	SEE COMPONENTS
APPRD. / DATE	
REH 1/27/2014	
SHOT WEIGHT:	NOTES:
SHIPPING WEIGHT:	
12 LBS.	
FINISH:	
POWDERCOAT	

Den Hartog

INDUSTRIES, INC.

Ace Roto-Mold • Injection Molding • Blow Molding • Sowjoy
4010 HOSPERS DRIVE S. BOX 425, HOSPERS, IOWA 51238-0425

DESCRIPTION		IN, STAND 7/10 GAL FULL DRAIN	
SCALE	PART NO.	SHEET	
N.S.	INFD7-10-ST	1 OF 1	