

Copyright. All information furnished within this document, electronic file or design correspondence is the property of Den Hartog industries, Inc. and shall not be used, disclosed to others or copied without the expressed written consent of Den Hartog Industries, Inc.

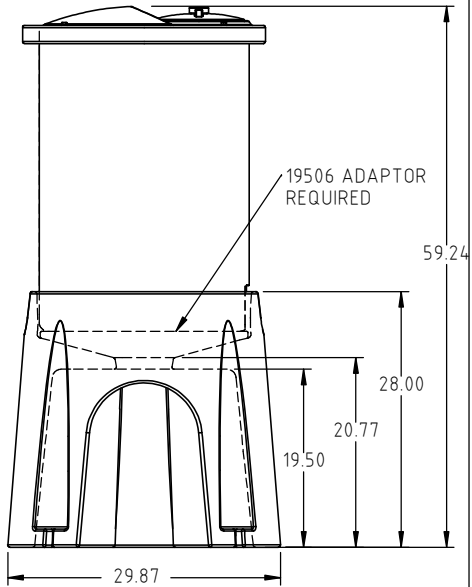

OC023-STP POLY STAND

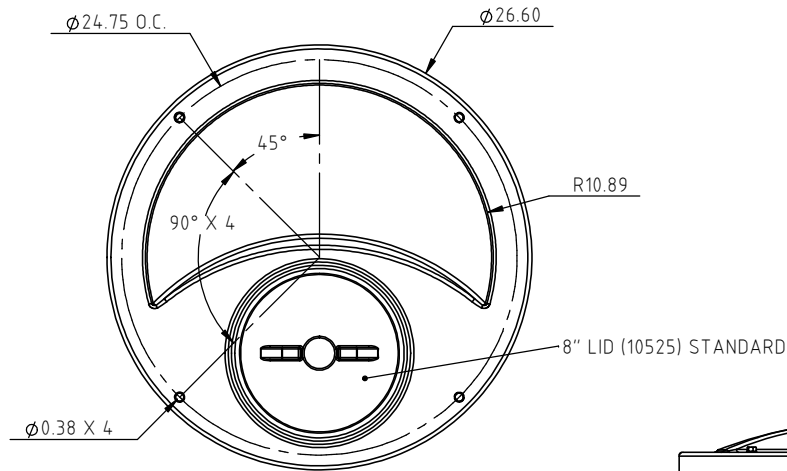
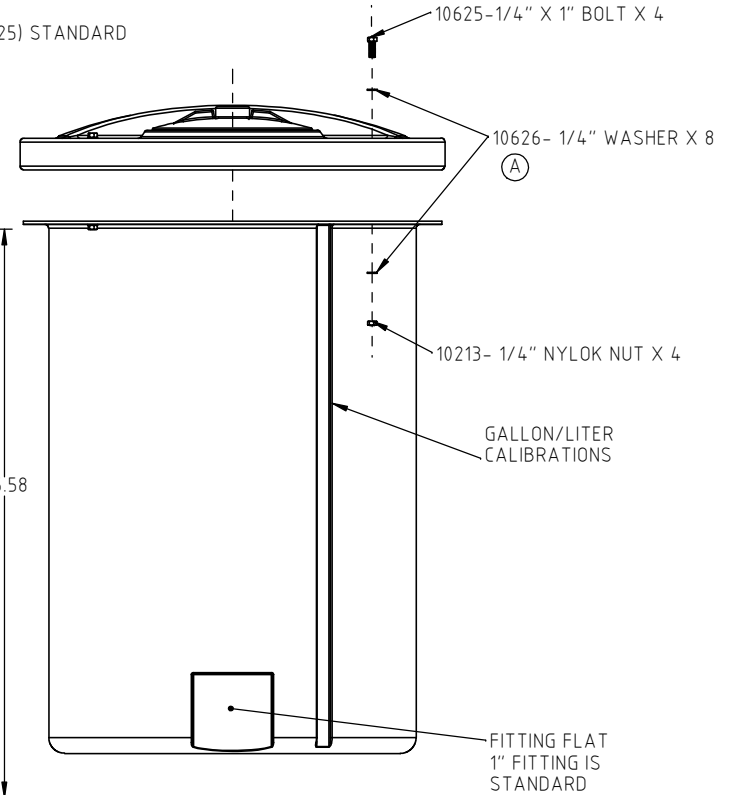
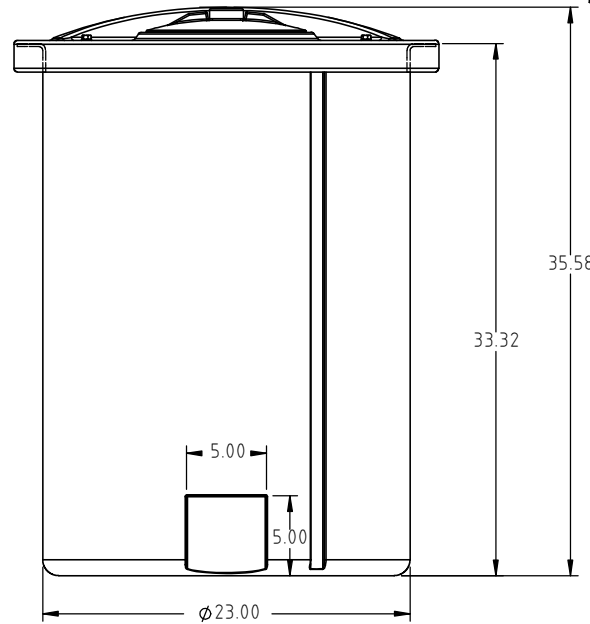

				DRAWN / DATE ADH 3/21/11	MATERIAL 10420
A	10626 WAS SJ10067	ADH 10/26/11	2311	APPRD. / DATE REH 4/18/11	
REV	DESCRIPTION	BY / DATE	CCN		
ALL DIMENSIONS ARE IN DECIMAL INCHES TOLERANCES UNLESS OTHERWISE SPECIFIED		THIRD ANGLE PROJECTION ANSI 14.5M		SHOT WEIGHT: 24.00 LBS	NOTES: 1.) 0.20 WALL THICKNESS
POLYETHYLENE		METAL DECIMAL ± .125" FRACTION ± 1/4" ANGLE ± 1°		SHIPPING WEIGHT: 26.00 LBS	
±1% @ 68°F				FINISH:	



Den Hartog
INDUSTRIES, INC.

Acro Roto-Mold Injection Molding Blow Molding Sowjoy

4010 HOSPERS DRIVE S. BOX 425, HOSPERS, IOWA 51238-0425

DESCRIPTION 23" DIA. X 55 GALLON VERTICAL TANK- OPEN TOP

SCALE N.S.

PART NO. OP0055-23