

Copyright. All information furnished within this document, electronic file or design correspondence is the property of Den Hartog industries, Inc. and shall not be used, disclosed to others or copied without the expressed written consent of Den Hartog Industries, Inc.

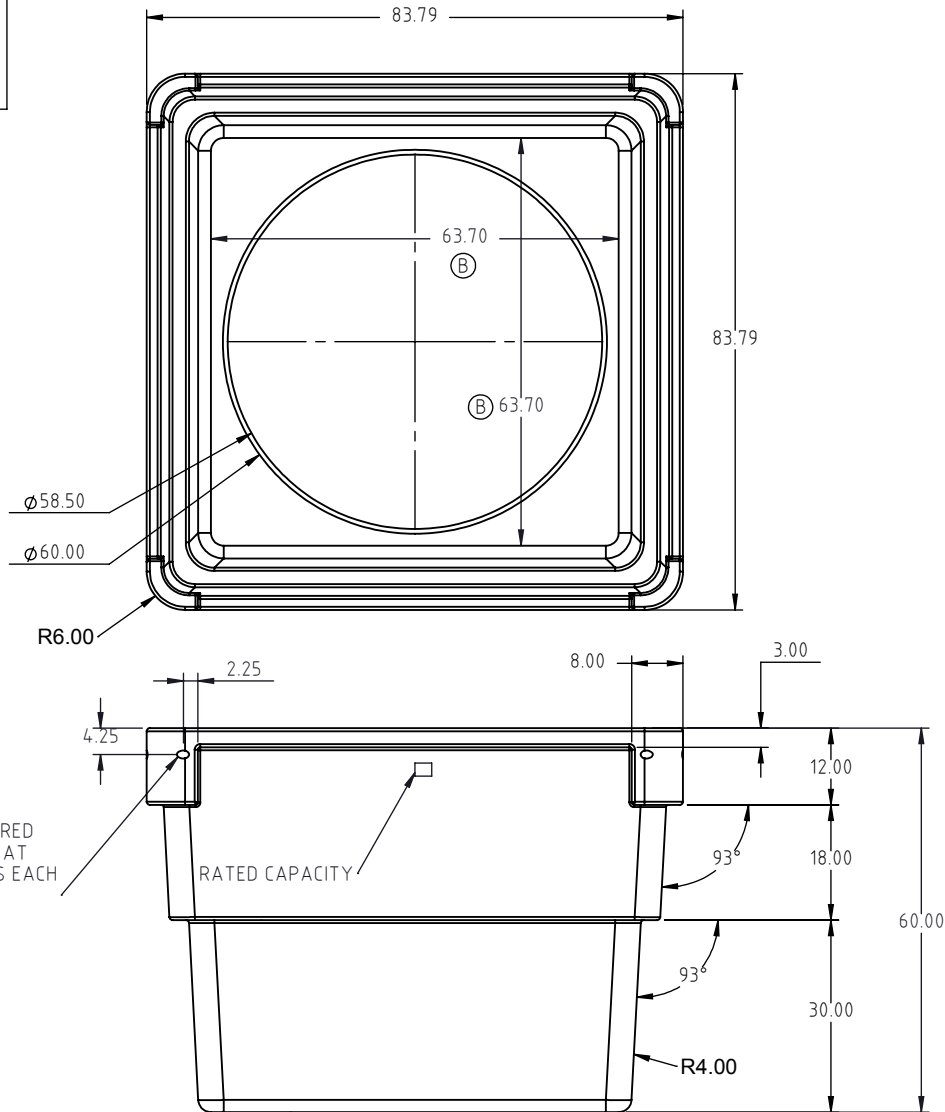

1.25 DIA. CORED HOLE THRU AT 45 DEGREES EACH CORNER

RATED CAPACITY

STACK 5 HIGH UPSIDE DOWN FOR STORAGE

B	INSIDE BASE DIMENSIONS ADDED	ADH 8/3/09	1902	DRAWN / DATE ADH 6/25/08	MATERIAL 10538 POWDER
A	ADDED CORNER HOLES	REH 1/5/09	1775	APPRD. / DATE REH 7/1/08	
REV	DESCRIPTION	BY / DATE	CCN		
ALL DIMENSIONS ARE IN DECIMAL INCHES TOLERANCES UNLESS OTHERWISE SPECIFIED		THIRD ANGLE PROJECTION ANSI 14.5M		SHOT WEIGHT: 375 LB.	NOTES: 1. NATURAL COLOR STD. 2. .425 WALL THICKNESS
POLYETHYLENE		METAL DECIMAL ± .125" FRACTION ± 1/4" ANGLE ± 1°		SHIPPING WEIGHT: 360 LB.	
±1% @ 68° F				FINISH: BEAD BLAST	



Den Hartog
INDUSTRIES, INC.

Ace Roto-Mold Injection Molding Blow Molding Sowjoy

4010 HOSPERS DRIVE S. BOX 425, HOSPERS, IOWA 51238-0421

DESCRIPTION 1325 GALLON CONTAINMENT TANK	
SCALE N.S.	PART NO. OP1325-RT