

Copyright. All information furnished within this document, electronic file or design correspondence is the property of Den Hartog industries, Inc. and shall not be used, disclosed to others or copied without the expressed written consent of Den Hartog Industries, Inc.

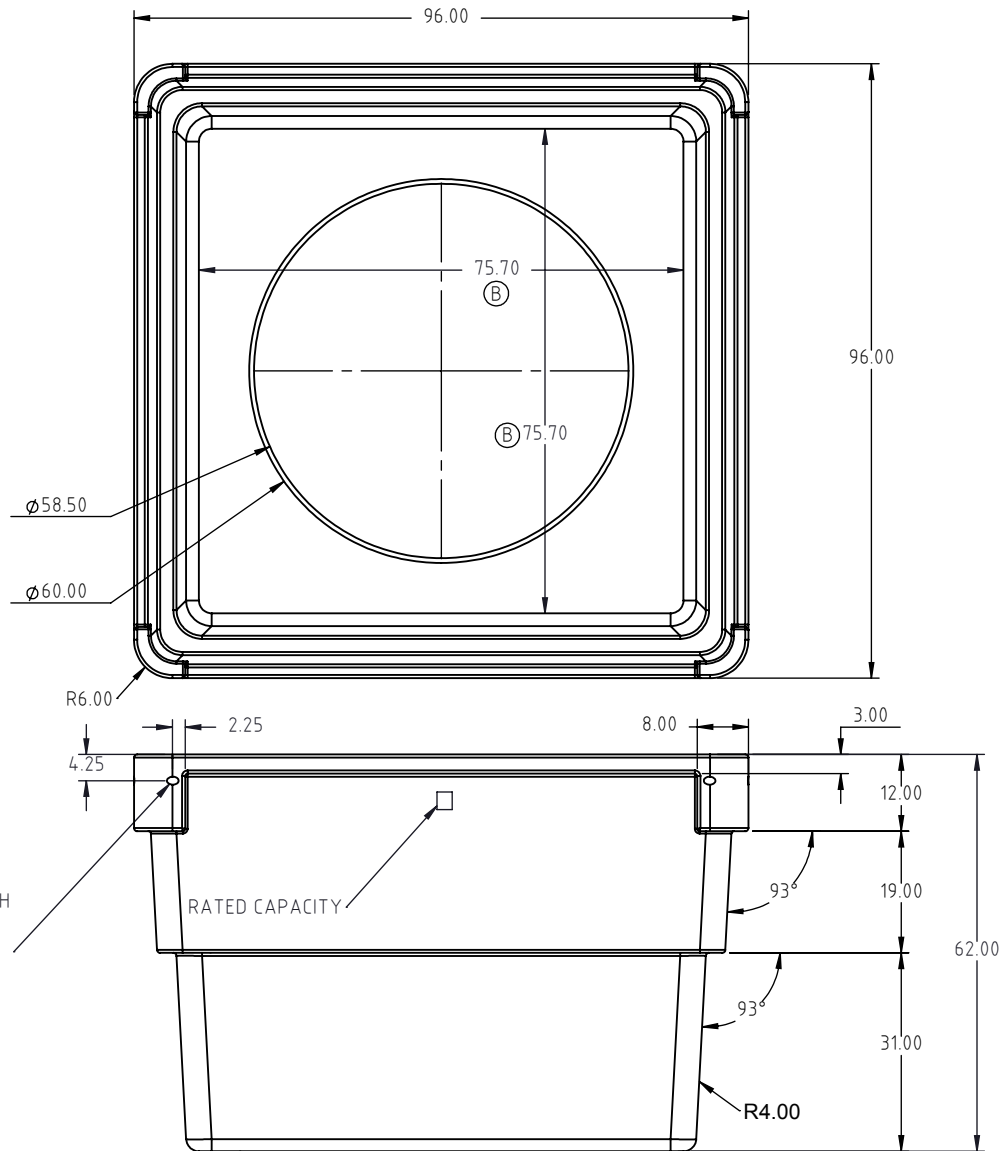

STACK 3 HIGH UPSIDE DOWN FOR STORAGE

				DRAWN / DATE ADH 6/25/08	MATERIAL 10538 POWDER
B	INSIDE BASE DIMENSIONS ADDED	ADH 8/3/09	1902	APPRD. / DATE REH 7/1/08	
A	ADDED CORNER HOLE	REH 1/5/09	1775		
REV	DESCRIPTION	BY / DATE	CCN		
ALL DIMENSIONS ARE IN DECIMAL INCHES TOLERANCES UNLESS OTHERWISE SPECIFIED		THIRD ANGLE PROJECTION ANSI 14.5M		SHOT WEIGHT: 540 LB.	NOTES: 1. NATURAL COLOR STD. 2. .500 WALL THICKNESS
POLYETHYLENE		METAL DECIMAL ± .125" FRACTION ± 1/4" ANGLE ± 1°		SHIPPING WEIGHT: 520 LB.	
±1% @ 68° F				FINISH: BEAD BLAST	



Den Hartog
INDUSTRIES, INC.

Ace Roto-Mold Injection Molding Blow Molding Sowjoy

4010 HOSPERS DRIVE S. BOX 425, HOSPERS, IOWA 51238-0421

DESCRIPTION 1825 GALLON CONTAINMENT TANK	
SCALE N.S.	PART NO. OP1825-RT