

Copyright. All information furnished within this document, electronic file or design correspondence is the property of Den Hartog Industries, Inc. and shall not be used, disclosed to others or copied without the expressed written consent of Den Hartog Industries, Inc.

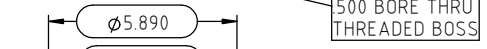

DETAIL A  
SCALE 1: 6

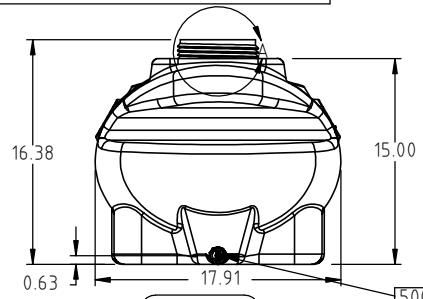
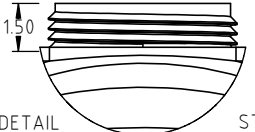

5" BUTTRESS THREAD DETAIL

STACKED HEIGHT

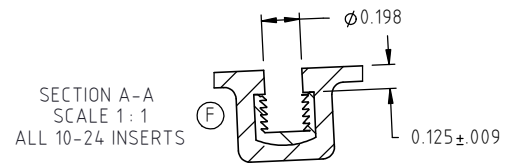
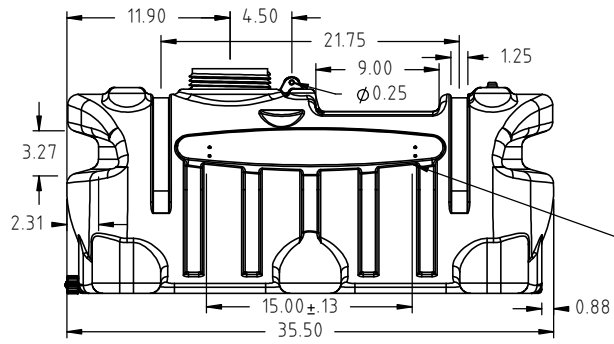
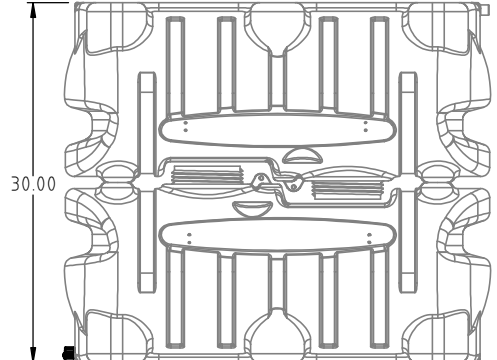

10-24 UNC THREADED BRASS INSERTS X 2  
(THIS SIDE ONLY) DHI P.N. 19001

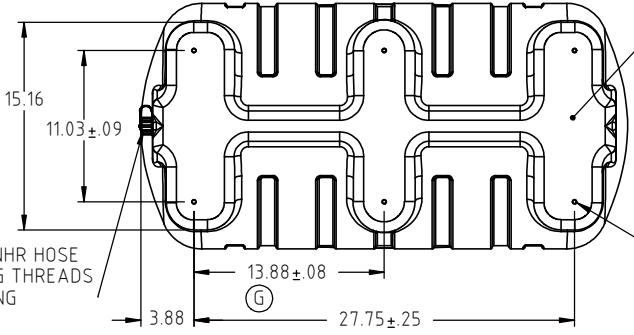

TANK BOTTOM SURFACE TO BE FLAT  
WITHIN .25 T.I.R.

NOTE:  
EXCEPT AS NOTED TOLERANCES ARE ± 2%  
OF DIMENSION NOTED

.75-11.5 NHR HOSE  
COUPLING THREADS  
X .75 LONG

313-18 UNC THREADED NYLON INSERTS X 6  
DHI P.N. 19382

LITER/GALLON INDICATORS

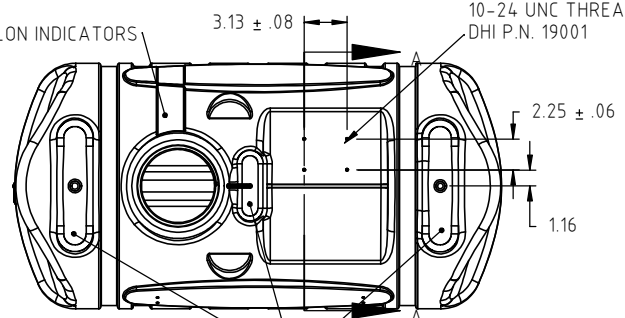

10-24 UNC THREADED BRASS INSERTS X 4  
DHI P.N. 19001

FLATS FOR PICKUP/RETURN LINE PLACEMENT

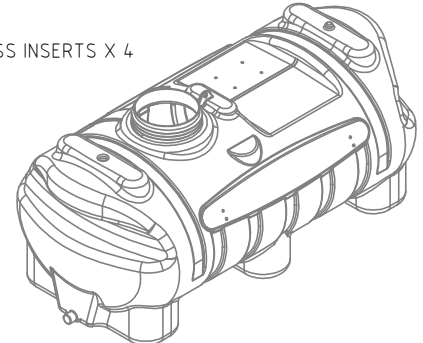

H	6 INSERTS CORRECTED FROM 4	ADH 9/21/16	3288
G	INSERT LOCATIONS CORRECTED	ADH 5/31/13	2627
F	INSERT DETAIL ADDED, DIMENSIONS DRAWING TEMPLATE UPDATED	ADH 4/23/13	2605
E	WEIGHT WAS 12.50 LB.	12/12/05	
D	19382 WAS 19000	6/15/05	
C	TOLERANCES CHANGED	6/15/05	
B	TOLERANCES CHANGED	8/20/02	
A	TOLERANCES CHANGED	1/30/02	
REV	DESCRIPTION	BY / DATE	CCN

DRAWN / DATE	MATERIAL
REH 11/13/00	MDP E
APPRD. / DATE	
REH 11/13/00	

ALL DIMENSIONS ARE IN DECIMAL INCHES  
TOLERANCES UNLESS OTHERWISE SPECIFIED

POLYETHYLENE

±1% @ 68°F

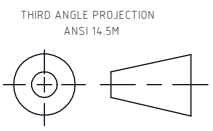

SHOT WEIGHT:	12 LBS
SHIPPING WEIGHT:	
FINISH:	

NOTES:  
1.) MIN. WALL .080



## Den Hartog

INDUSTRIES, INC.

Ace Roto-Mold Injection Molding Blow Molding Sowjoy

4010 HOSPERS DRIVE S. BOX 425, HOSPERS, IOWA 51238-0425

DESCRIPTION	25 GAL. SPOT SPRAYER TANK (BLOW MOLDED)	
SCALE	N.S.	PART NO. SB00025