

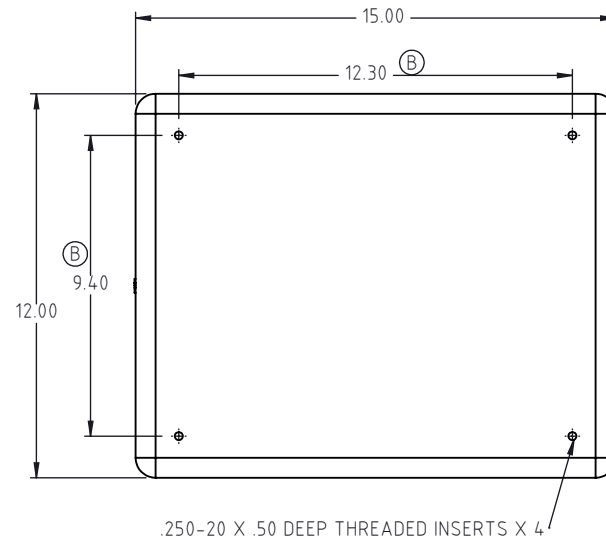

Copyright. All information furnished within this document, electronic file or design correspondence is the property of Den Hartog industries, Inc. and shall not be used, disclosed to others or copied without the expressed written consent of Den Hartog Industries, Inc.

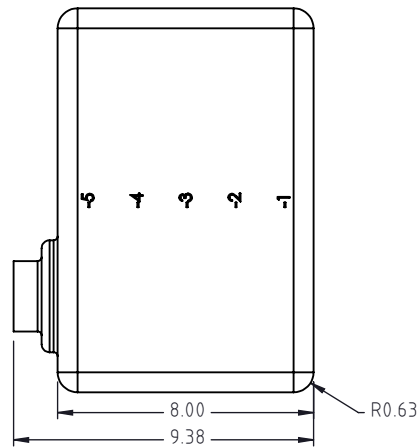

B	INSERT SPACNG DIMS CORRECTED UPDATED PRINT FORMAT	SAS	4/27/2023	4423	DRAWN / DATE DHJ 8/19/1999	MATERIAL: MOBIL 134
A	SHOT WEIGHT CORRECTED	ADH	2/16/09	1801	APPRD. / DATE REH 8/19/1999	
REV.	DESCRIPTION	BY	DATE	CCN		
ALL DIMENSIONS ARE IN DECIMAL INCHES TOLERANCES UNLESS OTHERWISE SPECIFIED		THIRD ANGLE PROJECTION ANSI 14.5M		SHOT WEIGHT: 5.00 LBS	NOTES:	
POLYETHYLENE		METAL		(A) SHIPPING WEIGHT:	1.) NATURAL COLOR	
±1% @ 68°F		DECIMAL ± .125" FRACTION ± 1/4" ANGLE ± 1°		FINISH: ERROR! SHIPPI NG WEIGHT	2.) NOM. WALL .150	

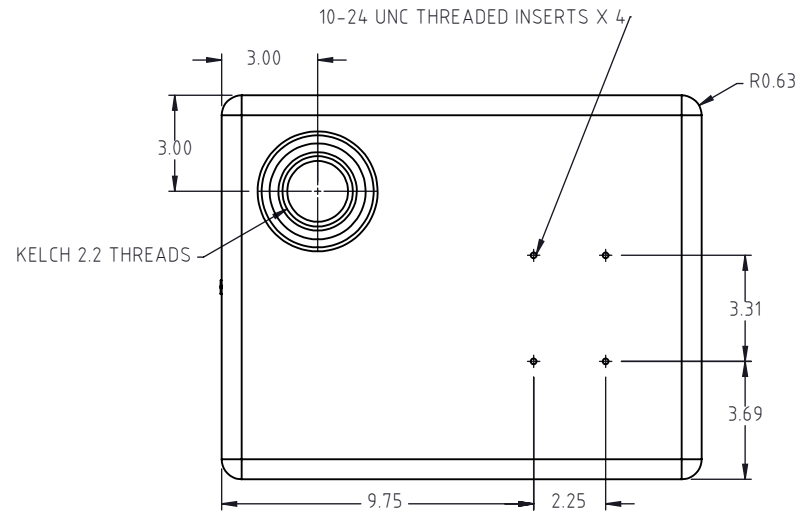
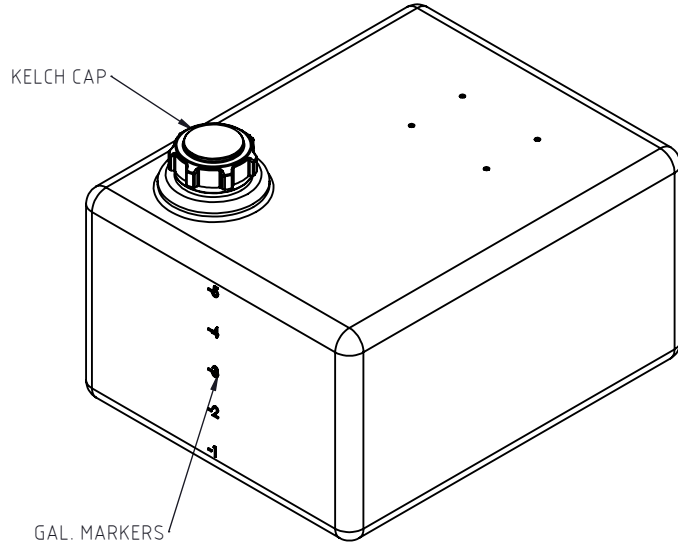

# Den Hartog

## INDUSTRIES, INC.

Ace Roto-Mold • Injection Molding • Blow Molding • Sowjoy  
4010 HOSPERS DRIVE S. BOX 425, HOSPERS, IOWA 51238-0425

DESCRIPTION 6 GAL. SPRAYER TANK		
SCALE N.S.	PART NO. SP0006-2P	SHEET 1 OF 1