

PROPRIETARY DATA

PROPERTY OF ACE ROTO-MOLD MFG. INC. INFORMATION FURNISHED HEREIN IS THE PROPERTY OF ACE ROTO-MOLD MFG. INC. AND SHALL NOT BE USED, DISCLOSED TO OTHERS, OR COPIED WITHOUT THE EXPRESSED WRITTEN CONSENT OF ACE ROTO-MOLD MFG. INC. ALL RIGHTS RESERVED.

SP0150-2TPP

A

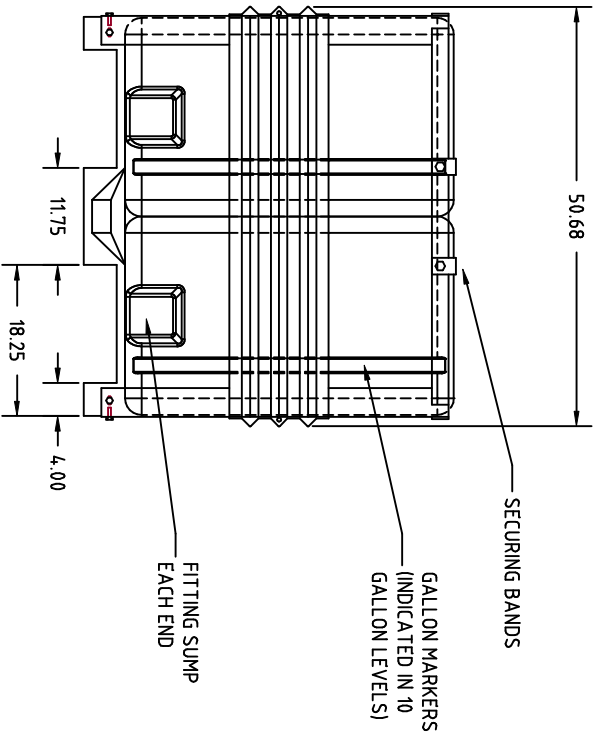
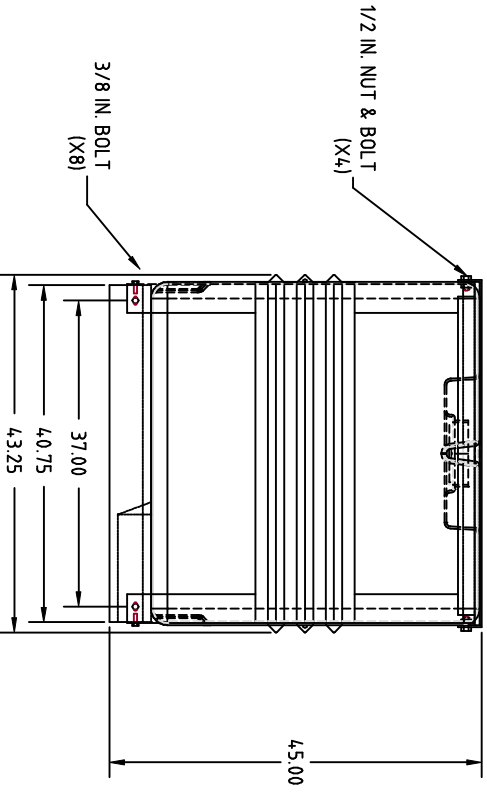
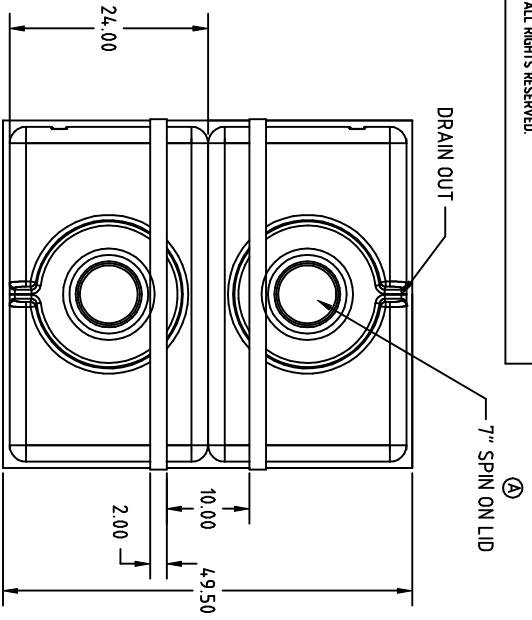

REV	DESCRIPTION	DATE	APPRD
A	CHANGE TO 7" LID	CCN 1308	6/29/07
			GWC

DRAWN / DATE	NVE 6/24/05
APPRD. / DATE	DHJ 9/21/05

MATERIAL

THIRD ANGLE PROJECTION
ANSI 14.5M

NOTES:
1. WEIGHT 356 LBS.

CLIENT / DESCRIPTION
150 GALLON PALLET PAK
2 TANKS, PALLET, FRAME

ALL DIMENSIONS ARE IN DECIMAL INCHES
TOLERANCES UNLESS OTHERWISE SPECIFIED

+ 1% @ 68° F

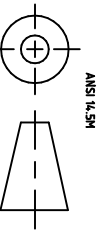

SCALE N.S.

PART NO. SP0150-2TPP