

© DEN HARTOG INDUSTRIES, INC.

Copyright. All information furnished within this document, electronic file or design correspondence is the property of Den Hartog industries, Inc. and shall not be used, disclosed to others or copied without the expressed written consent of Den Hartog Industries, Inc.

KEY	PART NUMBER	DESCRIPTION	QTY.
1	SP150-300PPFR	SP, PALLET PACK FRAME AND PALLET	1
2	SP0300-PPTK	SP, PALLET PACK 300 GALLON	1
3	SP300-PPTB	SP, PALLET PACK, TOP BAR	2
4	10126	NUT, 1/2"-13 GR 2 ZINC	4
5	12437	BOLT, 1/2" X 1" HEX GR5 ZINC	4

SP0300-PP

G

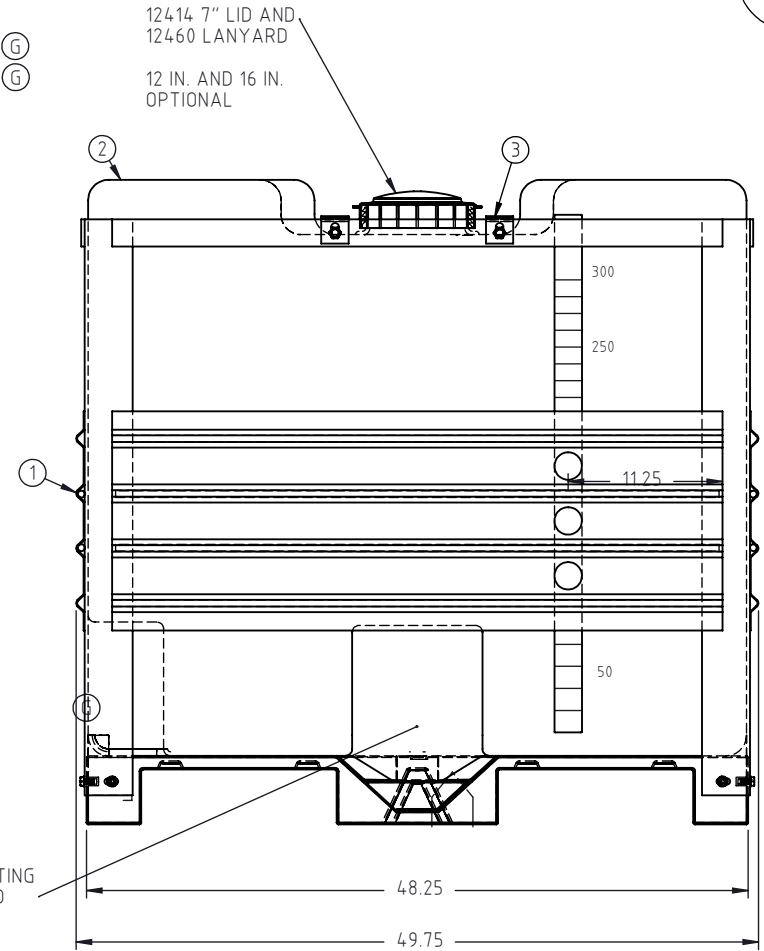
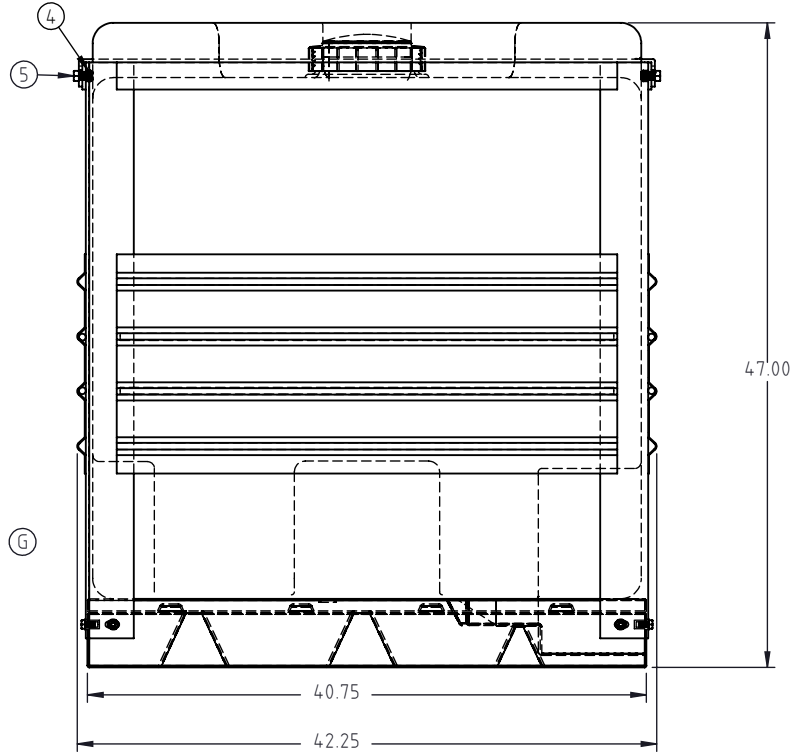

G	DRAWING TEMPLATE UPDATED, 10126 WAS SJ10252, FITTING SUMPS SHOWN	ADH 11/1/10	2123
F	UPDATE TITLE BLOCK	GWC 6/29/07	
E	CHANGE TO 7" LID	GWC 6/29/07	1308
D	ADD HARDWARE PART #	2/15/07	
C	ADD VIEW HOLES	9/5/06	
B	ADD LID OPTIONS	8/30/06	
A	UPDATE DRAWING	3/27/06	
REV	DESCRIPTION	BY / DATE	CCN

DRAWN / DATE	MATERIAL
EVAN 4/7/95	
APPRD. / DATE	
GWC 6/29/07	



Den Hartog
INDUSTRIES, INC.

Ace Roto-Mold Injection Molding Blow Molding Sowjoy

4010 HOSPERS DRIVE S. BOX 425, HOSPERS, IOWA 51238-0425

ALL DIMENSIONS ARE IN DECIMAL INCHES
TOLERANCES UNLESS OTHERWISE SPECIFIED

POLYETHYLENE

±1% @ 68°F

THIRD ANGLE PROJECTION
ANSI 14.5M

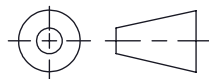

SHOT WEIGHT:	NOTES:
SHIPPING WEIGHT:	
270.00 LBS	
FINISH:	

DESCRIPTION	300 GAL. PALLET PACK	
SCALE	N.S.	PART NO. SP0300-PP