

© DEN HARTOG INDUSTRIES, INC.

Copyright. All information furnished within this document, electronic file or design correspondence is the property of Den Hartog Industries, Inc. and shall not be used, disclosed to others or copied without the expressed written consent of Den Hartog Industries, Inc.

SSPU0400-70

B

KEY	PART NUMBER	DESCRIPTION	QTY.
1	10527	12" VENTED LID ASSEMBLY	1
2	10873	LANYARD, SHORT BLACK	1
3	10284	SCREW, LID 18-8 SS	8
4	10108	INSERT, 3/8-16 ALUMINUM BLIND	12
5	10351	LABEL, ACE SMALL	1
6	10353	LABEL, WARNING	1
7	10357	LABEL, BARCODE 4" X 2"	1
8	14723	SPACE SAVER TORQUE LABEL	1
9	14935	LABEL, PROP 65	1
10	19496	NSF/ANSI/CAN 61 MARKING LABEL	1
11	XXXX	LABEL, INSPECTION	1

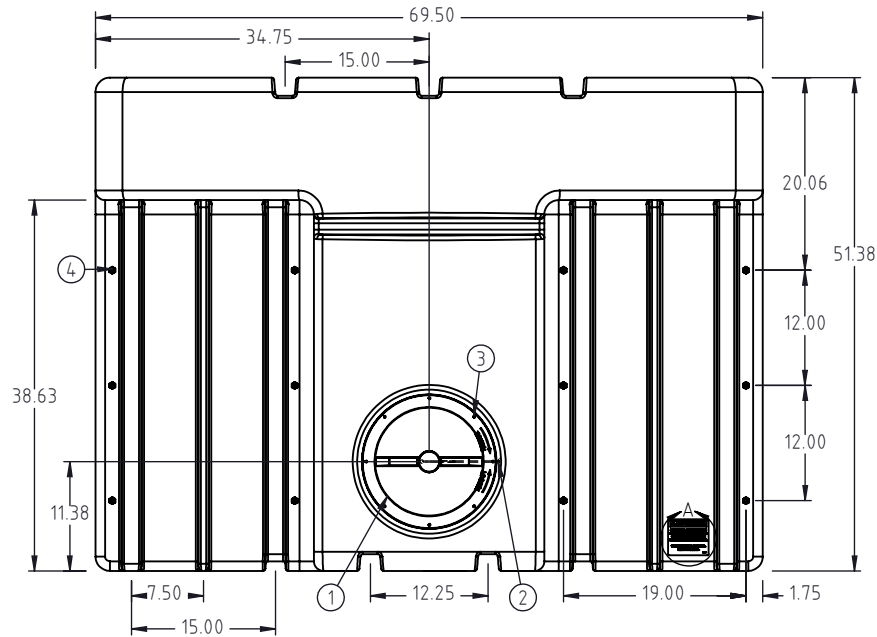

IMPORTANT:

USE ALL INSERTS AVAILABLE ON EACH SIDE OF TANK TO SECURE FRAMEWORK OR MOUNTING PLATE FOR ENGINE/PUMP AND HOSE REEL IF SO EQUIPPED.

TORQUE ALL BOLTS TO 12-15 FT. LBS. WITH LOCK WASHERS.

14728

DETAIL A
SCALE 1:2

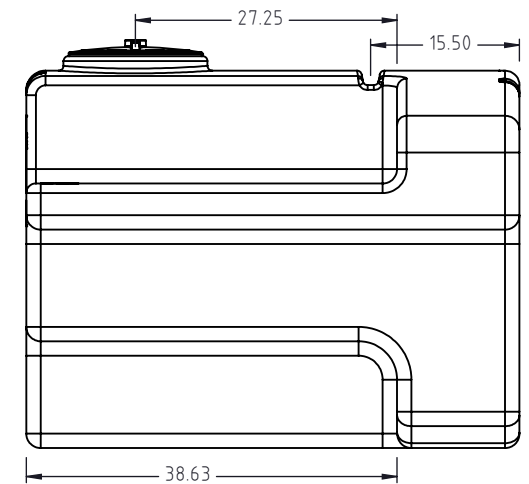
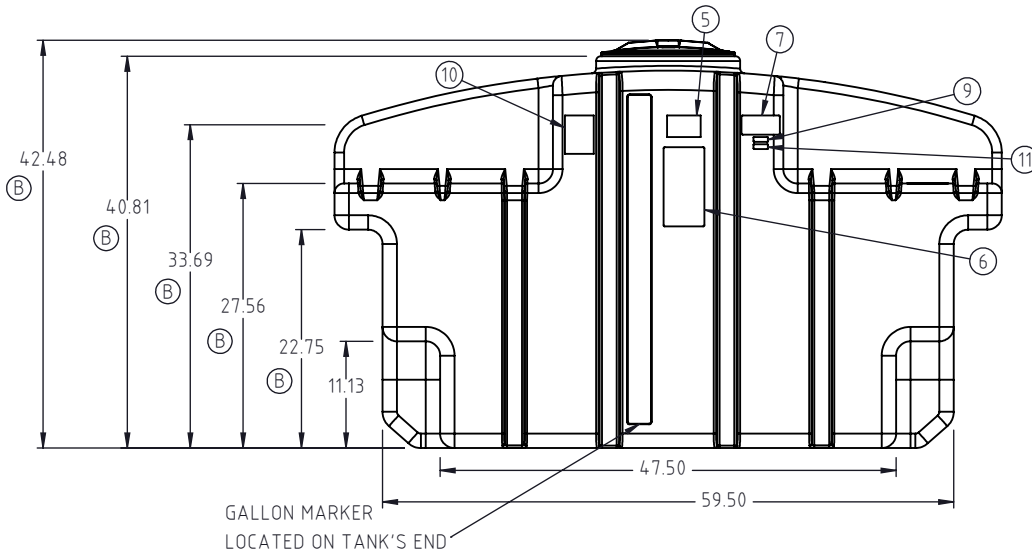

B	22.75 WAS 19.63, 27.56 WAS 26.25, 33.69 WAS 32.38, 40.81 WAS 39.50, 42.48 WAS 41.16.	ADH	9/13/2024	4644
A	14723 LABEL UPDATED	BES	7/10/2024	4614
REV.	DESCRIPTION	BY	DATE	CCN

DRAWN / DATE	MATERIAL :
ADH 8/18/2017	14575 1.7 MELT
APPRD. / DATE	
REH 8/18/2017	
SHOT WEIGHT: 200 LBS.	NOTES:
SHIPPING WEIGHT: 202 LBS.	1.) 0.345" WALL
FINISH:	



Den Hartog INDUSTRIES, INC.

Ace Roto-Mold • Injection Molding • Blow Molding • Sowjoy
4010 HOSPERS DRIVE S. BOX 425, HOSPERS, IOWA 51238-0425

DESCRIPTION		400 GALLON SPACE SAVER TANK	
SCALE	PART NO.	SHEET	
N.S.	SSPU0400-70	1 OF 1	

ALL DIMENSIONS ARE IN DECIMAL INCHES TOLERANCES UNLESS OTHERWISE SPECIFIED

THIRD ANGLE PROJECTION
ANSI 14.5M

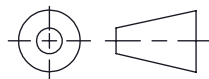

POLYETHYLENE
±1% @ 68°F

METAL
DECIMAL ± .125"
FRACTION ± 1/4"
ANGLE ± 1°