

© DEN HARTOG INDUSTRIES, INC.

Copyright. All information furnished within this document, electronic file or design correspondence is the property of Den Hartog Industries, Inc. and shall not be used, disclosed to others or copied without the expressed written consent of Den Hartog Industries, Inc.

ST024-LG

B

ITEM NO.	PART NUMBER	DESCRIPTION	QTY.
1	12615	LEG, 70/120 TOTE SKID-24"	4
2	12503	BOLT, 3/8" X 1" HEX	16 *
3	11094	WASHER, 3/8" X 1" OD FLAT SS	16 *
4	10223	NUT, 3/8" STAINLESS NYLOK	16 *
NS	ST024-LG	INSTRUCTIONS	1 * (A)

* INCLUDED IN HARDWARE BAG

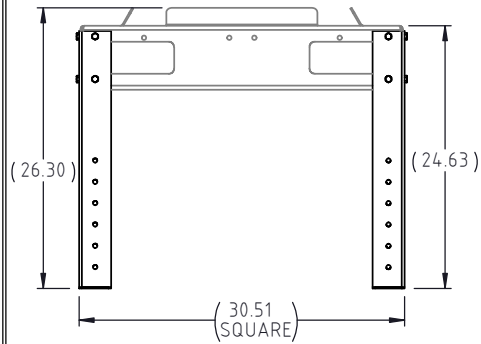

WARNING

- DO NOT STACK 120 GAL. TOTES OVER 2 HIGH ON STAND, (B)
- DO NOT STACK 70 GAL. TOTES OVER 3 HIGH ON STAND.
- DO NOT STACK 35 GAL. TOTES OVER 5 HIGH ON STAND.
- DO NOT USE STAND FOR TOTE TRANSPORT
- INSTALLATION OF THE STAND REQUIRES A LEVEL CONCRETE SURFACE.

MAXIMUM LOAD CAPACITY = 2300 LB.

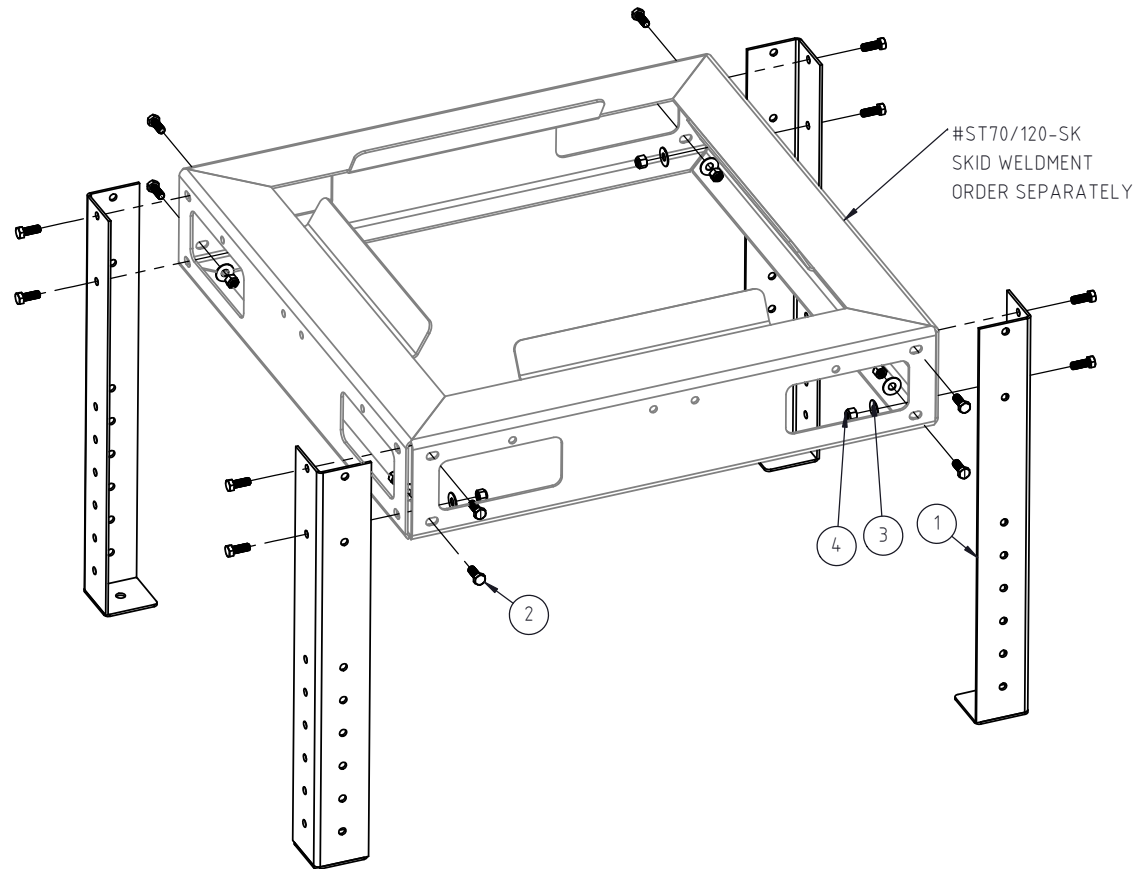

B	UPDATED PRINT, ADDED WEIGHT RATING INFO	SAS	11/9/2023	4530	DRAWN / DATE ADH 11/26/08	MATERIAL : SEE COMPONENTS
A	ST024-LG WAS ST70/120-LG	ADH	4/18/11	2207	APPRD. / DATE REH 1/6/09	
REV.	DESCRIPTION	BY	DATE	CCN	SHOT WEIGHT:	NOTES:
					SHIPPING WEIGHT: 24 LBS.	
					FINISH: POWDER COAT	



Den Hartog INDUSTRIES, INC.

Ace Roto-Mold • Injection Molding • Blow Molding • Sowjoy
4010 HOSPERS DRIVE S. BOX 425, HOSPERS, IOWA 51238-0425

DESCRIPTION		35, 70 AND 120 GALLON TOTE SKID LEG KIT	
SCALE	N.S.	PART NO.	(A) ST024-LG
		SHEET.	1 OF 1

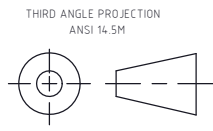

ALL DIMENSIONS ARE IN DECIMAL INCHES TOLERANCES UNLESS OTHERWISE SPECIFIED

POLYETHYLENE	METAL
±1% @ 68°F	DECIMAL ± .125" FRACTION ± 1/4" ANGLE ± 1°