

© DEN HARTOG INDUSTRIES, INC.

Copyright. All information furnished within this document, electronic file or design correspondence is the property of Den Hartog Industries, Inc. and shall not be used, disclosed to others or copied without the expressed written consent of Den Hartog Industries, Inc.

ITEM NO.	PART NUMBER	DESCRIPTION	QTY.
1	13223	36" TOTE SKID LEG WELDMENT	4
2	12503	BOLT, 3/8" X 1" SS	32 *
3	11094	WASHER, 3/8" X 1" OD FLAT SS	32 *
4	10223	NUT, 3/8" STAINLESS NYLOK	32 *
5	13224	LEG BRACE	8
6	ST036-LG	INSTRUCTIONS	1 *
NS	13225	CARTON	1

ST036-LG

* INCLUDED IN HARDWARE BAG

MAXIMUM LOAD CAPACITY = 2300 LB.

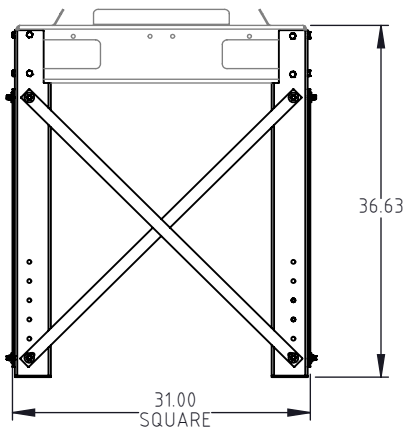

NOTE BRACE HOLE LOCATIONS

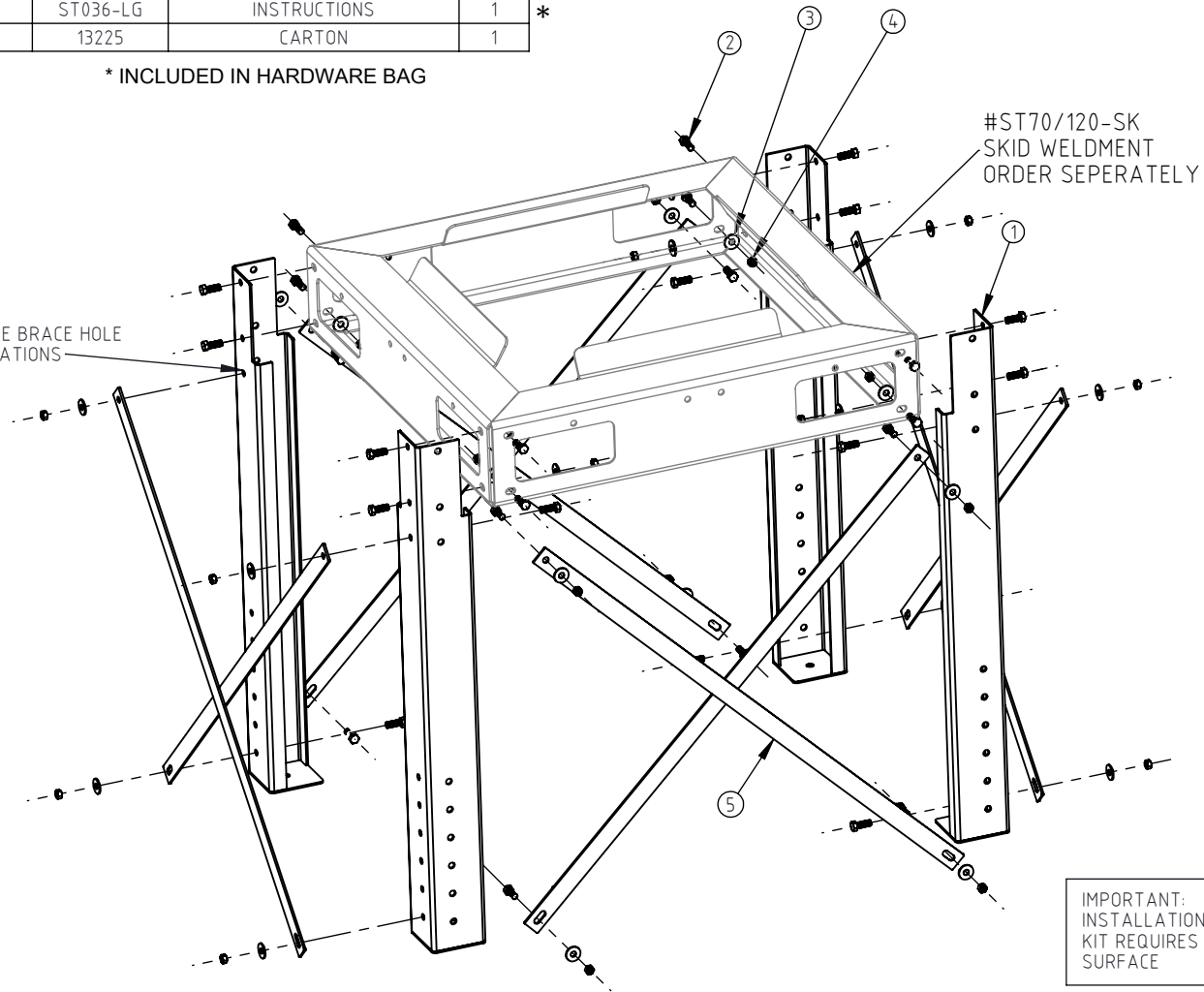

IMPORTANT:
INSTALLATION OF THIS LEG
KIT REQUIRES A LEVEL CONCRETE
SURFACE

REV	DESCRIPTION	BY / DATE	CCN	DRAWN / DATE ADH 4/8/11	MATERIAL
				APPROD. / DATE REH 4/18/11	
ALL DIMENSIONS ARE IN DECIMAL INCHES TOLERANCES UNLESS OTHERWISE SPECIFIED		THIRD ANGLE PROJECTION ANSI 14.5M		SHOT WEIGHT:	NOTES:
POLYETHYLENE ±1% @ 68°F		METAL DECIMAL ± .125" FRACTION ± 1/4" ANGLE ± 1°		SHIPPING WEIGHT: 70 LB.	PACKAGE IN 13225 CARTON FOR SHIPMENT.
		FINISH:			



Den Hartog
INDUSTRIES, INC.

Ace Roto-Mold Injection Molding Blow Molding Sowjoy

4010 HOSPERS DRIVE S. BOX 425, HOSPERS, IOWA 51238-0421

DESCRIPTION	70 AND 120 GALLON TOTE SKID LEG KIT-36 INCH	
SCALE	N.S.	PART NO. ST036-LG