

Copyright. All information furnished within this document, electronic file or design correspondence is the property of Den Hartog Industries, Inc. and shall not be used, disclosed to others or copied without the expressed written consent of Den Hartog Industries, Inc.

KEY	PART NUMBER	DESCRIPTION	QTY.
1	13460	DRIP TRAY BRACE	1
2	12618	DRIP TRAY	1
3	12634	SCREEN FOR DRIP TRAY	1
4	12503	BOLT, 3/8" X 1" HEX	4 *
5	11094	WASHER, 3/8" X 1" OD FLAT SS	4 *
6	10223	NUT, 3/8" STAINLESS NYLOK	4 *
7	12680	SCREW, #8 X 3/4" OVAL PHILLIPS	4 (A)
8	ST70-120-DT	INSTRUCTIONS	1 *

*=HARDWARE BAG

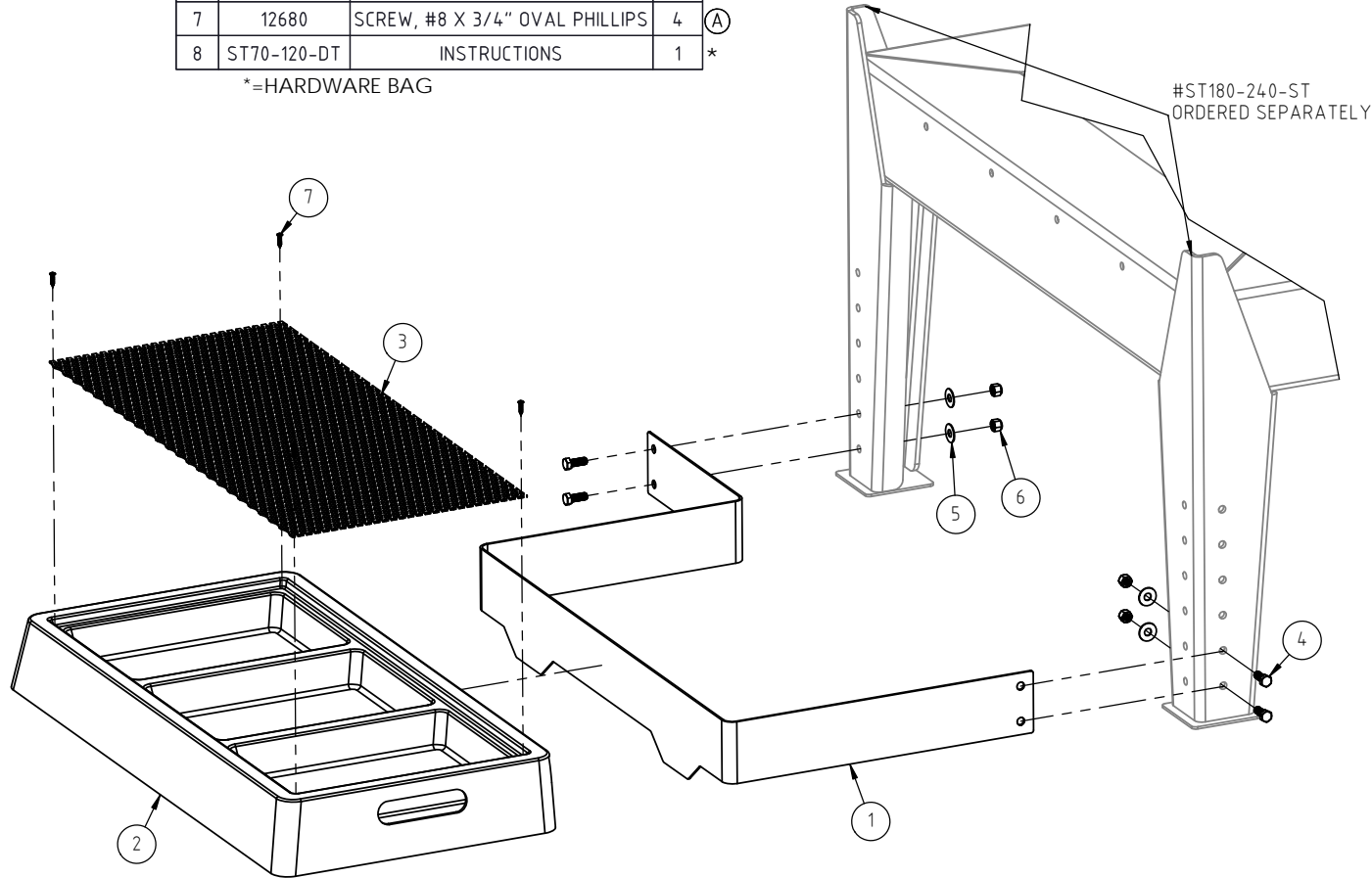

				DRAWN / DATE ADH 9/13/11	MATERIAL
A	12680 SCREWS ADDED TO THE PRINT.	ADH 7/30/18	3604	APPRD. / DATE REH 11/4/11	
REV	DESCRIPTION	BY / DATE	CCN		
ALL DIMENSIONS ARE IN DECIMAL INCHES TOLERANCES UNLESS OTHERWISE SPECIFIED		THIRD ANGLE PROJECTION ANSI 14.5M		SHOT WEIGHT:	NOTES:
POLYETHYLENE		METAL DECIMAL ± .125" FRACTION ± 1/4" ANGLE ± 1°		SHIPPING WEIGHT:	
±1% @ 68°F				FINISH:	



Den Hartog
INDUSTRIES, INC.

Ace Roto-Mold Injection Molding Blow Molding Sowjoy

4010 HOSPERS DRIVE S. BOX 425, HOSPERS, IOWA 51238-0421

DESCRIPTION 180 AND 240 GALLON TOTE DRIP TRAY ASSEMBLY

SCALE N.S.

PART NO. ST180/240-DT