

© DEN HARTOG INDUSTRIES, INC.

Copyright. All information furnished within this document, electronic file or design correspondence is the property of Den Hartog industries, Inc. and shall not be used, disclosed to others or copied without the expressed written consent of Den Hartog Industries, Inc.

| KEY | PART NUMBER | DESCRIPTION | QTY. |
|-----|-------------|----------------|------|
| 1 | 13494 | STAND, FRAME | 4 |
| 2 | 13458 | TOTE STAND LEG | 4 |
| 3 | 13459 | LEG PAD | 4 |
| 4 | 13461 | SUPPORT BEAM | 1 |

ST180-240-ST

A

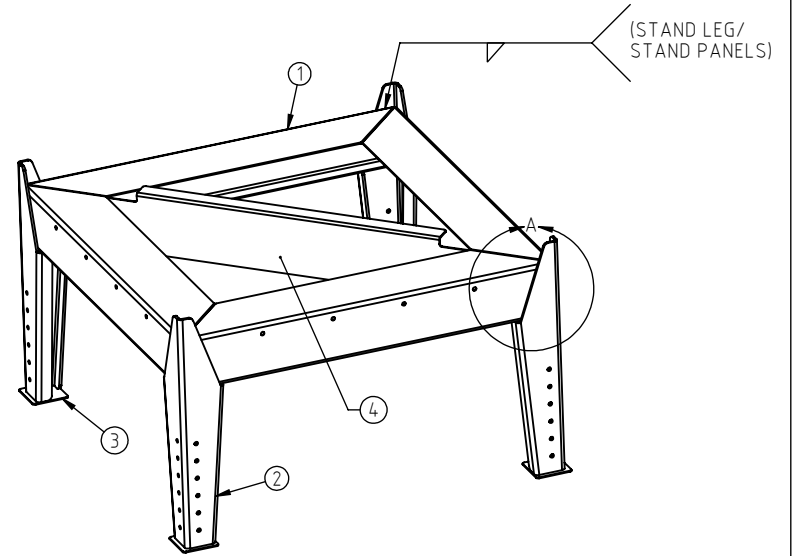
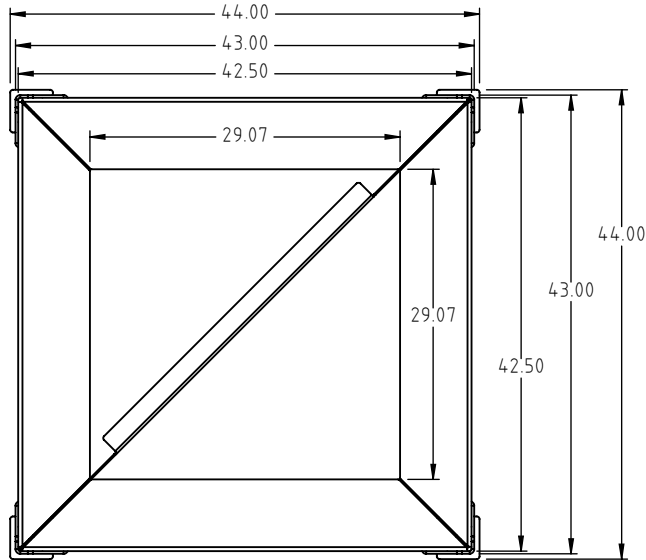

WARNING:

1. DO NOT STACK 240 or 180 GAL. TOTES (A) OVER 2 HIGH ON STAND,

2. DO NOT USE STAND FOR TOTE TRANSPORT

3. INSTALLATION OF THE STAND REQUIRES A LEVEL CONCRETE SURFACE.

MAXIMUM LOAD CAPACITY = 4500 LB.

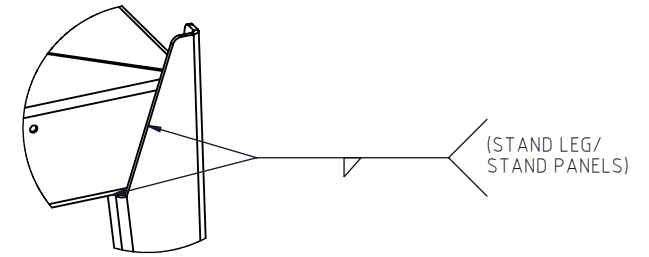
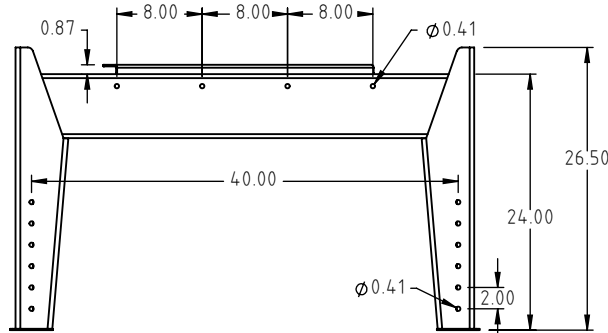

DETAIL A
SCALE 1 : 10

| | | | | | |
|--|---|--|------------------------------|---------------------------|------------------------------|
| DRAWN / DATE ADH 9/13/11 | | | MATERIAL : SEE COMPONENTS | | |
| A | UPDATED PRINT FORMAT, ADDED WEIGHT RATING INFORMATION | SAS | 11/9/2023 | 4530 | APPRD. / DATE REH 11/4/11 |
| REV. | DESCRIPTION | BY | DATE | CCN | |
| ALL DIMENSIONS ARE IN DECIMAL INCHES TOLERANCES UNLESS OTHERWISE SPECIFIED | | THIRD ANGLE PROJECTION ANSI 14.5M | | SHOT WEIGHT: | |
| POLYETHYLENE | | METAL | | SHIPPING WEIGHT: 175 LBS. | |
| ±1% @ 68° F | | DECIMAL ± .125" FRACTION ± 1/4" ANGLE ± 1° | | FINISH: BLACK POWDER COAT | |
| | | NOTES: | | | |



Den Hartog

INDUSTRIES, INC.

Ace Roto-Mold • Injection Molding • Blow Molding • Sowjoy
4010 HOSPERS DRIVE S. BOX 425, HOSPERS, IOWA 51238-0425

| | | |
|--|--------------------------|------------------|
| DESCRIPTION 180 AND 240 GALLON TOTE STAND | | |
| SCALE N.S. | PART NO. ST180-240-ST | SHEET. 1 OF 1 |