

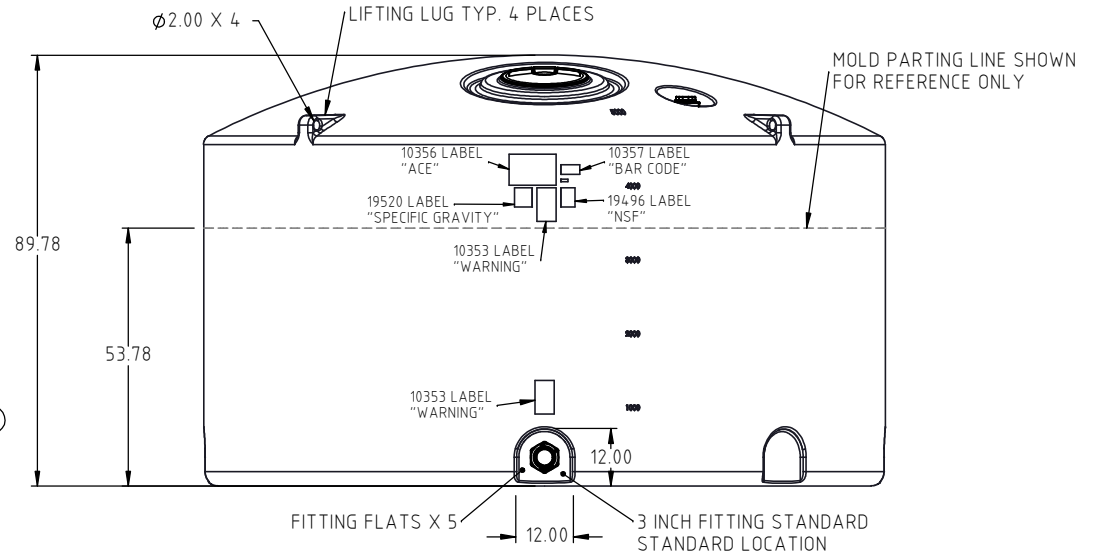

Copyright. All information furnished within this document, electronic file or design correspondence is the property of Den Hartog industries, Inc. and shall not be used, disclosed to others or copied without the expressed written consent of Den Hartog Industries, Inc.

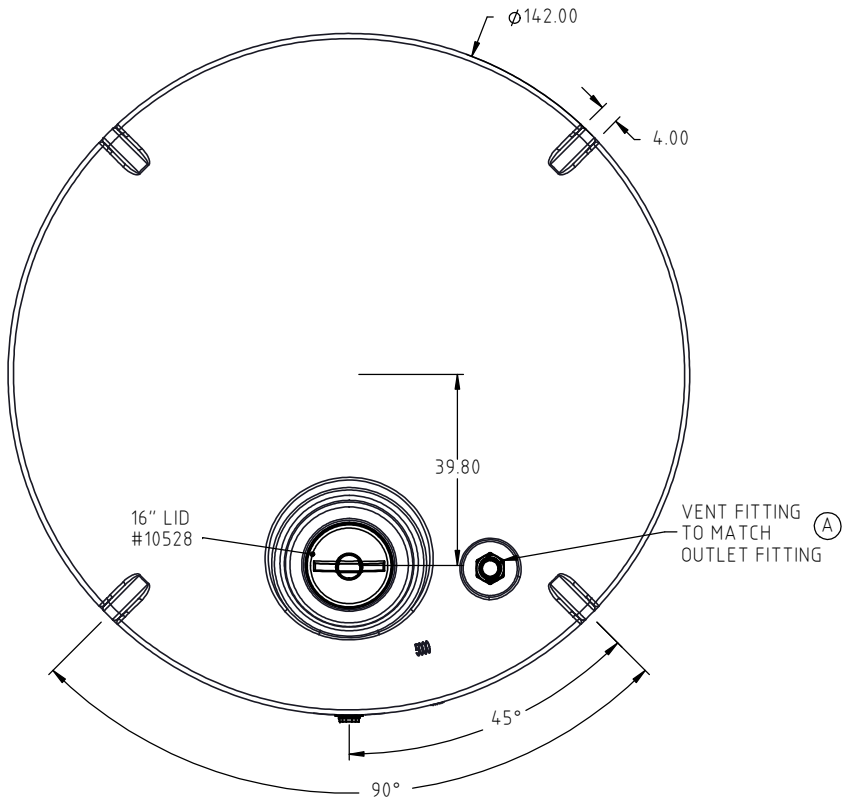

				DRAWN / DATE ADH 7/19/13	MATERIAL 10538 2 MELT
A	VENT LOCATION SHOWN ON PRINT	ADH 6/9/14	2860	APPROD. / DATE REH/7/31/13	
REV	DESCRIPTION	BY / DATE	CCN		
ALL DIMENSIONS ARE IN DECIMAL INCHES TOLERANCES UNLESS OTHERWISE SPECIFIED		THIRD ANGLE PROJECTION ANSI 14.5M		SHOT WEIGHT: 870.00 LBS S.G. 1.5 950.00 LBS S.G. 1.7	NOTES: 1.) WHITE, BLACK, OR YELLOW COLOR 2.) 15 SP = 0.45 WALL 1.7 SP = 0.53 WALL
POLYETHYLENE ±1% @ 68°F		METAL DECIMAL ± .125" FRACTION ± 1/4" ANGLE ± 1°		SHIPPING WEIGHT: 872.00 LBS S.G. 1.5 952.00 LBS S.G. 1.7	FINISH:



Den Hartog

INDUSTRIES, INC.

Ace Roto-Mold Injection Molding Blow Molding Sowjoy

4010 HOSPERS DRIVE S. BOX 425, HOSPERS, IOWA 51238-0425

DESCRIPTION VT4995 GALLON VERTICAL TANK WITH DOME TOP LID	
SCALE N.S.	PART NO. VT4995-142