

© DEN HARTOG INDUSTRIES, INC.

Copyright. All information furnished within this document, electronic file or design correspondence is the property of Den Hartog industries, Inc. and shall not be used, disclosed to others or copied without the expressed written consent of Den Hartog Industries, Inc.

VT8000-120

E

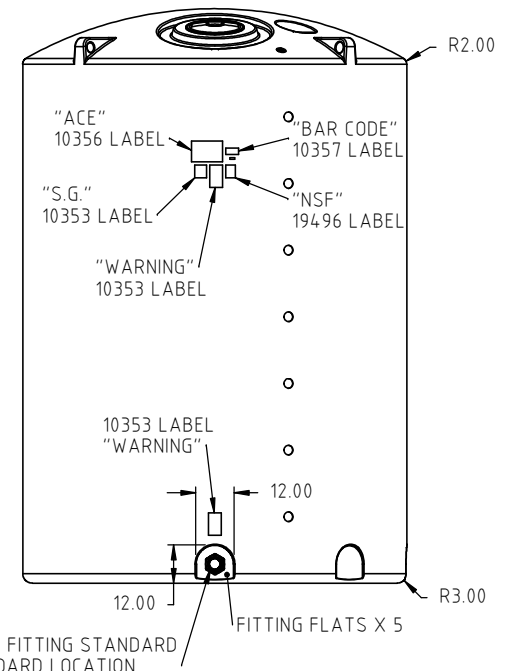
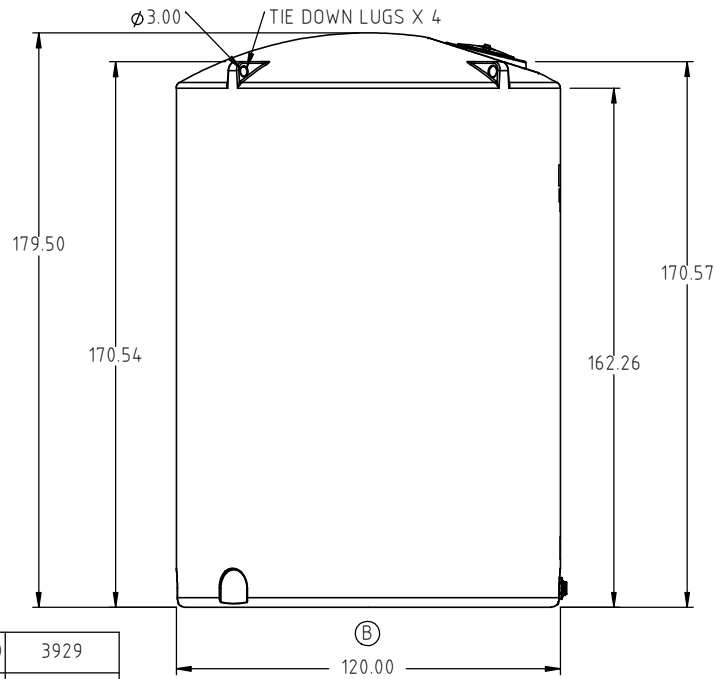
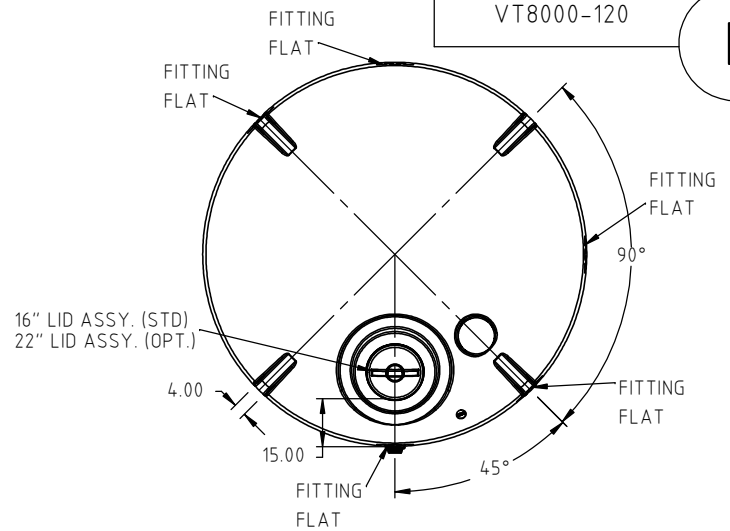
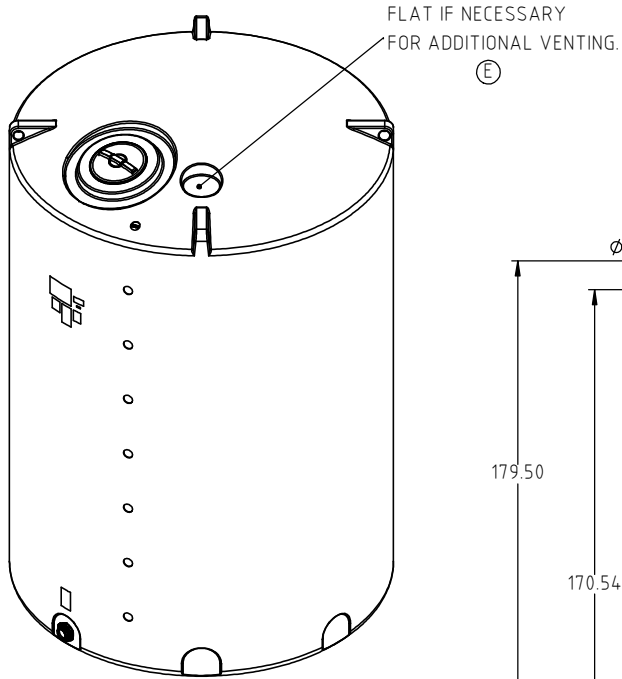

③ 3 INCH FITTING STANDARD STANDARD LOCATION

E	DETAILS OF THE FLAT FOR OPTIONAL VENTING CLARIFIED ON THE PRINT.	ADH 3/6/20	3929
D	PART REDRAWN FOR NEW MOLD	DHJ 2/8/17	3468
C	ADDED STANDARD FITTING AND LOCATION	DHJ 3/31/10	2013
B	CORRECT VIEW PERSPECTIVE. DRAWING TEMPLATE UPDATED. ADD THICKNESS.	DHJ 6/25/09	1895
A	CHANGE PART #	12/12/06	
REV	DESCRIPTION	BY / DATE	CCN

DRAWN / DATE	MATERIAL
DHJ 12/4/06	1.) 2 MELT POWDER 10538
APPRD. / DATE	
ADH 11/20/07	

ALL DIMENSIONS ARE IN DECIMAL INCHES TOLERANCES UNLESS OTHERWISE SPECIFIED

POLYETHYLENE METAL
 ±1% @ 68°F DECIMAL ± .125"
 FRACTION ± 1/4"
 ANGLE ± 1°

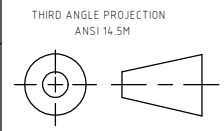

SHOT WEIGHT:	1930 LBS
SHIPPING WEIGHT:	1932 LBS
FINISH:	

NOTES: ③

1.) 1.03 WALL @ FLAT



Den Hartog
INDUSTRIES, INC.

Axa Roto-Mold Injection Molding Blow Molding Sowjoy

4010 HOSPERS DRIVE S. BOX 425, HOSPERS, IOWA 51238-0425

DESCRIPTION	8000 GALLON VERTICAL TANK	
SCALE	N.S.	PART NO. VT8000-120