

Copyright. All information furnished within this document, electronic file or design correspondence is the property of Den Hartog Industries, Inc. and shall not be used, disclosed to others or copied without the expressed written consent of Den Hartog Industries, Inc.

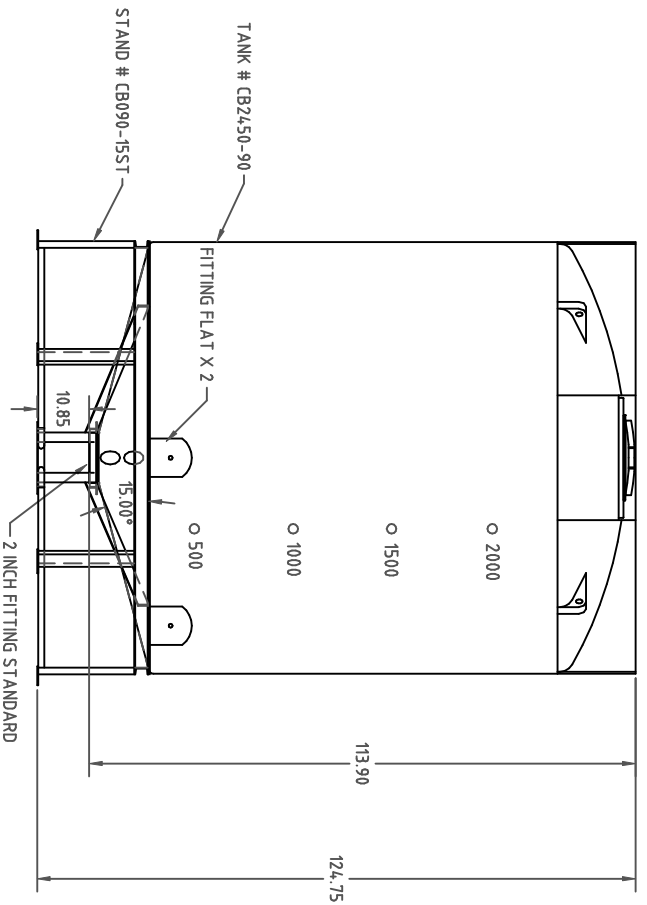

| | | | | | | | | | |
|-----|---|-----------|-----|------------------------------|---------------------------------------|--|---|-------|-------------------|
| REV | DESCRIPTION | BY / DATE | CCN | DRAWN / DATE | MATERIAL | NOTES: | DESCRIPTION | SCALE | PART NO. |
| | ALL DIMENSIONS ARE IN DECIMAL INCHES TOLERANCES UNLESS OTHERWISE SPECIFIED | | | DHJ 3/9/11 | TANK 10420 POLYETHYLENE | 1. THICKNESS @ BOTTOM SIDEWALL .390 | 2450 GAL. 90" DIA. X 15° CONE BOTTOM TANK W/ INDUSTRIAL TOP AND STAND | N.S. | CB2450-90+90-15ST |
| | POLYETHYLENE | | | APPRD. / DATE | STAND MILD STEEL BLACK POWDER COAT | | | | |
| | | | | REH 3/10/11 | | | | | |
| | | | | SHOT WEIGHT: | | | | | |
| | | | | SHIPPING WEIGHT: 817 LBS. | | | | | |
| | | | | FINISH: | | | | | |
| | | | | | | | | | |
| | | | | | | | | | |

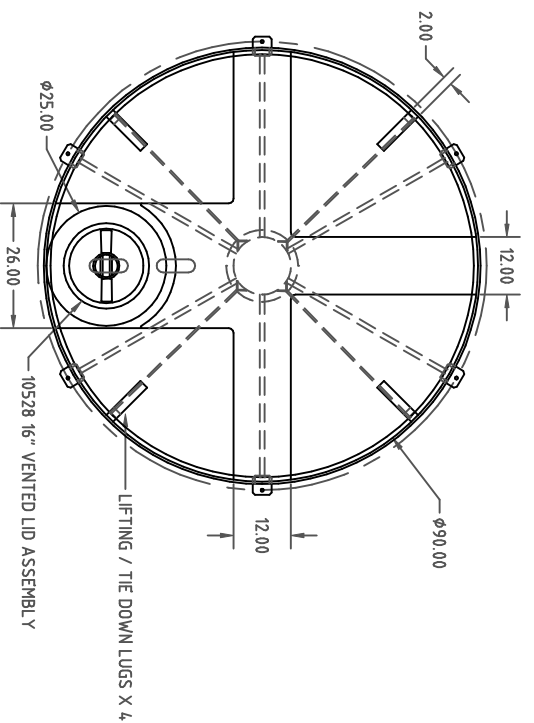

Den Hartog

INDUSTRIES, INC.

Ace Roto-Mold Injection Molding Blow Molding Saw-Joy

4010 HOSPERS DRIVE S. BOX 425, HOSPERS, IOWA 51238-0425

±1% @ 68 ° F
DECIMAL ± .125"
FRACTION 1/4"
ANGLE ± 1°

