

Ace Roto-Mold

PRODUCT RELEASE

OP1200-RT 1200 Gallon Containment Tank

Product is a rectangular 1200 gallon secondary containment tank for indoor or outdoor stationary applications. Tank is designed for the containment of all chemicals rated for contact with polyethylene.



FEATURES:

- Manufactured from rotationally molded polyethylene with U.V. stabilizers.
- Standard weight tank is designed for use with chemicals with a specific gravity of 1.7.
- Standard color is natural and is an FDA compliant material.
- Tank features a double wall rim around the top for strength.
- Tanks nest together for transport and storage.
- Nesting lugs are provided in each corner and sides to prevent wedging.

SPECIFICATIONS:

Overall Dimensions: 102" wide x 116" long x 29" tall

Weight of tank: 325 lbs.

 **Den Hartog**
INDUSTRIES, INC.
"Always at Your Service"



Warning: Cancer and Reproductive Harm.
www.p65Warnings.ca.gov

Ph: 800-342-3408
Fax: 712-752-8222

www.denhartogindustries.com
sales@denhartogindustries.com

4010 Hospers Dr. South
Hospers, IA 51238

Copyright. All information furnished within this document, electronic file or design correspondence is the property of Den Hartog Industries, Inc. and shall not be used, disclosed to others or copied without the expressed written consent of Den Hartog Industries, Inc.

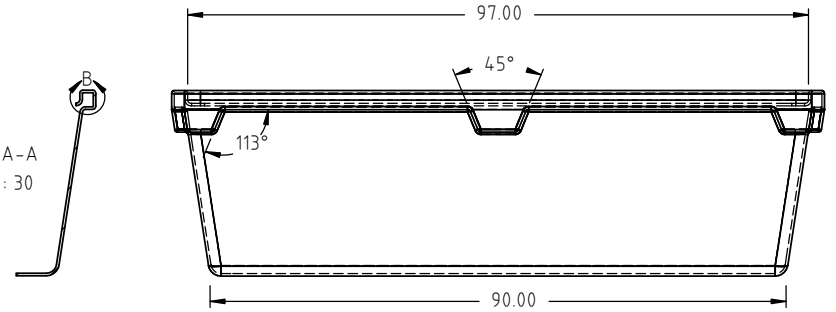
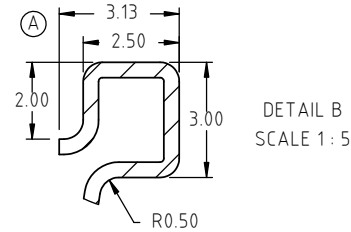
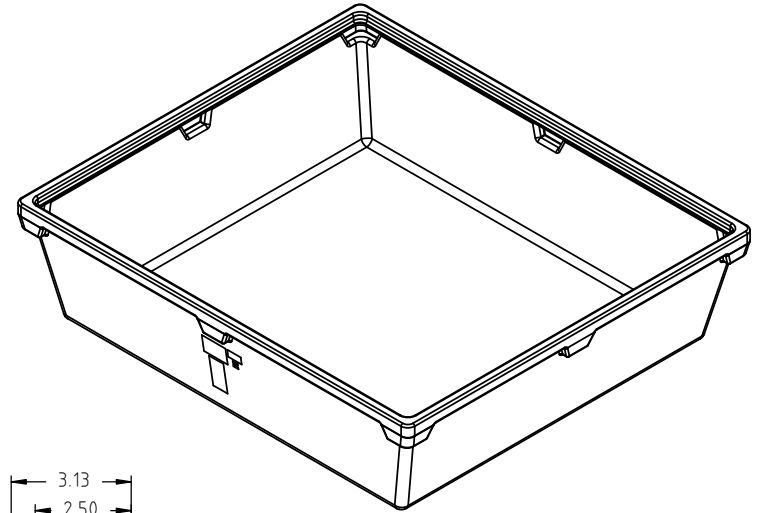
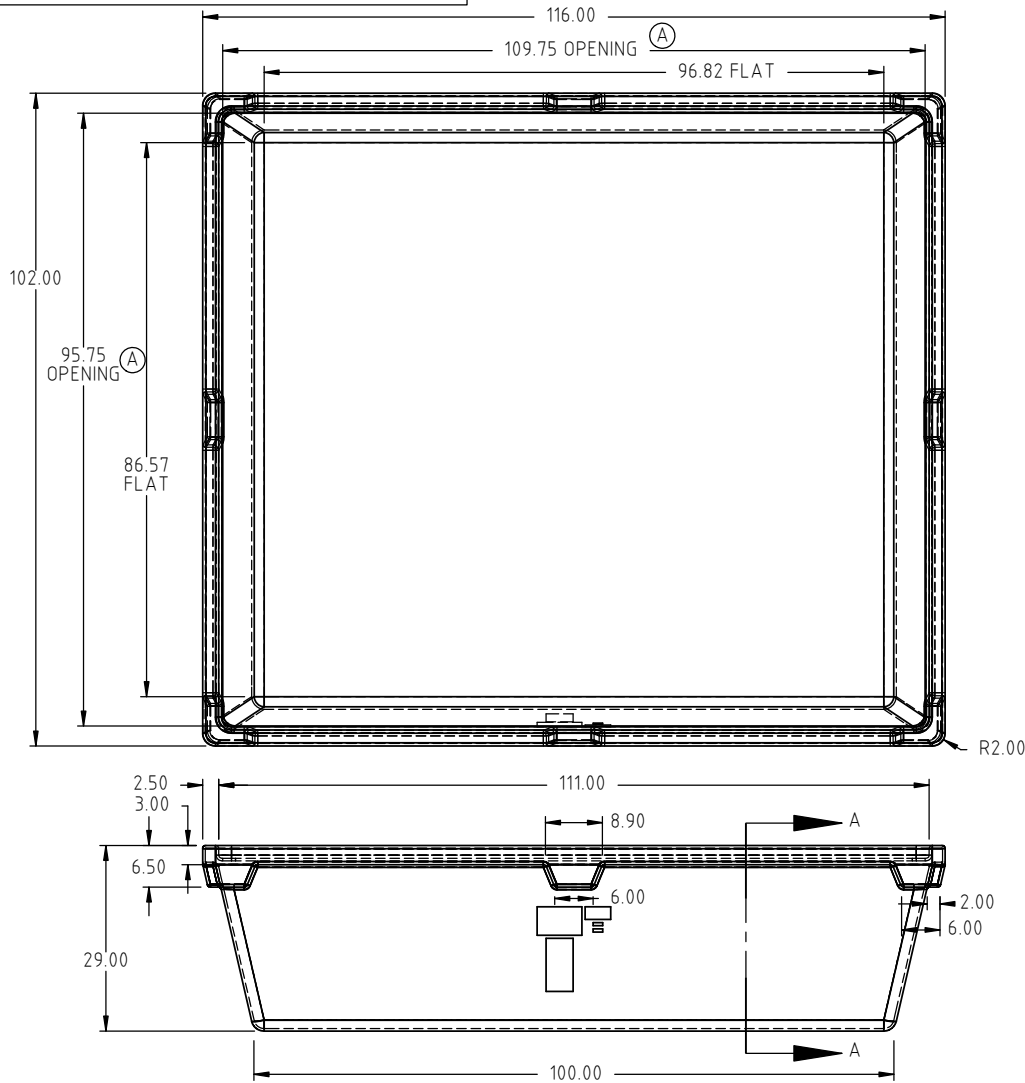

				DRAWN / DATE ADH 1/31/19	MATERIAL 10538 2 MELT NATURAL RESIN.
A	365 WAS 340. 325 WAS 330. 578" OFFSET WAS 1/4"	ADH 11/22/19	3891	APPRD. / DATE REH 3/4/19	
REV	DESCRIPTION	BY / DATE	CCN		
ALL DIMENSIONS ARE IN DECIMAL INCHES TOLERANCES UNLESS OTHERWISE SPECIFIED		THIRD ANGLE PROJECTION ANSI 14.5M		SHOT WEIGHT: 365 LBS.	NOTES: 1.) 0.40 NOM. WALL THICKNESS.
POLYETHYLENE		MATERIAL DECIMAL ± .125" FRACTION ± 1/4" ANGLE ± 1°		SHIPPING WEIGHT: 325 LBS.	
±1% @ 68°F		FINISH: NONE			



Den Hartog
INDUSTRIES, INC.

Ace Roto-Mold Injection Molding Blow Molding Sowjoy

4010 HOSPERS DRIVE S. BOX 425, HOSPERS, IOWA 51238-0425

DESCRIPTION 1200 GALLON CONTAINMENT TANK	
SCALE N.S.	PART NO. OP1200-RT