

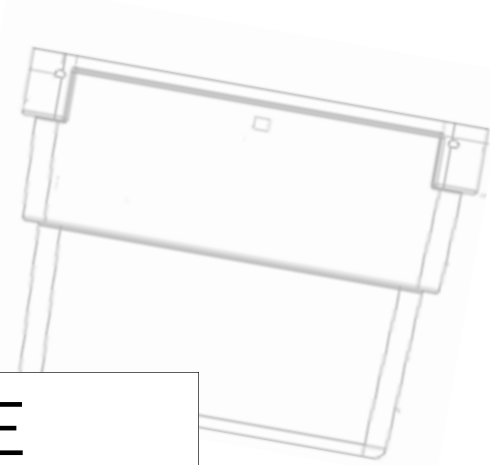

Den Hartog
INDUSTRIES, INC.

Technical Guide

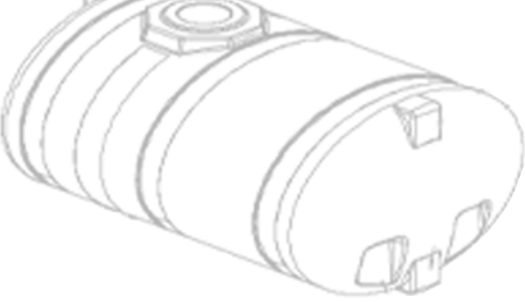



TECHNICAL GUIDE TABLE OF CONTENTS

	PAGE
ASTM Standard Letter	1
Algae Information Letter	2
Biodiesel Statement	3
Diesel Exhaust Fluid Statement	4
CARB Regulations Statement	5
Santoprene vs EPDM Gaskets	6
Santoprene Chemical Resistance	7-8
Chemical Compatibility for Chlorine	9
Frequently Asked Questions	10-17
Chemical Resistance Data Chart	18-20
Polyethylene Tank Anchor Design	21-22
Tank Date Stamp Locations	23-26
Truckload Capacities	27-29
Tank Shipping/Pallet Options	30-46

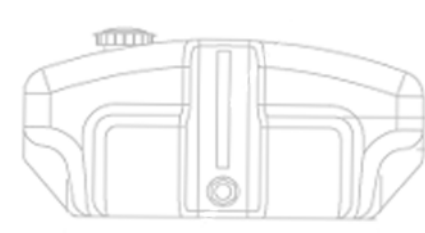
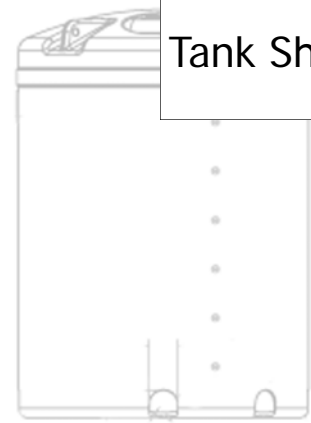
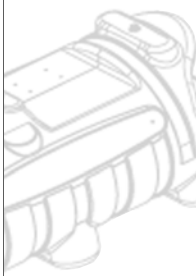



Den Hartog
INDUSTRIES, INC

ACE ROTO-MOLD • INJECTION MOLDING • BLOW MOLDING • SOWJOY

"Always At Your Service"

August 29, 2011

To Whom It May Concern:

This letter is to inform you that our polyethylene tanks are designed in accordance with ASTM D1998-06 Standards. All materials utilized in the production of our tanks are virgin grade only, have the maximum available U.V. additives and are shipped to us with a certificate of analysis to insure compliance with established properties.

Sincerely Yours,

Robert E. Hardy
Director of Engineering



ACE ROTO-MOLD • INJECTION MOLDING • BLOW MOLDING • SOWJOY

"Always At Your Service"

Information regarding Algae formation in polyethylene storage tanks

Algae (attachment A) are photosynthetic organisms (attachment B) whose formation in water storage tanks is dependent, primarily, upon the presence of light energy and moisture. Since water tanks have the moisture present, the amount of exposure to light energy is critical to prevent Algae growth.

Therefore the transmission of light energy through the polyethylene tank walls to sustain photosynthesis must be eliminated. This is done by adding pigment to the polyethylene at the time of manufacture.

Black colored tanks are the most efficient in preventing light transmission, as only a small amount of pigment is required to eliminate the natural translucence of the polyethylene. Other colors, if highly concentrated, can also eliminate translucence but can severely weaken the tank since the pigment is technically a contaminate when introduced into polyethylene.

Although natural colored polyethylene tanks transmit the most amount of light energy, tanks that are tinted (with the exception of black) will typically provide enough light energy to sustain photosynthesis and promote Algae growth.

Therefore it cannot be stated that all tinted or colored tanks do not promote Algae unless the amount of light energy transmission is properly evaluated. Any amount of light energy will allow Algae formation.

Robert E. Hardy
Director of Engineering



Den Hartog
INDUSTRIES, INC

ACE ROTO-MOLD • INJECTION MOLDING • BLOW MOLDING • SOWJOY

"Always At Your Service"

June 10, 2010

To whom it may concern;

Den Hartog Industries Inc. policy regarding the storage of Biodiesel products in pure (B100) formulation shall be as follows:

1. Only ASTM designed tanks are recommended
2. Only above ground storage is permitted.
3. Only 1.9 or greater specific gravity tank weights shall be utilized.
4. Use Viton gaskets in all fittings.
5. Secondary containment shall be provided for all installations and shall be in accordance with all applicable state and local codes.

A one-year limited warranty from the date of manufacture will apply to tanks storing Biodiesel B100 and when in compliance with the above restrictions.

At this time Den Hartog Industries Inc. has no recommendation for the storage of Biodiesel blends (B%/%) at this time.

Sincerely,

Robert E. Hardy
Director of Engineering



Den Hartog
INDUSTRIES, INC

ACE ROTO-MOLD • INJECTION MOLDING • BLOW MOLDING • SOWJOY

"Always At Your Service"

March 2, 2011

To Whom It May Concern:

NOx Abatement in Diesel Engines Using SCR Technology

DHI Application Information

Effective January, 2010 the EPA will implement regulations affecting diesel engines manufactured for use in the USA. This regulation requires the use of SCR (Selective Catalytic Reduction) technology and introduces DEF (Diesel Exhaust Fluid) in to the exhaust gases to meet the EPA requirement for NOx levels. This regulation will be applicable to all diesel-powered products.

DEF is a chemical solution consisting of 32.5% + or – 0.7% of chemically pure urea mixed with deionized water and has been classified as a non-hazardous chemical.

DHI offers effective storage solutions for DEF with our broad line of polyethylene tanks.

The following specifications apply to all DHI tank products:

- 1.
2. Vertical Tanks are designed in accordance with ASTM D-1998 standards and are in compliance with ISO 22241-3, section 4.1.2. Tanks available for transportable applications are designed according to established engineering practices and tested. Only virgin polyethylene is utilized with densities ranging from .938 to .944 depending upon the size of tank. Standard specific gravities are 1.6 to 2.0 depending upon tank size and configuration specified. Other specific gravities are available upon request.
3. Lids are manufactured from high-grade injection molded polypropylene.
4. Fittings are available in high-grade injection molded polypropylene or machined type 316 stainless steel. Gaskets are available in Santoprene or EPDM.
5. Installation – reference the DHI Applications Guideline Manual for recommendations regarding handling, installation, plumbing, venting and site requirements.
6. DEF temperature exposure should be limited to between 15°F to 85°F to prevent freezing or loss of properties.

Sincerely Yours,

Robert E. Hardy



Den Hartog
INDUSTRIES, INC

ACE ROTO-MOLD • INJECTION MOLDING • BLOW MOLDING • SOWJOY

"Always At Your Service"

To whom it may concern:

Den Hartog Industries Inc. utilizes the Petro Seal system from Arkema to meet CARB/EPA fuel permeation regulations for fuel tanks. This material is covered under executive order C-U-05-005.



Robert E. Hardy
Director of Engineering

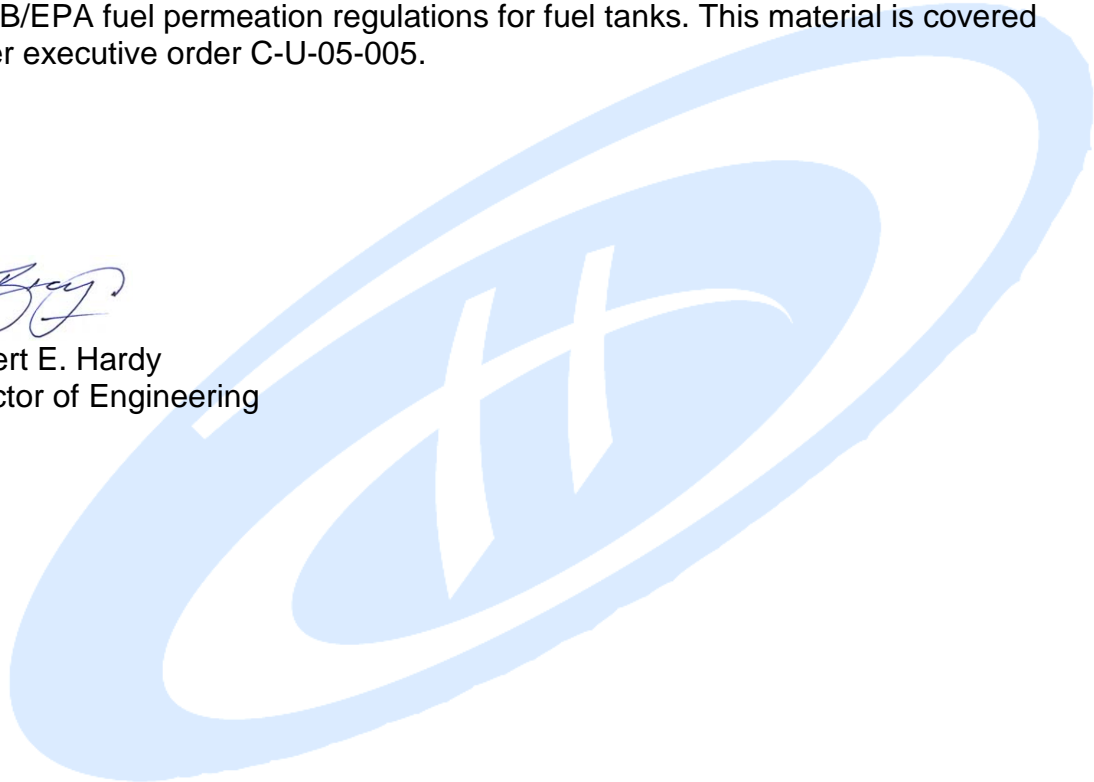



Den Hartog
INDUSTRIES, INC

ACE ROTO-MOLD • INJECTION MOLDING • BLOW MOLDING • SOWJOY

"Always At Your Service"

Santoprene vs EPDM Gaskets

Santoprene is a vulcanized rubber material that processes like a thermoplastic that runs in Den Hartog Industries Inc. injection presses.

Santoprene advantages – Santoprene has similar properties to EPDM. In fact, Santoprene is made from a derivative of EPDM. Santoprene's environmental aging resistance and liquid resistance are the same as EPDM. But beyond that, you will find that Santoprene is superior in regards to performance and cost. Parts made from Santoprene offer excellent heat aging, providing outstanding durability. Santoprene also has excellent resistance to cut growth while flexing, high tear strength and superior resistance to fatigue. Please reference the attached list of chemicals that Santoprene shows resistance to, and that list is the same as an EPDM list.

In terms of quality, Ace Roto-Mold has never had a tank returned or problem reported where our gasket failed when an EPDM gasket would have worked. Our gaskets have never failed when used with chemicals they are meant to be resistant to.

Robert E. Hardy
Director of Engineering



Santoprene Chemical Resistance:

Santoprene is a thermoplastic rubber designed to offer chemical resistance equivalent to neoprene. It is resistant to a wide variety of solvents and chemicals. It is not readily soluble in common solvents but will swell in aromatic solvents and halogenated organic solvents.

High polar fluids such as alcohols, ketones, glycols, esters, and aqueous solutions of acids, salts, and bases have little effect upon Santoprene rubber. Weight changes in these fluids are less than 10%, and physical property changes are minimal.

Little or No Effect on Santoprene

Acetaldehyde	Chloroacetic acid	Linseed Oil	Potassium salts
Acetic acid	Chronic acid	Magnesium salt	Silver salts
Acetic Anhydride	Chromium salts	Maleic acid	Soap solutions
Acrylonitrile	Copper salts	Manganese salts	Sodium salts
Aluminum Chloride	Ethylene glycol	Mercury salts	Sodium hydroxide
Aluminum sulfate	Ferric salts	Methanol	Sodium hypochlorite
Ammonia	Fluoborate salts	Natural gas	Stearic acid
Ammonium salts	Fluoboric acid	Nickel salts	Sulfur dioxide
Ammonium hydroxide	Fluosilicic acid	Nitric acid-10%	Sulfuric acid, dil.
Amyl acetate	Formaldehyde	Nitroethane	Sulfurous acid
Antimony salts	Formamide	Nitrogen oxides	Tannic acid
Arsenic salts	Formic acid	Nitrous acid	Tanning extracts
Barium salts	Glucose	Oils, animal	Trisodium phosphate
Benzoic acid	Glycerins	Oils. mineral	Urea
Bleaching liquor	Hydrochloric acid	Oils. vegetable	Uric acid
Boric acid	Hydrocyanic acid	Oxalic acid	Water
Bromine	Hydrogen peroxide	Oxygen	Water (brine)
Butyric acid	Hydrogen sulfide	Phosphoric acid	Water (stoam)
Calcium salts	Iodine and solutions	Phthalic acid	Zinc salts
Carbon Dioxide	Lactic acid	Phosphoric acid	
Chlorine (wet/dry)	Lead salts	Plating solutions	



Den Hartog
INDUSTRIES, INC

ACE ROTO-MOLD • INJECTION MOLDING • BLOW MOLDING • SOWJOY

"Always At Your Service"

Minor Effect

Acetates	Butane	Me Et Ketone	Skydrol 500-B4
Acetone	Butanol	Nitric acid-30%	Sulfuric acid-90%
Alcohols	Essential Oils	Nitrobenzene	Tetrahydrofuran
Amyl alcohol	Ethers	Oleic acid	Turpentine
Aniline	Ethanol	Phenol	
Benzaldehyde	Furfural	Propanol	
Benzyl alcohol	Lithium grease	Pyridine	

Severe Effect-NOT Recommended

Benzene	Cyclohexane	Kerosene	Nitric acid- 70%
Carbon tetrachloride	Ethyl chloride	Trichloroethylene	Perchloroethylene
Chlorobenzene	Freon	Lacquer	Toluene
Chloroform	Gasoline, unleaded	Naphtha	Xylene



Chemical Compatibility for Chlorine

Following are our recommendations based on current information:

Chemical	Concentration, %	Temperature of use, °C	Comments
Sodium hypochlorite	Less than 12%	23 (73° F)	Suitable under normal use conditions.
	Less than 12%	40 (104° F)	Some attack. Have seen 2 mil of surface erosion over reportedly 2-year period, which has weakened the tank. Would give it only a 5 out of 10 rating where 10 is best and 0 is the worst.
	12-16.5%	23 (73° F)	Suitable under normal use conditions.
	12-16.5%	40 (104° F)	Unsuitable
	Above 16.5%	23 (73° F) and 40 (104° F)	Unsuitable.
Sodium hydroxide (caustic soda)	35% or less	23 (73° F) and 40 (104° F)	Suitable under normal use conditions.
	50% or above	23 (73° F)	Not without testing
	50% or above	37 (99° F)	Unsuitable
Sodium chlorite	30%	23 (73° F) and 40 (104° F)	Suitable assuming normal use conditions.
	50%	23 (73° F)	Suitable. Rating of 8.
	50%	40 (104° F)	Not without testing.

Additional recommendations:

- Room temperature is assumed at 23° C (73° F)
- Non-controlled temperature is assumed at 40° C (104° F).
- PVC or CPVC (schedule 80) fittings with viton gaskets are required.
- Use of flexible connectors with fittings is also required.
- Secondary containment according to local regulations is recommended.
- We recommend opaque white or light color tanks.
- Use a 1.9 specific gravity rating on tanks larger than 1,000 gallons.
- An 18 month limited warranty applies to tanks storing Chlorine when in compliance with the above restrictions.

What chemicals can I store in your tanks?

Identify the chemical(s) to be stored in the tanks. Be certain to obtain a Certificate of Composition, MSDS (Material Safety Data Sheet) or other data from the chemical supplier so that the actual chemical compounds can be identified properly to evaluate the effect of the chemical on polyethylene storage containers. Be sure to check that the tank, fittings and fitting gasket material are compatible with the chemicals to be contained and the anticipated storage temperatures. Review the Chemical Resistance Data Chart on page 15. This will determine if the chemical to be stored is compatible with polyethylene. If this resistance data does not list the chemical you intend to store in the tank, contact the chemical manufacturer for recommendations regarding storage in polyethylene tanks.

What materials are used to manufacture your poly tanks?

Ace Roto-Mold tanks are offered in medium and high density polyethylene. The polyethylene utilized in the manufacture of Ace Roto-Mold poly tanks depends upon the size of the tank. There are minimal differences in the characteristics between medium and high density polyethylene. High density polyethylene offers a slightly higher density, chemical resistance and impact resistance than medium density polyethylene. Vertical tanks 3100 gallons and larger, Cone Bottom tanks 4600 gallons and larger, all Septic and Cistern tanks, all Crop Care tanks, as well as 2350, 2750 and 3250 gallon Free Standing Leg tanks are all made standard in high-density polyethylene. Please note that all Ace Roto-Mold tanks are available in high density polyethylene if requested.

How heavy a material can polyethylene tanks hold?

Ace Roto-Mold standard tanks have a specific gravity of 1.7. Our vertical tanks ranging from 20-625 gallons are standard with a specific gravity of 2.0. Specific gravity is the ratio of the chemical weight per gallon divided by the weight of water per gallon (8.33 lb per gallon). As an example, if a chemical weighs 10 lb per gallon, the specific gravity of the chemical is $10.0/8.33 = 1.2$ SG. (Metric: kilogram/cubic meter or gram/liter) Substances with a specific gravity greater than 1.0 are heavier than water, those with a specific gravity of less than 1.0 are lighter than water.

What is the wall thickness of your tanks?

Wall thickness varies from the top to the bottom of the tank. Our tanks 2000 gallons or smaller tend to have an even wall thickness due to the roto-molding process. Ace Roto-Mold standard tanks have a specific gravity of 1.7. We use the right amount of material and resin grades in order to insure that specific gravity is reached. We do provide wall thickness maps for our vertical tanks 5000 gallons and up as well as our cone bottom tanks 4600 gallons and up. Please consult the factory regarding these maps.

What are drill points on your tanks?

Drill points are a molded in feature of a tank used as a quick locating point for fittings. Drill points are typically located in standard fitting locations only. They appear as an indentation and are typically ¼” in diameter but may be even bigger in large tanks. They are often mistaken as a partially drilled hole. Even though the drill point is indented, the wall thickness is compensated for on the inside wall of the tank during the molding process. I.E., if you were able to run your hand over the inside wall where the drill point is located, you would feel a bump that would be comparable in height to the indentation on the outside. The only time drill points are visible is when tanks are ordered with no fittings or with fittings installed in non-standard locations.

What are witness lines in tanks?

Witness lines are what appear to be cracks in the finished product. These are caused when a crack develops in the mold; typically in radiuses where the mold experiences the greatest amount of stress. When this crack goes undetected, it tends to open up during the molding process due to heat which allows molten plastic to seep into the crack. Upon close inspection after the product is demolded, the witness line is a mirror image of the crack in the mold. If you were to run your fingernail across the witness line you would feel that the plastic is protruding rather than indenting. In fact, this witness line is able to be scraped away leaving a solid wall of plastic. This defect is cosmetic only and does not affect the integrity of the product in any way.

Is there UV protection in the resin you use?

Ace Roto-Mold tanks are molded from polyethylene compounded with the latest technology in ultraviolet (UV) light stabilizers. The UV stabilizers will reduce the harmful effects of ultraviolet light exposure and are intended to extend the life of a tank over similar materials that are not compounded with stabilizers. Our UV rating is “15” on most product materials which generally means that after 15,000 hours of exposure to the sun, there will be 50% of UV protection remaining. This rating also needs to consider location and prolonged exposure to the sun. Consult the factory for the specific UV rating of the product you are using.

Do your tanks have a UL rating?

UL 94 groups materials into categories based on their flammability. The polyethylene we use has undergone the horizontal flame test and has a UL94HB rating which means that specimens must not have a burn rate greater than 1.5 inches/minute for thickness between .120 and .500 inches and 3 inches/minute for a thickness less than .120 inches. Specimens must stop burning before the flame reaches the 4 inch mark.

Are your above ground tanks NSF approved?

National Sanitary Foundation (NSF) compliance considers a number of factors for approval. Among these are material and final configuration of the product including fittings and accessories that are exposed to the chemical. For this reason, please consult the factory regarding NSF approval.

Do your tanks contain any BPA's?

Our tanks are made from polyethylene. Bisphenol A (BPA) is not used as a component in the manufacture of polyethylene. BPA is primarily used in polycarbonate and in epoxies used to line cans. Polyethylene does not leach chemicals and has been used for direct food contact for many years.

How much additional capacity does the Dualline™ Tanks, containment tank, have?

All outer/containment tanks have a minimum of 10% over capacity of the main tank as is the required standard.

Can a SS bolt-in 2" Fitting be installed instead of the polypropylene fitting in the Dualline™ tanks?

There are different fitting options for the tanks, please contact Customer Service for a specific request.

Is it possible to install more than one fitting on the sidewall of a Dualline™ tank?

No, multiple fittings will not be allowed on the tanks sidewall. Additional fittings can be installed on the top of tank for draw out of the top.

Is the service fitting required on the Dualline™ tanks?

The service fitting is optional on the tanks.

Does the color of a tank give any indication as to the quality of the tank?

Ace Roto-Mold tanks are manufactured from polyethylene compounded with ultraviolet (UV) stabilizers. These UV stabilizers will reduce the harmful effects of ultraviolet light exposure and are intended to extend the life of a tank over similar materials that are not compounded with stabilizers. The standard color for most Ace Roto-Mold tanks is natural (translucent white). All tanks may be ordered in non-standard colors such as yellow, black, green or blue as an option. The color of the tank does not increase the life expectancy or UV resistance of a tank. Please note however, that the color may have an effect on FDA compliance.

Does the color of a tank have an impact on Algae growth?

Black colored tanks are the most efficient in preventing light transmission. Other colors, if highly concentrated, can also eliminate translucence but can weaken the tank since the pigment is technically a contaminate when introduced to polyethylene. Although natural colored polyethylene tanks transmit the most amount of light energy, tanks that are tinted (with the exception of black) will typically provide enough light energy to sustain photosynthesis and promote Algae growth. Therefore it cannot be stated that colored tanks do not promote Algae unless the amount of light energy transmission is properly evaluated. Any amount of light energy will allow Algae formation.

Can I store chemicals or fertilizers in Ace H₂O Water Only storage tanks?

No, Ace H₂O Water Only storage tanks are designed for water storage only. They are not rated to contain chemicals or fertilizers.

Are your tanks FDA compliant?

Ace Roto-Mold tanks are manufactured utilizing FDA compliant resins. Natural, black, blue and green colored tanks are in full compliance with current FDA standards for polyethylene tanks. However, certain colors (i.e. yellow) when blended in resin, may effect compliance. Consult the factory regarding other colors and FDA compliance. Please specify on your tank order if FDA compliance is required and we will assist in your selection.

What is the maximum temperature that your tanks can withstand?

Depending upon the chemicals to be stored, Ace Roto-Mold tanks will handle sustained temperatures of up to 120° F (49° C) and intermittent temperatures of up to 140° F (60° C). Consult the chemical manufacturer or chemical resistance chart on page 15 for recommendations regarding storage in polyethylene tanks and service temperature limits. Please note that higher service temperatures will lower the specific gravity rating of your tank.

Can I store petroleum products in your tanks?

Tanks manufactured by Ace Roto-Mold are suitable for storage of new, unused motor oil up to 500 gallons (1893 liters) in capacity. Industry testing has indicated that long-term storage (5 years or more) of oil can soften the tank walls and cause swelling. Therefore while limited capacity storage is permitted, the user must be aware of these long-term implications and limited tank life. All fitting gaskets must be Viton. Further, it is recommended that all oil installations feature secondary containment to manage any environmental implications. Used motor oil is not recommended for storage in Ace Roto-Mold tanks due to

contaminants. Also note that only cross-linked tanks are suitable for gasoline, diesel, kerosene and other petroleum based fuels.

Can I store Deionized water in your tanks?

Polyethylene tanks manufactured by Ace Roto-Mold are suitable for storage of Deionized water up to 100° F (38° C).

Do you manufacture tanks made from Nylon materials?

Nylon has become a popular material in the rotational molding industry. Nylon is best known for its strength, creep resistance, fatigue resistance and high service temperature. It has excellent chemical resistance to a wide range of reagents including gasoline and diesel fuel. Ace Roto-Mold can produce tanks in a Nylon material in sizes of 20 gallons or less.

Does the presence of ozone effect a polyethylene tank?

Ozone is sometimes used for the purification of water. According to the Ozone Solutions (<http://www.ozoneapplications.com/>), High Density Polyethylene (HDPE) is rated excellent for compatibility with ozone. Low Density Polyethylene (LDPE) is rated as Good compatibility (minor effect, slight corrosion or discoloration). Our DHI polypropylene fittings are only rated as Fair for ozone compatibility, so the fittings are not recommended for continuous use. Softening, loss of strength, and/or swelling may occur. Their data does not specify the ozone concentrations, although the materials were tested at ozone levels exceeding 1000 PPM. 100% ozone is not recommended in our tanks. Tanks should be inspected on a semi-annual basis.

Can your tanks be pressurized?

No, our tanks cannot be pressurized or exposed to vacuum.

Can your tanks be buried?

The only Ace Roto-Mold tanks designed for burial are the septic and cistern tanks. Other tanks are not designed to handle the pressure of surrounding earth and should not be buried.

What is the warranty on your tanks?

Den Hartog Industries' polyethylene tanks are warranted to be free from defects in materials and workmanship under normal use and service for a period of 24 months on polyethylene Stock Tanks, 60 months on Septic/Cistern Tanks and 36

months on all other polyethylene tanks. Warrantor's responsibility extends solely to repair and replacement of your Den Hartog product and its components parts. Warrantor does not assume responsibility for, nor shall be liable for, any special, incidental or consequential damages.

How many years will my tank last?

Life expectancy of a tank depends upon multiple variables. Some of these variables include; the type of material stored in the tank, if the tank is kept indoors or outdoors, if the tank is stationary or used in transportable applications, UV exposure. All of these factors, including several more, have an effect on a polyethylene tank.

Will freezing temperatures hurt my poly tank?

Freezing temperatures will not have an effect on a polyethylene tank, however if you plan to keep a liquid in the tank that you know will freeze, be sure to leave sufficient room for expansion. Be aware there is a greater chance of a polyethylene tank cracking during transportation in cold temperatures.

Fittings that are exposed to chemicals will have a low temperature rating equivalent to the freezing limit of the chemicals the fitting is exposed to. Note that heaters, heat bands or chemical inhibitors that prevent chemical freeze up will allow the fittings to be exposed to ambient temperatures below the freeze point of the chemical. Again, the low temperature rating of all fittings must be above the point at which the chemicals freeze or solidify.

Is there some way to tell when my tank was made?

All Ace Roto-Mold tanks are embossed with a date stamp in the month/year format. Please reference page 21 to view common stamp placements on different styles of Ace Roto-Mold tanks.

Are your tanks FDA approved and are they safe for water storage?

It is safe to store water in Ace Roto-Mold above ground tanks and below ground cisterns. Our natural colored polyethylene tanks and polypropylene lids and fittings are produced from FDA compliant materials. Please consult the factory regarding additional FDA compliant colors that are available.

What is the recommended tightness of the hoops on my tank?

The hoops should be tightened for full contact with the tank, however not to the point of tank distortion. The holes used to mount the hoop should be positioned close to the tank to allow full contact at the bottom of the leg and hoop contact

point. Please note that hoops with both j-bolts and feet are not intended to be tightened to the point of complete contact with the mounting surface.

Are these tanks repairable through plastic welding?

Yes, polyethylene tanks can be repaired through welding by qualified personnel.

How tight can I tighten a bulkhead fitting?

Be careful not to over tighten poly fittings. If over tightened, these fittings can be damaged and leak. Tighten nut to hand-tight plus ½ turn. If thread sealant is used, be certain that it is rated for use with the fittings and chemical to be contained.

What type of surface is required for placement of a vertical tank?

When selecting the tank site, insure that the site is level and that adequate drainage is provided for water runoff. The bottom of all tanks must be completely supported. Reinforced concrete support pads are recommended for tanks with capacities over 1000 gallons (3785 liters). In all cases be certain that the base material is designed to support the bearing capacity requirements of the tank, including seismic and wind loads. If the tank is installed in a stand or skid, note that the bearing capacity requirements of the concrete or soil will be increased. Always anchor the tank according to seismic or wind load zone requirements for the site. Always consult the applicable building codes governing the tank site for specific support and anchoring requirements. See Polyethylene Storage Tank Anchor Design on page 18.

Do you offer any type of Tank Anchoring Kits?

Den Hartog Industries currently offers a Tank Anchor Block Weldment for our Vertical Tanks. This Anchor Block Weldment facilitates anchoring the tank in position. Each tank requires 4 Anchor Block Weldments. A concrete pad that is properly reinforced and thick enough for the expansion anchor is required. **(Expansion anchors, eyebolts, cable clamps, wire ropes and cables thimbles provided by customer)**

Can I paint my tank?

Although there are products being marketed that claim to have successful adhesion to polyethylene, DHI does not support this practice. Paints with adhesion promoters will work for only a limited time before peeling is experienced. Polyethylene has a high thermal coefficient of expansion and contraction that causes the adhesion failure.

Can a septic tank be used for potable water?

No, drinking water can only be stored in our below ground cisterns and above ground tanks. The pigments used in septic tanks are not approved by the NSF for potable water.

Can I use a ribbed septic tank or cistern above ground?

Ace Roto-Mold's standard septic and cistern tanks are designed for below ground use only. Use of these tanks above ground could result in the deformation of the tank. However, Ace Roto-Mold Aquifer Low Profile Cistern Tanks are designed for and can be utilized in both below and above ground applications.

What certifications do you have on your septic tanks?

Ace Roto-Mold septic tanks are both IAPMO Z1000 and CAN/CSA-B-66 approved. IAPMO Z1000 standards are ANSI-accredited consensus standards for waste disposal products. They cover material, testing and marking requirements of these products. A CAN/CSA-B-66 standards specify minimum design and material requirements as well as manufacturing practices and markings for prefabricated septic tanks. Essentially all of the Canadian provinces require CSA approval prior to approving or evaluating a septic tank.

CHEMICAL RESISTANCE DATA CHART

Chemical Resistance Key:

R - Resistant N - Not Resistant V - Variable Resistance U - Unknown

Caution Key:

(P) - Plasticizer (A) - Known Stress Crack Agent (O) - Oxidizer (B) - Suspected Stress Crack Agent

Chemical	70°F	140°F
	(21°C)	(60°C)
Acetaldehyde -100% (A)	V	N
Acetic Acid -10% (A)	R	R
Acetic Acid - 60% (A)	R	V
Acetic Anhydride (B)	N	N
Aluminum Chloride - all conc.	R	R
Aluminum Fluoride - all conc.	R	R
Aluminum Sulfate - all conc.	R	R
Alums - all types	R	R
Ammonia - 100% dry gas	R	R
Ammonium Carbonate	R	R
Ammonium Chloride - sat'd.	R	R
Ammonium Fluoride - sat'd.	R	R
Ammonium Hydroxide - 10%	R	R
Ammonium Hydroxide - 28%	R	R
Ammonium Nitrate - sat'd.	R	R
Ammonium Persulfate - sat'd.	R	R
Ammonium Sulfate - sat'd.	R	R
Ammonium Metaphosphate - sat'd.	R	R
Amyl Acetate -100% (BP)	N	N
Amyl Alcohol - 100% (AP)	R	R
Amyl Chloride -100% (P)	N	N
Aniline - 100% (AP)	N	N
Aqua Regia (O)	N	N
Arsenic Acid - all conc.	R	R
Aromatic Hydrocarbons (BP)	N	N
Ascorbic acid -10%	R	R
Barium Carbonate - sat'd.	R	R
Barium Chloride - sat'd.	R	R
Barium Hydroxide	R	R
Barium Sulfate - sat'd.	R	R
Barium Sulfide - sat'd.	R	R
Beer	R	R
Benzene (BP)	N	N
Benzoic acid - all conc.	R	R
Bismuth Carbonate - sat'd.	R	R
Bleach Lye - 10%	R	R
Borax - sat'd.	R	R
Boric acid - all conc.	R	R
Boron Trifluoride	R	R
Brine	R	R
Bromine - liquid (O)	N	N
Butanediol 10% (A)	R	R
Butanediol - 60% (A)	R	R
Butanediol -100% (A)	R	R
Butter (B)	R	R
Butyl Acetate -100% (BP)	V	N
Butyl Alcohol -100% (A)	R	R
Butyric Acid - conc. (P)	N	N
Cadmium Salts	R	R
Calcium Bisulfide	R	R

Chemical	70°F	140°F
	(21°C)	(60°C)
Calcium Carbonate - sat'd	R	R
Calcium Chlorate - sat'd.	R	R
Calcium Chloride - sat'd	R	R
Calcium Hydroxide - conc.	R	R
Calcium Hypochlorite - bleach soln.	R	R
Calcium Nitrate - 50%	R	R
Calcium Oxide - sat'd.	R	R
Calcium Salts	R	R
Calcium Sulfate	R	R
Camphor Oil (BP)	N	N
Carbon Dioxide - all conc.	R	R
Carbon Disulphide	N	N
Carbon Monoxide	R	R
Carbon Tetrachloride (P)	N	N
Carbonic Acid	R	R
Castor Oil - conc. (A)	R	R
Chlorine -100% dry gas (O)	V	N
Chlorine Liquid (O)	N	N
Chlorine Water- 2% sat'd sol'n	V	R
Chlorobenzene (BP)	R	N
Chlorofoam (BP)	N	N
Chlorosulfonic Acid -100%	V	N
Chromic Acid - 10%	R	R
Chromic Acid - 50%	R	V
Cider (A)	R	R
Citric Acid - sat'd. (A)	R	R
Coconut Oil Alcohols (A)	R	R
Coffee	R	R
Cola Concentrates (A)	R	R
Copper Chloride - sat'd.	R	R
Copper Cyanide - sat'd.	R	R
Copper Fluoride - 2%	R	R
Copper Nitrate - sat'd.	R	R
Copper Sulfate - sat'd.	R	R
Corn Oil (A)	R	R
Cottonseed Oil (A)	R	R
Cresol - 100%	R	R
Cuprous Chloride - sat'd.	R	R
Detergents, synthetic (A)	R	R
Developers, photographic	R	R
Dextrin - sat'd.	R	R
Dextrose - sat'd.	R	R
Diazo Salts	R	R
Dibutylphthalate (B)	V	V
Dichlorobenzene (BP)	R	R
Diethyl Ketone (BP)	V	N
Diethylene Glycol (A)	R	R
Diglycolic Acid (A)	R	R
Dimethylamine	N	N
Disodium Phosphate	R	R

The information contained within this chart is based upon data supplied by resin manufacturers and is intended to be a general guide. Note that this data does not encompass all applications or service temperatures. For this reason, Den Hartog Industries, Inc. makes no claim as to the accuracy of this data and recommends that in all cases the final determination of suitability between the chemical(s) to be contained and the polyethylene tank material be verified with the chemical manufacturer(s).

CHEMICAL RESISTANCE DATA CHART

Chemical Resistance Key:

R - Resistant N - Not Resistant V - Variable Resistance U - Unknown

Caution Key:

(P) - Plasticizer (A) - Known Stress Crack Agent (O) - Oxidizer (B) - Suspected Stress Crack Agent

Chemical	70°F	140°F
	(21°C)	(60°C)
Emulsions, photographic (A)	R	R
Epsom Salts - Magnesium Sulfate	R	R
Ethyl Acetate -100% (BP)	V	N
Ethyl Alcohol -100% (A)	R	R
Ethyl Alcohol - 35% (A)	R	R
Ethyl Benzene (BP)	N	N
Ethyl Chloride (P)	N	N
Ethyl Ether (P)	N	N
Ethylene Chloride (BP)	N	N
Ethylene Glycol (A)	R	R
Fatty Acids (A)	R	R
Ferric Chloride - sat'd.	R	R
Ferric Nitrate - sat'd.	R	R
Ferrous Chloride - sat'd	R	R
Ferrous Sulfate	R	R
Fish Solubles (A)	R	R
Fluoboric Acid	R	R
Fluosilicic kid - conc.	R	V
Fluosilicic kid - 32%	R	R
Formic Acid - all conc.	R	R
Fructose - sat'd.	R	R
Fruit Pulp (B)	R	R
Furfural -100% (P)	N	N
Furfuryl Alcohol (BP)	N	N
Gallic Acid - sat'd. (A)	R	R
Gasoline (PB)	N	N
Glucose	R	R
Glycerine (A)	R	R
Glycol (A)	R	R
Glycolic Acid - 30% (A)	R	R
Grape Sugar- sat. ag	R	R
Heptane (PB)	N	N
Hexachlorobenzens	R	R
Hexanol, Tertiary (A)	R	R
Hydrobromic Acid - 50%	R	R
Hydrochloric Acid - all conc.	R	R
Hydrocyanic Acid - sat'd.	R	R
Hydrofluoric Acid - 40% (A)	R	R
Hydrofluoric Acid - 60% (A)	R	R
Hydrogen -100%	R	R
Hydrogen Chloride - dry gas	R	R
Hydrogen Peroxide - 30%	R	R
Hydrogen Sulfide	R	R
Hypochlorous Acid - conc	R	R
Inks (A)	R	R
Iodine - in KI Sol'n (O)	V	N
Lead Acetate - sat'd.	R	R
Lead Nitrate	R	R

Chemical	70°F	140°F
	(21°C)	(60°C)
Lime	R	R
Magnesium Carbonate - sat'd	R	R
Magnesium Chloride - sat'd.	R	R
Magnesium Hydroxide - sat'd.	R	R
Magnesium Nitrate - sat'd.	R	R
Magnesium Sulfate - sat'd.	R	R
Mercuric Chloride - 40%	R	R
Mercuric Cyanide - sat'd	R	R
Methyl Alcohol -100% (A)	R	R
Methylene Chloride -100% (PB)	N	N
Milk	R	R
Mineral Oils (P)	V	N
Molasses	R	R
Naphtha (PA)	V	N
Naphthalene (PB)	N	N
Nickel Chloride - conc.	R	R
Nickel Nitrate - sat'd.	R	R
Nickel Sulfate - conc.	R	R
Nicotine - dilute (A)	R	R
Nitric Acid - 0-30%	R	R
Nitric Acid - 30-50% (O)	R	V
Nitric Acid - 70% (O)	R	V
Nitric Acid - 95-98% (O)	N	N
Nitrobenzene -100% (PB)	N	N
Nonyl phenol ethoxylate (B)	N	N
Octane	R	R
Oxalic Acid - sat'd. (A)	R	R
Perchloroethylene (P)	N	N
Phosphorous Pentoxide	V	N
Photographic Solutions	R	R
Plating Solutions	R	R
Brass (A)	R	R
Cadmium (A)	R	R
Gold (A)	R	R
Nickel (A)	R	R
Silver (A)	R	R
Tin (A)	R	R
Zinc (A)	R	R
Potassium Acetate	R	R
Potassium Bicarbonate - sat'd.	R	R
Potassium Bromate -10%	R	R
Potassium Bromide - sat'd	R	R
Potassium Carbonate	R	R
Potassium Chlorate - sat'd.	R	R
Potassium Chloride - sat'd.	R	R
Potassium Chromate - 40%	R	R
Potassium Cyanide - sat'd	R	R
Potassium Dichromate - 40%	R	R
Potassium Ferri/Ferro Cyanide sat'd.	R	R

The information contained within this chart is based upon data supplied by resin manufacturers and is intended to be a general guide. Note that this data does not encompass all applications or service temperatures. For this reason, Den Hartog Industries, Inc. makes no claim as to the accuracy of this data and recommends that in all cases the final determination of suitability between the chemical(s) to be contained and the polyethylene tank material be verified with the chemical manufacturer(s).

CHEMICAL RESISTANCE DATA CHART

Chemical Resistance Key:

R - Resistant N - Not Resistant V - Variable Resistance U - Unknown

Caution Key:

(P) - Plasticizer (A) - Known Stress Crack Agent (O) - Oxidizer (B) - Suspected Stress Crack Agent

Chemical	70°F	140°F	Chemical	70°F	140°F
	(21°C)	(60°C)		(21°C)	(60°C)
Potassium Fluoride	R	R	Stannic Chloride - sat'd.	R	R
Potassium Hydroxide - 20%	R	R	Stannous Chloride - sat'd.	R	R
Potassium Hydroxide - conc.	R	R	Starch Solution - sat'd. (A)	R	R
Potassium Nitrate - sat'd.	R	R	Stearic Acid -100% (A)	R	R
Potassium Perchlorate -10%	R	R	Sulfuric Acid - 0-50%	R	R
Potassium Permanganate - 20%	R	R	Sulfuric Acid - 70% (O)	R	V
Potassium Persulfate - sat'd.	R	R	Sulfuric Acid - 80% (O)	R	N
Potassium Sulfate - conc	R	R	Sulfuric Acid - 96% (O)	V	N
Potassium Sulfide - conc.	R	R	Sulfuric Acid - 98% conc. (O)	V	N
Potassium Sulfite - conc.	R	R			
Propargyl Alcohol (A)	R	R	Sulfuric Acid - fuming (O)	N	N
Propyl Alcohol (A)	R	R	Sulfurous Acid	R	R
Propylene Dichloride -100% (PB)	N	N			
Propylene Glycol (A)	R	R	Tallow (P)	R	V
Pyridine (B)	R	U	Tannic Acid - sat'd (A)	R	R
			Tartaric Acid - 10%	R	R
Rayon Coagulating Bath (B)	R	R	Tetrahydrofuran	N	N
Resorcinol - sat'd.	R	R	Titanium Tetrachloride - sat'd. (B)	N	N
			Toluene (PB)	N	N
Salicylic Acid - sat'd.	R	R	Transformer Oil	R	V
Sea Water	R	R	Trichloroethylene (PB)	N	N
Selenic acid	R	R	Triethylene Glycol (B)	R	R
Shortening (A)	R	R	Trisodium Phosphate - sat'd	R	R
Silver Nitrate Solution	R	R	Turpentine (P)	N	N
Soap Solution - any conc. (A)	R	R			
Sodium Acetate - sat'd.	R	R	Urea - 0-30%	R	R
Sodium Benzoate - 35%	R	R	Urine	R	R
Sodium Bicarbonate - sat'd	R	R			
Sodium Bisulfate - sat'd	R	R	Vanilla Extract (A)	R	R
Sodium Bisulfite - sat'd	R	R	Varnish	R	N
Sodium Borate	R	R	Vinegar	R	R
Sodium Bromide - dilute	R	R			
Sodium Carbonate - conc	R	R	Water	R	R
Sodium Chlorate - sat'd.	R	R	Wetting Agents (A)	R	R
Sodium Chloride - sat'd	R	R	Whiskey (A)	R	R
Sodium Chlorite-30%	R	R	Wines (B)	R	R
Sodium Chlorite-50%	R	V			
Sodium Cyanide	R	R	Xylene (P)	N	N
Sodium Dichromate - sat'd.	R	R			
Sodium Ferri/Ferro Cyanide - sat'd	R	R	Yeast	R	R
Sodium Fluoride - sat'd.	R	R			
Sodium Hydroxide - conc.	R	R	Zinc Bromide - sat'd.	R	R
Sodium Hydroxide 35% or less	R	V	Zinc Carbonate - sat'd	R	R
Sodium Hydroxide 50% or above	V	N	Zinc Chloride - sat'd	R	R
Sodium Hypochlorite 0-12%	R	R	Zinc Oxide - sat'd	R	R
Sodium Hypochlorite 12-16.5%	R	V	Zinc Stearate	R	R
Sodium Hypochlorite 16.5 or higher	N	N	Zinc Sulfate - sat'd	R	R
Sodium Nitrate	R	R			
Sodium Sulfate	R	R			
Sodium Sulfide - sat'd.	R	R			
Sodium Sulfite - sat'd.	R	R			
Sodium thiosulphate pentahydrate	V	U			

The information contained within this chart is based upon data supplied by resin manufacturers and is intended to be a general guide. Note that this data does not encompass all applications or service temperatures. For this reason, Den Hartog Industries, Inc. makes no claim as to the accuracy of this data and recommends that in all cases the final determination of suitability between the chemical(s) to be contained and the polyethylene tank material be verified with the chemical manufacturer(s).

Polyethylene Storage Tank Anchor Design 5/25/10

Wind Velocity Pressure = q			q = 0.00256 x I x V ² x k			I = Importance Factor		0.95		V = Wind Velocity in MPH			110			k = Gust Correction Factor = (h/33) ^{2/7}				
q = basic velocity pressure = psf			Pressure Coefficient			0.6		Safety Factor			0.66			Seismic Coefficient					0.5	
Tank Model	Tank Diameter	Tank Weight	Total Height	Roof Height	Sidewall Height	Projected Roof Area	Projected Cyl. Area	Projected Total Area	Gust Correct. Factor	Wind Pressure	Total Wind Load	Max. Uplift At Anchor	Number Of Anchors	Number Of Anchor Bolts	Load Per Anchor Bolt	Load Per Wire Rope	Calculated Min. Wire Rope Diameter	Required Min. Wire Rope Dia.		
	Inches	Lb.	Inches	Inches	Inches	Ft.^2	Ft.^2	Ft.^2	=k	=q	=p	=R_a	=N_a	=N_b	=(R_a)/3	=R_a	=M_d	=R_d		
VT12500-142	142	3402	208	19.02	188.98	14.07	186.35	200.42	0.83	24.48	2944.07	15311.10	4	3	5103.70	15311.10	0.536	1/2		
VT10500-142	142	2800	175	19.02	155.98	14.07	153.81	167.88	0.79	23.30	2347.29	8254.43	4	3	2751.48	8254.43	0.289	5/16		
VT10500-142	142	2500	175	19.02	155.98	14.07	153.81	167.88	0.79	23.30	2347.29	8470.46	4	3	2823.49	8470.46	0.296	5/16		
VT9500-120	120	2352	213	16.08	196.92	10.05	164.10	174.15	0.84	24.65	2575.60	16231.51	4	3	5410.50	16231.51	0.568	9/16		
VT9150-120	120	2200	206	16.08	189.92	10.05	158.27	168.32	0.83	24.41	2465.67	13153.46	4	3	4384.49	13153.46	0.460	7/16		
VT7800-120	120	1900	176	16.08	159.92	10.05	133.27	143.32	0.79	23.34	2007.13	8832.75	4	3	2944.25	8832.75	0.309	5/16		
VT7000-142	142	1750	123	19.02	103.98	14.07	102.53	116.60	0.72	21.07	1474.08	3273.21	4	3	1091.07	3273.21	0.115	3/16		
VT6500-120	120	1502	152	16.08	135.92	10.05	113.27	123.32	0.76	22.38	1656.19	6168.39	4	3	2056.13	6168.39	0.216	1/4		
VT6250-102	102	1550	191	13.67	177.33	7.26	125.61	132.87	0.81	23.89	1904.84	11110.24	4	3	3703.41	11110.24	0.389	5/16		
VT5150-102	102	1350	159	13.67	145.33	7.26	102.95	110.21	0.77	22.67	1499.25	6944.27	4	3	2314.76	6944.27	0.243	1/4		
VT5000-102	102	1302	156	13.67	142.33	7.26	100.82	108.08	0.77	22.55	1462.36	6635.52	4	3	2211.84	6635.52	0.232	1/4		
VT4200-96	96	950	148	12.86	135.14	6.43	90.09	96.52	0.75	22.21	1286.49	6029.87	4	3	2009.96	6029.87	0.211	1/4		
VT4000-96	96	900	142	12.86	129.14	6.43	86.09	92.52	0.75	21.95	1218.68	5441.54	4	3	1813.85	5441.54	0.190	3/16		
VT3400-102	102	585	107	13.67	93.33	7.26	66.11	73.37	0.69	20.25	891.36	2733.42	4	3	911.14	2733.42	0.096	3/16		
VT3100-102	102	550	103	13.67	89.33	7.26	63.28	70.54	0.68	20.03	847.66	2487.72	4	3	829.24	2487.72	0.087	3/16		
VT3000-90	90	550	118	12.06	105.94	5.65	66.21	71.87	0.71	20.82	897.82	3554.52	4	3	1184.84	3554.52	0.124	3/16		
VT2500-90	90	420	100	12.06	87.94	5.65	54.96	60.62	0.67	19.86	722.30	2372.25	4	3	790.75	2372.25	0.083	3/16		
VT2150-102	102	417	71	13.67	57.33	7.26	40.61	47.87	0.61	18.01	517.26	860.32	4	3	286.77	860.32	0.030	3/16		
VT2050-86	86	402	93	11.52	81.48	5.16	48.66	53.82	0.66	19.45	628.17	1933.86	4	3	644.62	1933.86	0.068	3/16		
VT2000-90	90	375	83	12.06	70.94	5.65	44.34	49.99	0.64	18.83	564.81	1423.30	4	3	474.43	1423.30	0.050	3/16		
VT2000-64	64	465	156	8.57	147.43	2.86	65.52	68.38	0.77	22.55	925.21	7264.05	4	3	2421.35	7264.05	0.254	1/4		
VT1650-85	85	276	74	11.39	62.61	5.04	36.96	42.00	0.62	18.22	459.22	1087.41	4	3	362.47	1087.41	0.038	3/16		
VT1525-64	64	350	122	8.57	113.43	2.86	50.41	53.27	0.71	21.02	671.87	3988.02	4	3	1329.34	3988.02	0.140	3/16		
VT1500-85	85	250	69	11.39	57.61	5.04	34.01	39.05	0.61	17.86	418.50	905.42	4	3	301.81	905.42	0.032	3/16		
VT1500-64	64	335	115	8.57	106.43	2.86	47.30	50.16	0.70	20.67	622.04	3433.18	4	3	1144.39	3433.18	0.120	3/16		
VT1350-85	85	228	64	11.39	52.61	5.04	31.06	36.10	0.59	17.48	378.64	737.93	4	3	245.98	737.93	0.026	3/16		
VT1200-64	64	275	94	8.57	85.43	2.86	37.97	40.83	0.66	19.51	477.95	2052.99	4	3	684.33	2052.99	0.072	3/16		
VT1050-85	85	190	52	11.39	40.61	5.04	23.97	29.01	0.56	16.48	286.81	394.40	4	3	131.47	394.40	0.014	3/16		
VT1000-64	64	250	81	8.57	72.43	2.86	32.19	35.05	0.64	18.70	393.22	1367.53	4	3	455.84	1367.53	0.048	3/16		

Notes:

- The wire rope utilized in accordance with these recommendations must be equal to or greater in rated breaking strength to 6 x 37 Fiber Core Wire Rope as rated by the standard U.S. Simplified Practice Recommendations 198-50 or better. The wire rope coating must be electro-deposition zinc. Galvanized rope must be rated for a minimum of 110% of the calculated tensile strength.
- This anchor design allows for a Seismic 4 condition and UBC wind load rating of 110 MPH.
- Secondary containment installations must be installed in accordance with these results, but are not included with these recommendations.
- Anchor bolts utilized in compliance with these recommendations must be certified for the tensile loads specified and installed in accordance with the manufacturers recommendations.
- The installation of tank anchors according to these recommendations is based upon installation by qualified personnel.
- The anchor installation presented in these recommendations must be inspected at a minimum of 90 day intervals, or upon the occurrence of each recorded Weather Service wind gust advisory equal to or greater than 50% of the wind load specified in this analysis.
- The effective pull-out strength of the anchors specified in these recommendations are subject to the installation foundation. Therefore, this analysis does not remove the importance of the foundation design from these recommendations. The concrete mix, thickness, re-bar selection and site preparation and suitability are the responsibility of the installer.
- These recommendations do not modify nor extend the warranty provided by Den Hartog Industries for any tank installed in accordance with this recommendation.

Copyright. All information furnished within this document, electronic file or design correspondence is the property of Den Hartog industries, Inc. and shall not be used, disclosed to others or copied without the expressed written consent of Den Hartog Industries, Inc.

INSTALL TWO EYEBOLTS AT EACH ANCHOR LOCATION (BY CUSTOMER)

EYEBOLTS ARE TO BE ZINC PLATED AND RATED FOR THE WIRE ROPE SPECIFIED

10176 ANCHOR BLOCK WELDMENT 4 REQUIRED

CABLE CLAMPS 2 PER CONNECTION (BY CUSTOMER)

WIRE ROPE - SEE SCHEDULE FOR SIZE REQUIREMENT (CABLES BY CUSTOMER)

BE SURE TO USE CABLE THIMBLES AT ALL CONNECTION POINTS

IMPORTANT: PERIODICALLY CHECK CABLE TENSION AND ANCHOR BOLTS TO INSURE THEY HAVE NOT LOOSENED

INSULATE CABLE LOOP THRU TANK WITH HOSE SLEEVE (BY CUSTOMER)

USE EYEBOLTS TO SNUG UP CABLES. DO NOT OVER TENSION

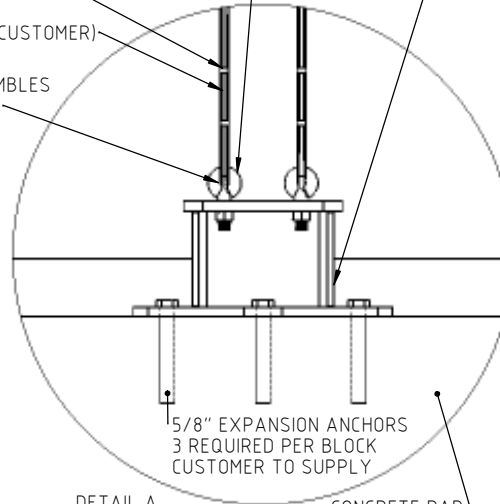

DETAIL A SCALE 1 : 10

CONCRETE PAD: BE SURE THAT PAD IS PROPERLY REINFORCED AND THICK ENOUGH FOR EXPANSION ANCHOR INSTALLATION

10176 ANCHOR BLOCK WELDMENT

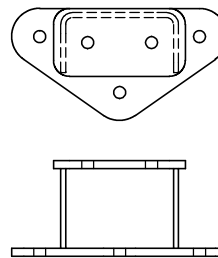

1.00" SPACE BETWEEN BLOCKS AND TANK

Tank Model	Number Of Anchor Blocks Required	Number Of Anchor Bolts Required Per Block	V=110 MPH	V=150 MPH
			Required Min. Wire Rope Dia. (.250" min.)	Required Min. Wire Rope Dia. (.250" min.)
	=Na	=Nb	=Rd	=Rd
VT12500-142	4	3	0.250	0.375
VT10500-142	4	3	0.250	0.250
VT10500-142	4	3	0.250	0.250
VT9500-120	4	3	0.250	0.375
VT9150-120	4	3	0.250	0.375
VT8000-120	4	3	0.250	0.250
VT7800-120	4	3	0.250	0.250
VT7000-142	4	3	0.250	0.250
VT6500-120	4	3	0.250	0.250
VT6250-102	4	3	0.250	0.250
VT5150-102	4	3	0.250	0.250
VT5000-102	4	3	0.250	0.250
VT4200-96	4	3	0.250	0.250
VT4000-96	4	3	0.250	0.250
VT3400-102	4	3	0.250	0.250
VT3100-102	4	3	0.250	0.250
VT3000-90	4	3	0.250	0.250
VT2500-90	4	3	0.250	0.250
VT2150-102	4	3	0.250	0.250
VT2050-86	4	3	0.250	0.250
VT2000-90	4	3	0.250	0.250
VT2000-64	4	3	0.250	0.250
VT1650-85	4	3	0.250	0.250
VT1525-64	4	3	0.250	0.250
VT1500-85	4	3	0.250	0.250
VT1500-64	4	3	0.250	0.250
VT1350-85	4	3	0.250	0.250
VT1200-64	4	3	0.250	0.250
VT1050-85	4	3	0.250	0.250
VT1000-64	4	3	0.250	0.250

DRAWN / DATE REH/5/1/12		MATERIAL	
APPRD. / DATE DHJ/5/1/12		NOTES:	
REV	DESCRIPTION	BY / DATE	CCN
ALL DIMENSIONS ARE IN DECIMAL INCHES TOLERANCES UNLESS OTHERWISE SPECIFIED		THIRD ANGLE PROJECTION ANSI 14.5M	
POLYETHYLENE		METAL DECIMAL ± .125" FRACTION ± 1/4" ANGLE ± 1°	
±1% @ 68°F		SHOT WEIGHT: SHIPPING WEIGHT: FINISH:	



Den Hartog
INDUSTRIES, INC.

Acu Roto-Mold Injection Molding Blow Molding Sowjoy

4010 HOSPERS DRIVE S. BOX 425, HOSPERS, IOWA 51238-0425

DESCRIPTION ANCHOR INSTALLATION DETAILS VT5150 AND LARGER

SCALE N.S. PART NO. 10175

Date Stamp Locations

VERTICAL TANKS

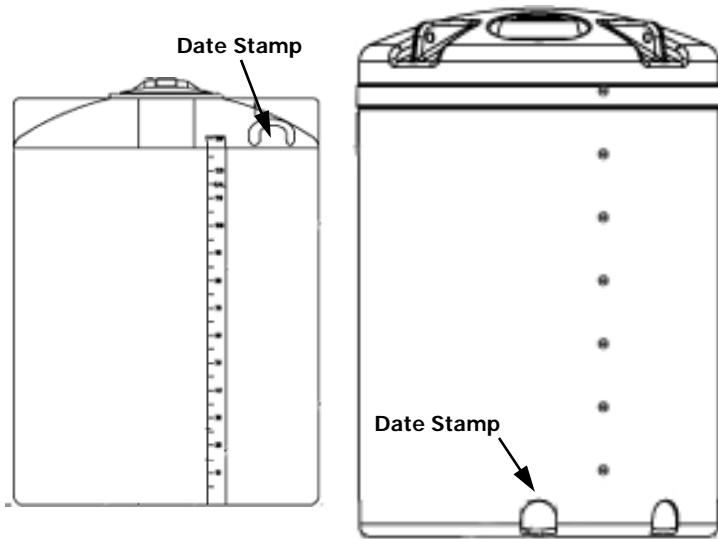

LEG TANKS

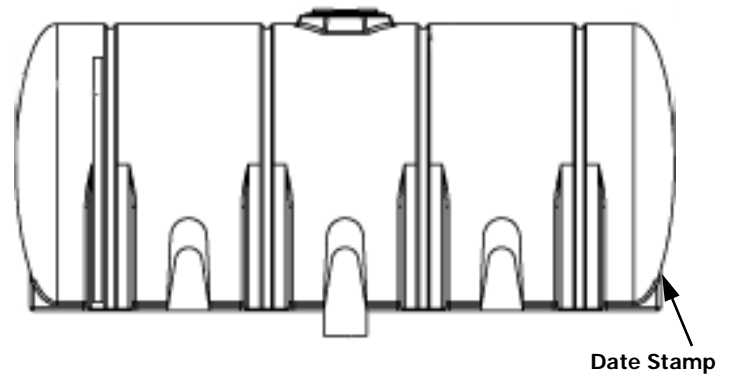

ELLIPTICAL TANKS

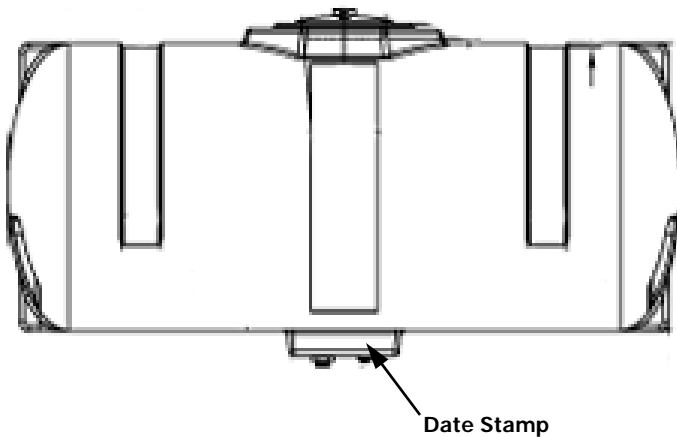

CONE BOTTOM TANKS

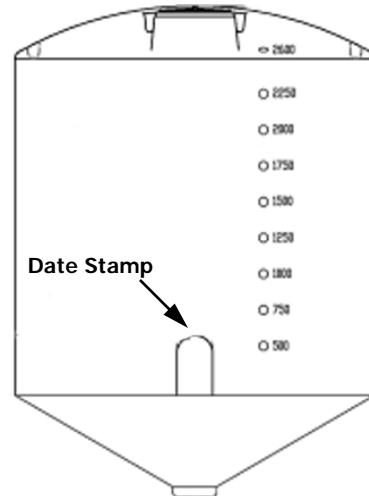

INDUCTOR TANKS

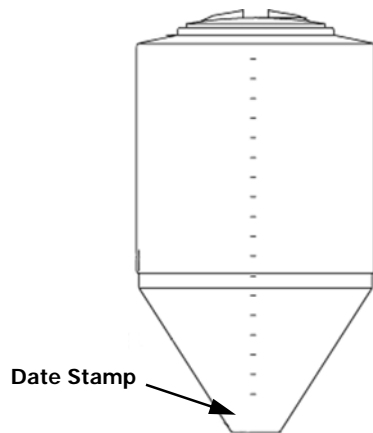

SPOT SPRAYER APPLICATOR TANKS

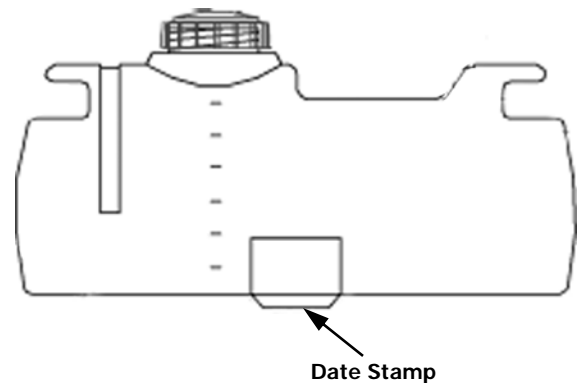

OPEN TOP CONTAINMENT TANKS

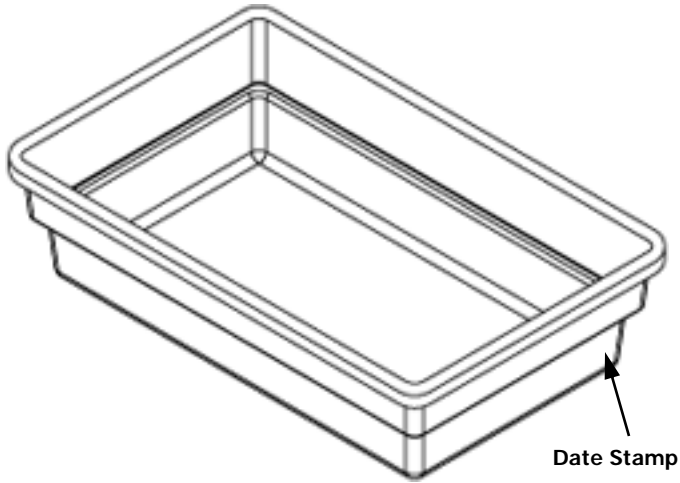

PICKUP TANKS

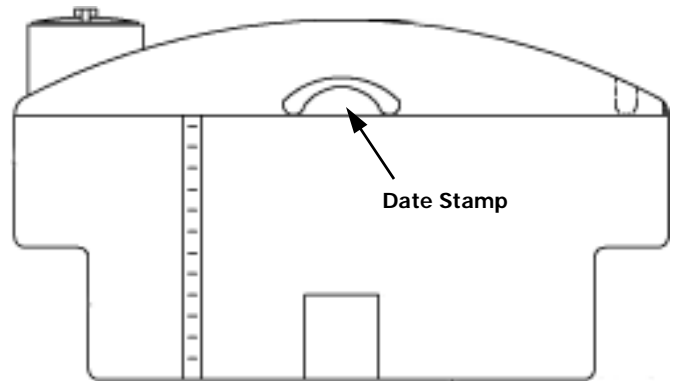

STOCK TANKS

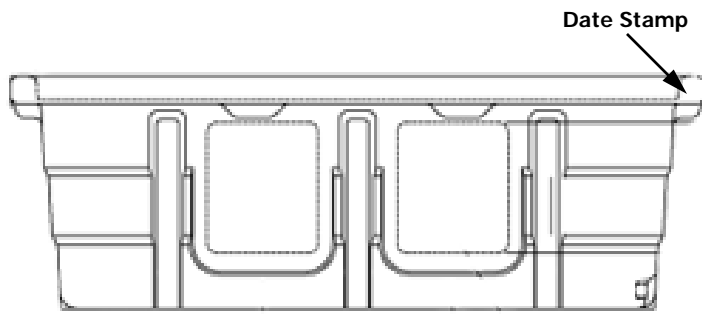

HORIZONTAL TANKS

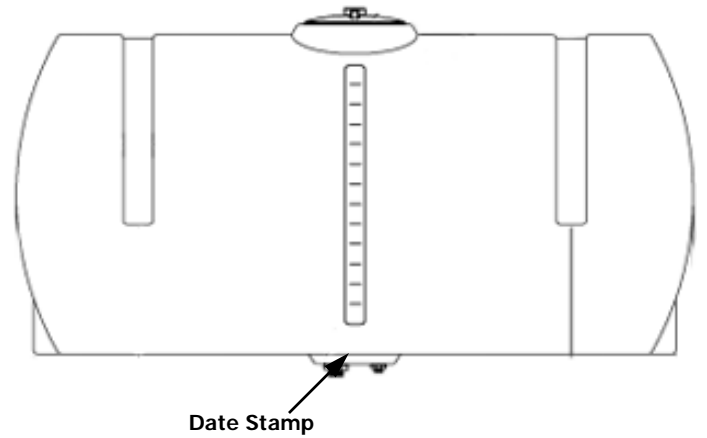

STACKABLE TOTES

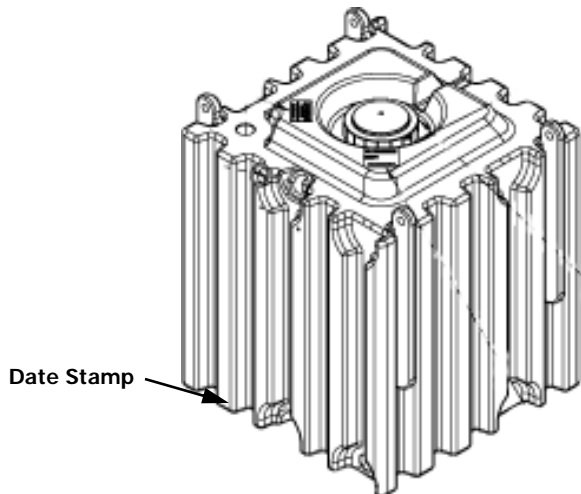

BULK STORAGE TANKS

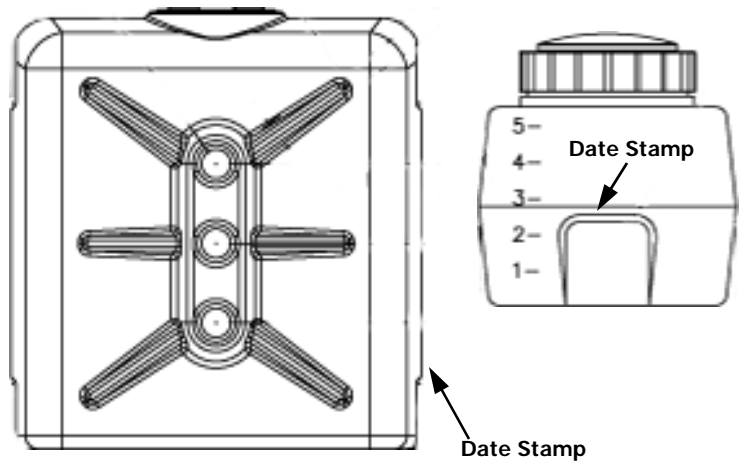

PCO TANKS

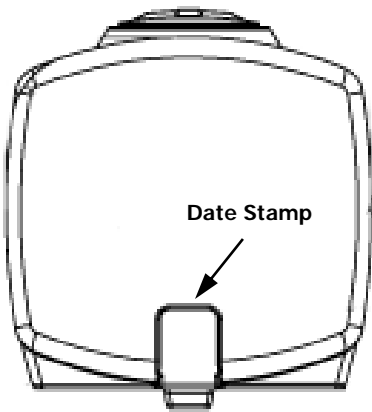
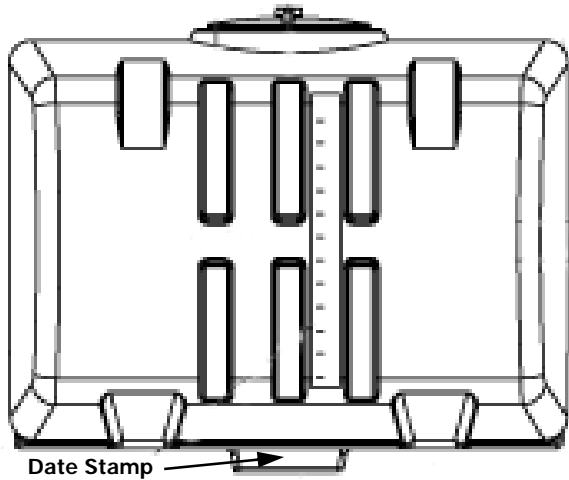

CROP CARE TANKS

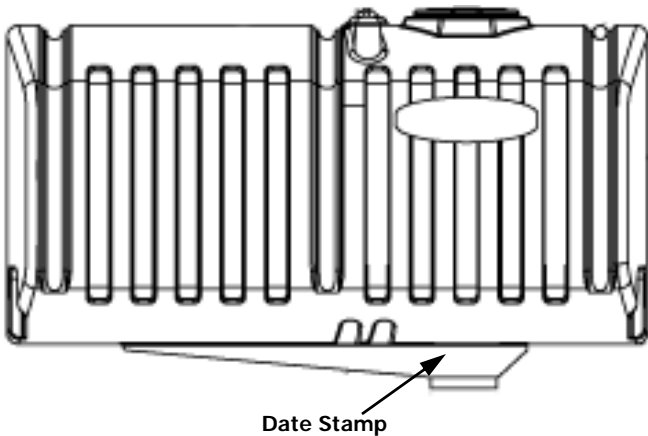

SEPTIC/CISTERN TANKS

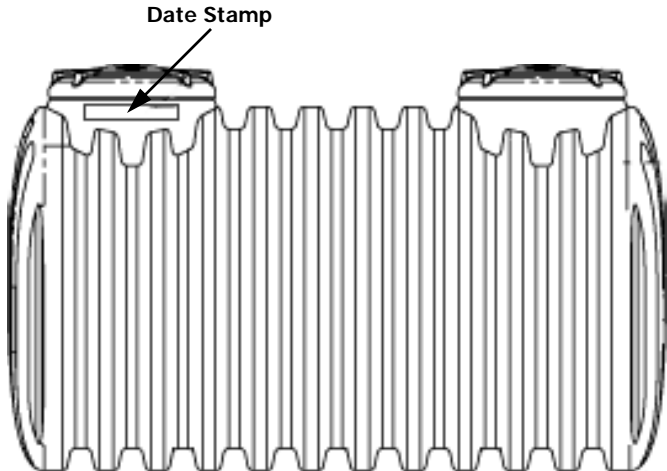

AQUIFER-LOW PROFILE CISTERNS

FLOAT DRUMS

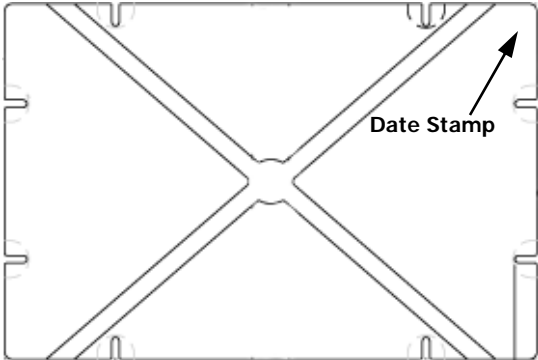
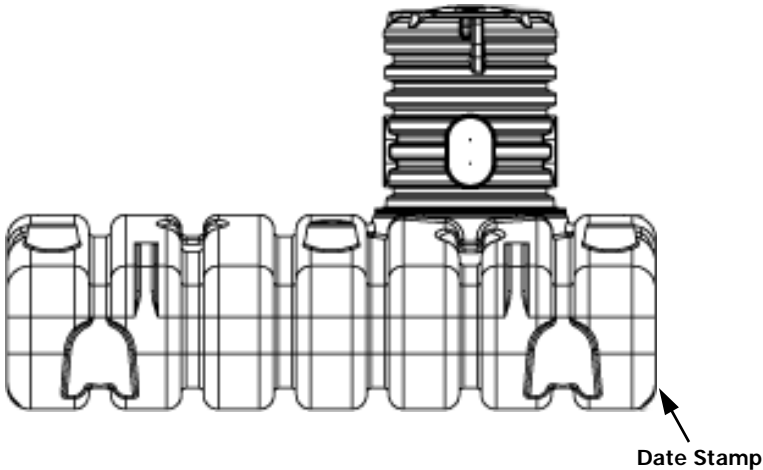

DUALLINE TANKS

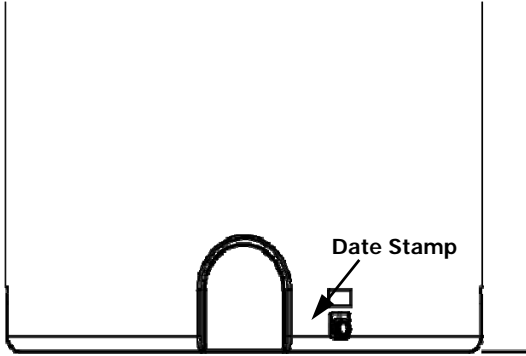
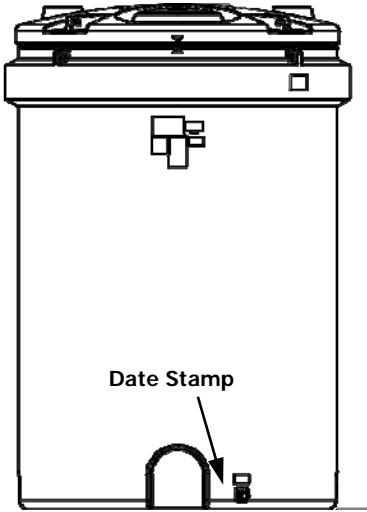

LIL' LUGGER UTILITY CART

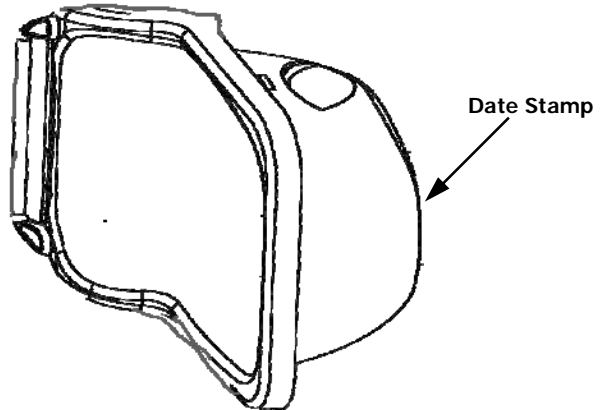
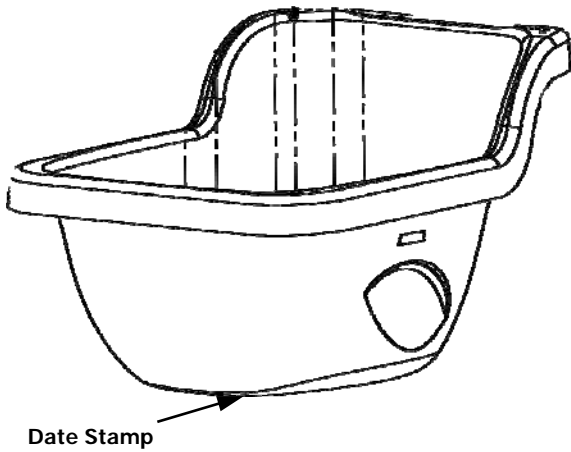

SPECIALTY RINSE TANKS

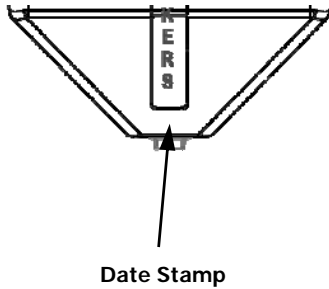
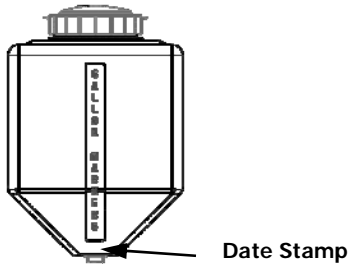



Den Hartog
INDUSTRIES, INC.

Den Hartog Industries, Inc. - Truckload Quantities

Updated 4-08-24

PART NO.	VERTICAL TANKS	WEIGHT	DIMENSIONS	
VT1350-86	1350 Gallon	228	86 x 65	13 tanks fill a rack
VT1500-64	1500 Gallon	335	64 x 115	9 tanks fill a stepdeck
VT1500-86	1500 Gallon	250	86 x 69	12 tanks fill a rack
VT1525-64	1525 Gallon	350	64 x 122	9 tanks fill a rack, with room to spare for some smaller tanks or 5 tanks fill a van or flatbed
VT1650-86	1650 Gallon	276	86 x 74	11 tanks fill a rack
VT2000-64	2000 Gallon	467	64 x 156	7 tanks fill a rack, with room to spare for some smaller tanks or 4 tanks fill a van or flatbed
VT2000-90	2000 Gallon	375	91 x 84	7 tanks fill a flatbed, van or stepdeck
VT2050-86	2050 Gallon	402	86 x 93	7 tanks fill a flatbed, van or stepdeck
VT2150-102	2150 Gallon	417	102 x 71	8 tanks fill a flatbed or stepdeck, with room to spare for some smaller tanks
VT2500-90	2500 Gallon	420	91 x 103	7 tanks fill a flatbed, van or stepdeck
VT2500-96	2500 Gallon	445	96 x 92	7 tanks fill a van or stepdeck
VT3000-90	3000 Gallon	550	91 x 120	6 tanks fill a stepdeck, 5 tanks fill a van or flatbed
VT3000-96	3000 Gallon	582	96 x 109	6 tanks fill a stepdeck
VT3100-102	3100 Gallon	550	102 x 103	6 tanks fill a stepdeck or flatbed, with room to spare for some smaller tanks
VT3400-102	3400 Gallon	585	102 x 107	6 tanks fill a stepdeck, with room to spare for some smaller tanks
VT4000-96	4000 Gallon	900	96 x 140	5 tanks fill a lowboy, with room to spare for some smaller tanks
VT4200-96	4200 Gallon	950	96 x 148	4 tanks fill a lowboy, with room to spare for some smaller tanks
VT4995-142	4995 Gallon	952	142 x 90	6 tanks fill a lowboy, with room to spare for some smaller tanks
VT5000-102	5000 Gallon	1302	102 x 156	4 tanks fill a flatbed or stepdeck
VT5150-102	5150 Gallon	1350	102 x 161	4 tanks fill a flatbed or stepdeck
VT6250-102	6250 Gallon	1550	102 x 194	3 tanks fill a flatbed or stepdeck
VT6500-120	6500 Gallon	1502	120 x 152	3 tanks fill a lowboy or stepdeck, with room to spare for some smaller tanks
VT7000-142	7000 Gallon	1750	142 x 125	4 tanks fill a lowboy, with room to spare for some smaller tanks
VT7800-120	7800 Gallon	1900	120 x 176	3 tanks fill a lowboy, with room to spare for some smaller tanks
VT8000-120	8000 Gallon	1930	120 x 180	3 tanks fill a stepdeck, with room to spare for some smaller tanks
VT9000-142	9000 Gallon	2002	142 X 154	3 tanks fill a lowboy, with room to spare for some smaller tanks
VT9150-120	9150 Gallon	2200	120 x 203	2 tanks fill a stepdeck, with room to spare for some smaller tanks
VT9500-120	9500 Gallon	2352	120 x 213	2 tanks fill a stepdeck, with room to spare for some smaller tanks
VT10500-2500	10500 Gallon	2500	142 x 177	3 tanks fill a lowboy, with room to spare for some smaller tanks
VT10500-2800	10500 Gallon	2800	142 x 177	3 tanks fill a lowboy, with room to spare for some smaller tanks
VT12500-142	12500 Gallon	3402	142 x 208	2 tanks fill a lowboy, with room to spare for some smaller tanks
VT15500-142	15500 Gallon	4002	142 x 247	2 tanks fill a lowboy, with room for some smaller tanks

PART NO.	WATER ONLY TANKS	WEIGHT	DIMENSIONS	
WO2500-VT	2500 Gallon Vertical	392	96 x 92	7 tanks fill a stepdeck
WO3000-VT	3000 Gallon Vertical	487	96 x 109	6 tanks fill a stepdeck

PART NO.	GUSSETED TANKS		WEIGHT	DIMENSIONS	
GV1350-86	1350	Gallon	209	86 x 62	13 tanks fill a rack
GV1500-86	1500	Gallon	230	86 x 69	12 tanks fill a rack
GV1650-86	1650	Gallon	257	86 x 74	11 tanks fill a rack
GV4995-142	4995	Gallon	952	142 x 97	6 tanks fill a lowboy, with room to spare for some smaller tanks
GV7000-142	7000	Gallon	1752	142 x 127	4 tanks fill a lowboy, with room to spare for some smaller tanks
GV10500-2500	10500	Gallon	2502	142 x 179	3 tanks fill a lowboy, with room to spare for some smaller tanks
GV10500-2800	10500	Gallon	2802	142 x 179	3 tanks fill a lowboy, with room to spare for some smaller tanks
GV12500-142	12500	Gallon	3402	142 x 208	2 tanks fill a lowboy, with room to spare for some smaller tanks
GV15500-142	15500	Gallon	4002	142 x 253	2 tanks fill a lowboy, with room to spare for some smaller tanks

PART NO.	FREE STANDING LEG TANKS WITHOUT SU		WEIGHT	DIMENSIONS	
FS1005-48	1005	Gallon	342	48 x 130	23 tanks fill a rack
FS1035-78	1035	Gallon Elliptical	292	78 x 90 x 52	16 tanks fill a rack
FS1065-56W	1065	Gal Hoops Req.	342	56 x 105	10 tanks fill a van or rack
FS1300-DW	1300	Gallon Hoops Req.	427	62 x 114	10 tanks fill a rack
FS1610-78	1610	Gallon ELLIPTICAL*	530	78 x 139 x 56	4 tanks on step deck or van
FS1750-62W	1750	Gal Hoops Req	616	62 x 147	7 tanks fill a rack, 4 tanks fill a flatbed, stepdeck or van
FS1800-2W	1800	Gal Hoops Req.	580	62 x 149	9 tanks fill a rack, 4 assembled fill a flatbed or stepdeck
FS1850-78	1850	Gal Hoops Req. ELLIPTICAL	571	78 x 139 x 63	7 tanks fill a rack, 4 assembled fill a flatbed or stepdeck
FS2350-88	2350	Gal Hoops Req. ELLIPTICAL	920	88 x 146 x 63	7 tanks fill a rack
FS2600-2W	2600	Gal Hoops Req.	850	62 x 212	5 tanks fill a van, stepdeck or flatbed, 3 assembled fill a flatbed or stepdeck
FS2750-88	2750	Gal Hoops Req. ELLIPTICAL	1150	88 x 146 x 70	5 tanks fill a rack, with room to spare for some smaller tanks or 4 tanks fill a flatbed or stepdeck
FS3250-88	3250	Gal Hoops Req. ELLIPTICAL	1208	88 x 146 x 79	4 tanks fill a stepdeck or flatbed
FS3750-88	3750	Gal Hoops Req ELLIPTICAL	1422	88 x 146 x 91	4 tanks fill a stepdeck or flatbed
FS4200-92	4200	Gal Hoops Req. ELLIPTICAL	1648	92 x 195 x 80	3 tanks fill a stepdeck or flatbed
FS4250-88	4250	Gal Hoops Req. Elliptical	1617	88 x 146 x 101	4 tanks fill a stepdeck or flatbed

PART NO.	FREE STANDING LEG TANKS WITH SUMP		WEIGHT	DIMENSIONS	
FM1065-56S	1065	Gal Hoops Req.	342	56 x 105	10 tanks fill a van or rack
FM1300-DS	1300	Gallon Hoops Req.	427	62 x 114	10 tanks fill a rack
FM1610-62	1610	Gal Hoops Req. ELLIPTICAL	530	78 x 139 x 58	4 tanks on step deck or van
FM1750-62S	1750	Gal Hoops Req	616	62 x 147	7 tanks fill a rack, 4 tanks fill a flatbed, stepdeck or van
FM1800-2S	1800	Gal Hoops Req.	580	62 x 149	9 tanks fill a rack, 4 assembled fill a flatbed or stepdeck
FM1850-78	1850	Gal Hoops Req. ELLIPTICAL	571	78 x 139 x 63	7 tanks fill a rack, 4 assembled fill a flatbed or stepdeck
FM2350-88S	2350	Gal Hoops Req. ELLIPTICAL	920	88 x 146 x 63	4 tanks fill a flatbed or stepdeck
FM2600-2S	2600	Gal Hoops Req.	850	62 x 212	5 tanks fill a van, stepdeck or flatbed, 3 assembled fill a flatbed or stepdeck
FM2750-88S	2750	Gal Hoops Req. ELLIPTICAL	1150	88 x 146 x 70	4 tanks fill a flatbed or stepdeck
FM3200-2S	3200	Gal Hoops Req ELLIPTICAL	1100	88 x 172 x 74	5 tanks fill a rack, 3 assembled fill a rack with room to spare for some smaller tanks
FM3250-88S	3250	Gal Hoops Req. ELLIPTICAL	1208	88 x 146 x 79	4 tanks fill a stepdeck or flatbed
FM3750-88S	3750	Gal Hoops Req. Elliptical	1422	88 x 146 x 91	4 tanks fill a stepdeck or flatbed
FM4200-92	4200	Gal Hoops Req. ELLIPTICAL	1648	92 x 195 x 80	3 tanks fill a stepdeck or flatbed
FM4250-88S	4250	Gal Hoops Req. Elliptical	1617	88 x 146 x 101	4 tanks fill a stepdeck or flatbed

PART NO.	ELLIPTICAL TANKS		WEIGHT	DIMENSION	
HE1000-78	1000	Gallon	287	78 x 90 x 49	12 tanks fill a van, 16 tanks fill a rack
HED1000-78	1000	Gallon Deep (8.5") Sump	287	78 x 90 x 49	11 tanks fill a van, 15 tanks fill a rack
HE1250-78	1250	Gallon	402	78 x 92 x 60	10 tanks fill a van
HED1250-78	1250	Gallon Deep (8.5") Sump	402	78 x 92 x 60	10 tanks fill a van
HE1600-78	1600	Gallon	439	78 x 138 x 49	8 tanks fill a stepdeck
HED1600-78	16000	Gallon Deep (8.5") Sump	439	78 x 138 x 49	8 tanks fill a stepdeck

PART NO.	CONE BOTTOM TANKS		WEIGHT	DIMENSION	**load configuration includes equal amount stands
CB1000-64	1000	Gallon-45 deg	252	64 x 98	6 tanks fill a van
CB1000-90	1000	Gallon-15 deg	212	91 X 54	9 tanks fill a flatbed or stepdeck
CB1005-64	1005	Gallon-15 deg	222	64 x 86	10 tanks in a van
CB1150-90	1150	Gallon-15 deg	242	91 x 67	8 tanks on step deck; 7 in a van
CB1200-90	1200	Gallon-15 deg	242	91 X 62	10 tanks fill a van
CB1300-90	1300	Gallon-15 deg	262	91 X 65	7 tanks w/stand fill flatbed or stepdeck
CB1490-64	1490	Gallon-45 deg	340	64 x 132	4 tanks fill a flatbed or stepdeck or 6 tanks fill a rack with room to spare for some smaller tanks
CB1500-96	1500	Gallon-30 deg	252	96 x 80	6 tanks fill a flatbed or stepdeck
CB1550-90	1550	Gallon-30 deg	286	91 X 88	6 tanks w/stand fill flatbed or stepdeck
CB1600-90	1600	Gallon-30 deg	284	91 X 85	7 tanks w/stand fill flatbed or stepdeck
CB1700-86	1700	Gallon-15 deg	284	86 x 85	7 tanks w/stand fill flatbed or stepdeck
CB1750-90	1750	Gallon-15 deg	308	91 x 82	7 tanks in a van
CB2000-96	2000	Gallon-30 deg	292	96 x 96	6 tanks fill a flatbed or stepdeck
CB2450-90	2450	Gallon-15 deg	437	91 X 114	6 tanks w/stand fill low boy, 5 tanks w/stand fill flatbed or stepdeck
CB2495-90	2495	Gallon-30 deg	487	91 X 119	6 tanks w/stand fill low boy, 4 tanks w/stand fill flatbed or stepdeck w/10' remaining
CB2500-90	2500	Gallon-15 deg	435	91 X 111	6 tanks fill a stepdeck, 5 tanks fill a flatbed
CB2550-90	2550	Gallon-30 deg	502	91 X 126	6 tanks w/stand fill low boy, 4 tanks w/stand fill flatbed or stepdeck w/8' remaining
CB2600-90	2600	Gallon-30 deg	500	91 X 123	4 tanks fill a flatbed or stepdeck, will room to spare for some smaller tanks
CB2600-86	2600	Gallon-45 deg	500	86 x 146	4 tanks fill a flatbed or stepdeck
CB3000-90	3000	Gallon-15 deg	550	91 X 128	6 tanks fill a lowboy, 4 tanks fill a flatbed or stepdeck with room to spare for some smaller tanks
CB3000-96	3000	Gallon-30 deg	552	96 x 125	5 tanks fill a lowboy, 4 tanks fill a flatbed or stepdeck with room to spare for some smaller tanks
CB4200-122	4200	Gallon-15 deg	1102	122 x 113	4 tanks fill a stepdeck
CB4600-102	4600	Gallon-15 deg	1200	102 x 155	3 tanks fill a flatbed or stepdeck, with room to spare for some smaller tanks
CB4900-102	4900	Gallon-15 deg	1300	102 x 159	3 tanks fill a flatbed or stepdeck, with room to spare for some smaller tanks
CB6000-122	6000	Gallon-15 deg	1602	122 x 162	3 tanks fill a stepdeck
CB6900-122	6900	Gallon-15 deg	1700	122 x 168	3 tanks fill a stepdeck, with room to spare for some smaller tanks
CB7500-142	7500	Gallon-15 deg	1677	142 x 163	3 tanks fill a lowboy, with room to spare for some smaller tanks
CB8250-122	8250	Gallon-15 deg	2102	122 x 195	2 tanks fill a stepdeck, with room to spare for some smaller tanks
CB10500-142	10500	Gallon-15 deg	2502	142 x 209	2 tanks fill a lowboy, with room to spare for some smaller tanks
CB12500-142	12500	Gallon-15 deg	3402	142 x 239	2 tanks fill a lowboy, with room to spare for some smaller tanks

PART NO.	DOUBLE WALL VERTICAL TANKS		WEIGHT	DIMENSIONS	
DW1000-77	1000	Gallon	552	77 x 82	8 tanks fill a van
DW1500-77	1500	Gallon	673	77 x 119	8 tanks will fill a rack trailer, 8 tanks will fill a stepdeck, 5 tanks will fill a flatbed
DW2000-102	2000	Gallon	907	102 x 97	6 tanks will fill a stepdeck or flatbed
DW2500-102	2500	Gallon	1153	102 x 119	5 tanks will fill a stepdeck or flatbed
DW3000-102	3000	Gallon	1512	102 x 141	4 tanks fill a stepdeck or flatbed
DW3500-102	3500	Gallon	1707	102 x 164	3 tanks fill a stepdeck or flatbed
DW6000-120	6000	Gallon	3001	120 x 191	2 tanks fill a stepdeck with some room for smaller tanks
DW6500-120	6500	Gallon	3202	120 x 207	2 tanks fill a stepdeck with some room for smaller tanks

PART NO.	SEPTIC TANKS		WEIGHT	DIMENSIONS	
AST-0750-1	750	Gallon Single Compartment	259	60 x 70 60	18 tanks fill a rack, with room to spare for some smaller tanks
AST-1000-1	1000	Gallon Single Compartment	390	60 x 101 x 60	18 tanks fill a rack, with room to spare for some smaller tanks
AST-1000-2	1000	Gallon Two Compartments	436	60 x 101 x 60	18 tanks fill a rack, with room to spare for some smaller tanks
AST-1250-1	1250	Gallon Single Compartment	443	58 x 118 x 72	10 tanks fill a rack, with room to spare for smaller tanks or 7 tanks fill a stepdeck
AST-1250-2	1250	Gallon Two Compartments	489	58 x 118 x 72	10 tanks fill a rack, with room to spare for smaller tanks or 7 tanks fill a stepdeck
AST-1500-1	1500	Gallon Single Compartment	528	58 x 137 x 72	10 tanks fill a rack, with room to spare for smaller tanks or 7 tanks fill a stepdeck
AST-1500-2	1500	Gallon Two Compartments	574	58 x 137 x 72	10 tanks fill a rack, with room to spare for smaller tanks or 7 tanks fill a stepdeck

PART NO.	LOW PROFILE SEPTIC TANKS		WEIGHT	DIMENSIONS	
LPS-1000-1	1000	Gallon Low Profile	513	72 x 121 x 58	11 tanks fill a rack, with room to spare for some smaller tanks
LPS-1000-2	1000	Gallon Low Profile 2 Compartment	533	72 x 121 x 58	11 tanks fill a rack, with room to spare for some smaller tanks
LPS-1250-1	1500	Gallon Low Profile	588	72 x 137 x 58	10 tanks fill a rack, with room to spare for some smaller tanks
LPS-1250-2	1500	Gallon Low Profile 2 Compartment	608	72 x 137 x 58	10 tanks fill a rack, with room to spare for some smaller tanks
LPS-1500-1	2000	Gallon Low Profile	694	72 x 153 x 58	9 tanks fill a rack, with room to spare for some smaller tanks
LPS-1500-2	2000	Gallon Low Profile 2 Compartment	714	73 x 153 x 58	9 tanks fill a rack, with room to spare for some smaller tanks

PART NO.	CISTERN TANKS		WEIGHT	DIMENSIONS	
AST-0850-1W	850	Gallon	259	60 x 70 x 60	18 tanks fill a rack, with room to spare for some smaller items
AST-1150-1W	1150	Gallon	414	60 x 101 x 60	18 tanks fill a rack, with room to spare for some smaller items
AST-1450-1W	1450	Gallon	473	58 x 118 x 72	10 tanks fill a rack, with room to spare for some smaller items or 7 tanks fill a stepdeck
AST-1700-1W	1700	Gallon	567	58 x 137 x 72	10 tanks fill a rack, with room to spare for some smaller items or 7 tanks fill a stepdeck

PART NO.	AQUIFER LOW-PROFILE CISTERN TANKS		WEIGHT	DIMENSIONS	
ACT1000-LPB	1000	Gallon w/ Burial Lid	559	98 x 111 x 36	14 tanks fill a stepdeck
ACT1000-LPG	1000	Gallon w/ Ground Access Assembly	595	98 x 111 x 36	14 tanks fill a stepdeck
ACT1500-LPB	1500	Gallon w/ Burial Lid	702	98 x 111 x 48	10 tanks fill a stepdeck
ACT1500-LPG	1500	Gallon w/ Ground Access Assembly	738	98 x 111 x 48	10 tanks fill a stepdeck
ACT2000-LPB	2000	Gallon w/ Burial Lid	917	98 x 158 x 45	7 tanks fill a stepdeck
ACT2000-LPG	2000	Gallon w/ Ground Access Assembly	953	98 x 158 x 45	7 tanks fill a stepdeck
ACT2500-LPB	2500	Gallon w/ Burial Lid	1031	98 x 158 x 54	7 tanks fill a stepdeck
ACT2500-LPG	2500	Gallon w/ Ground Access Assembly	1067	98 x 158 x 54	7 tanks fill a stepdeck



PH: 800-342-3408 FAX: 712-752-8222

Updated 4/2024

PART NO.	VERTICAL TANKS - DOME TOP	CLASS	WGT	FSU	SINGLE QNTY	PLT QNTY		MAX PALLET DIMS	PROD DIMS	NOTES
VT0010-12	10 Gallon	150	9	FSU	BOX or SW	1 to 24			12 x 25	
VT0020-16	20 Gallon	250	15	FSU	BOX or SW	3 to 24			16 x 28	
VT0025-18	25 Gallon	250	14	FSU	BOX or SW	3 to 24			18 x 30	
VT0040-18	40 Gallon	250	19	FSU	SW	4 to 15			18 x 43	
VT0055-20	55 Gallon	250	23	FSU	CB	4 to 8			20 x 47	
VT0065-23	65 Gallon	250	27	FSU	CB	4 to 8			23 x 42	
VT0110-32	110 Gallon	300	42	S	CB	4 to 5			32 x 41	
VT0135-23	135 Gallon	300	47	S	CB				23 x 82	
VT0300-42	300 Gallon	300	74		CB				42 x 55	
VT0405-52	405 Gallon	300	92		CB				52 x 48	
VT0425-42	425 Gallon	300	102		CB				42 x 75	
VT0505-46	505 Gallon	300	120		CB				46 x 80	
VT0550-52	550 Gallon	300	118		CB				52 x 66	
VT0600-46	600 Gallon	300	132		CB				46 x 91	
VT0625-64	625 Gallon	400	102		CB				64 x 50	
VT0800-46	800 Gallon	300	177		CB				46 x 118	
VT0900-46	900 Gallon	300	222		CB				46 x 132	
VT1000-64	1000 Gallon	300	252		CB				64 x 81	
VT1050-86	1050 Gallon	400	192		CB				86 x 54	
VT1200-64	1200 Gallon	300	277		CB				64 x 97	
VT1350-86	1350 Gallon	400	230		CB				86 x 65	
VT1500-64	1500 Gallon	300	337		CB				64 x 115	
VT1500-86	1500 Gallon	400	252		CB				86 x 69	
VT1525-64	1525 Gallon	300	352		CB				64 x 122	
VT1650-86	1650 Gallon	400	280		CB				86 x 74	
VT2000-64	2000 Gallon	300	467		CB				64 x 156	
VT2000-90	2000 Gallon	400	377		CB				91 x 84	
VT2050-86	2050 Gallon	300	402		CB				86 x 93	
VT2150-102	2150 Gallon	-	417		CB				102 x 71	
VT2500-90	2500 Gallon	400	422		CB				91 x 103	
VT2500-96	2500 Gallon	-	445		CB				96 x 92	
VT3000-90	3000 Gallon	400	552		CB				91 x 120	
VT3000-96	3000 Gallon	-	582						96 x 109	
VT3100-102	3100 Gallon	-	552						102 x 103	
VT3400-102	3400 Gallon	-	587						102 x 107	
VT4000-96*	4000 Gallon	-	902						96 x 140	FLAT/STEP
VT4200-96*	4200 Gallon	-	952						96 x 148	FLAT/STEP
VT4995-142*	4995 Gallon	-	952						142 x 90	STEP
VT5000-102*	5000 Gallon	-	1302						102 x 156	FLAT/STEP
VT5150-102*	5150 Gallon	-	1352						102 x 161	FLAT/STEP
VT6250-102*	6250 Gallon	-	1552						102 x 194	FLAT/STEP
VT6500-120*	6500 Gallon	-	1502						120 x 152	FLAT/STEP
VT7000-142*	7000 Gallon	-	1752						142 x 125	FLAT/STEP
VT7800-120*	7800 Gallon	-	1902						120 x 176	FLAT/STEP
VT8000-120*	8000 Gallon	-	1932						120 x 180	FLAT/STEP

PART NO.	VERTICAL TANKS - DOME TOP continued	CLASS	WGT	FSU	SINGLE QNTY	PLT QNTY		MAX PALLET DIMS	PROD DIMS	NOTES
VT9000-142*	9000 Gallon	-	2002						142 x 154	DBL DROP FLAT/STEP FLAT/STEP DBL DROP DBL DROP DBL DROP DBL DROP
VT9150-120*	9150 Gallon	-	2202						120 x 203	
VT9500-120*	9500 Gallon	-	2352						120 x 213	
VT10500-2500*	10500 Gallon	-	2502						142 x 177	
VT10500-2800*	10500 Gallon	-	2802						142 x 177	
VT12500-142*	12500 Gallon	-	3402						142 x 208	
VT15500-142*	15500 Gallon	-	4002						142 x 247	
*INDICATES HEAVY DUTY FITTING										

PART NO.	WATER ONLY TANKS	CLASS	WGT	FSU	SINGLE QNTY			MAX PALLET DIMS	PROD DIMS	NOTES
WO2500-VT*	2500 Gallon Vertical	400	392		CB				96 x 92	
WO3000-VT*	3000 Gallon Vertical		487						96 x 109	
*only for materials 1.0 specific gravity or less										

PART NO.	VERTICAL TANKS - FLAT TOP	CLASS	WGT	FSU	SINGLE QNTY	PLT QNTY		MAX PALLET DIMS	PROD DIMS	NOTES
VT0075-23	75 Gallon	300	30	FSU	CB	4 to 8		50 x 46 x 97 280#	23 x 50	
VT0100-28	100 Gallon	300	38	FSU	CB	4 to 6		56 x 46 x 90 256#	28 x 45	
VT0105-23	105 Gallon	250	40	FSU	CB	4		48 x 46 x 72 192#	23 x 65	
VT0130-32	130 Gallon	300	47	S	CB				32 x 46	
VT0135-28	135 Gallon	300	47	S	CB				28 x 59	
VT0160-28	160 Gallon	300	58		CB				28 x 68	
VT0175-31	175 Gallon	300	56		CB				31 x 61	
VT0180-40	180 Gallon	300	50		CB				40 x 45	
VT0210-40	210 Gallon	300	58		CB				40 x 49	
VT0225-31	225 Gallon	300	67		CB				31 x 76	
VT0265-31	265 Gallon	300	76		CB				31 x 88	
VT0295-42	295 Gallon	300	74		CB				42 x 55	
VT0300-35	300 Gallon	300	88		CB				35 x 81	
VT0420-42	420 Gallon	300	102		CB				42 x 75	
VT0500-46	500 Gallon	300	120		CB				46 x 77	
VT0850-54	850 Gallon	300	184		CB				54 x 94	

PART NO.	VERTICAL STANDS	CLASS	WGT	FSU	SINGLE QNTY	PLT QNTY		MAX PALLET DIMS	PROD DIMS	NOTES
VT28/31-STP	31-1/2" Poly Stand	300	35	FSU	SW	2 to 5			39 x 24	
VT160-28ST	160 Gallon metal stand	150	83		P	1			30 x 26	
VT265-31ST	265 Gallon metal stand	150	89		P	1			33 x 26	
VT300-35ST	300 Gallon metal stand	150	114		P	1			37 x 38	

PART NO.	GUSSETED TANKS	CLASS	WGT	FSU	SINGLE QNTY			MAX PALLET DIMS	PROD DIMS	NOTES
GV1050-86	1050 Gallon	400	177		CB				86 x 50	
GV1350-86	1350 Gallon	400	209		CB				86 x 62	
GV1500-86	1500 Gallon	400	230		CB				86 x 69	
GV1650-86	1650 Gallon	400	257		CB				86 x 74	
GV4995-142	4995 Gallon	-	952						142" x 97"	DBL DROP FLAT/STEP DBL DROP DBL DROP DBL DROP DBL DROP DBL DROP
GV07000-142	7000 Gallon Gusseted	-	1752						142" x 127"	
GV10500-2500	10500 Gallon Gusseted	-	2502						142" x 179"	
GV10500-2800	10500 Gallon Gusseted	-	2802						142" x 179"	
GV12500-142	12500 Gallon Gusseted	-	3402						142" x 208"	
GV155000-142	15500 Gallon Gusseted	-	4002						142" x 253"	

PART NO.	FREE STANDING HORIZONTAL WITHOUT SUMP	CLASS	WGT	FSU	SINGLE QNTY	PLT QNTY		MAX PALLET DIMS	PROD DIMS	NOTES
FS0035-18	35 Gallon	250	16	FSU	BOX	4 to 12		56 x 40 x 81 208#	18 x 34	TANK/HOOP/SKID COMBINATIONS SHIP ASSEMBLED
FS0055-23	55 Gallon	300	22	FSU	SW	6		48 x 48x 80 182#	23 x 34 x 27	
FS0065-24	65 Gallon	250	33	FSU	SW	4 to 6		48 x 48 x 83 238#	24 x 39	
FS0070-24	70 Gallon Stackable	250	37	FSU	SW	3 to 6		50 x 40 x 95 250#	24 x 39	
FS0125-32	125 Gallon	250	54	S	P	1 to 2		40 x 42x 70 158#	32 x 44	
FS0165-32	165 Gallon	250	72		P	1 to 2		54 x 40 x 69 180#	32 x 54	
FS0225-38	225 Gallon	250	87		P	1 to 2		52 x 42 x 81 210#	38 x 52	
FS0325-38	325 Gallon	300	108		P	1 to 2		72 x 42 x 81 252#	38 x 72	
FS0335-44	335 Gallon	300	118		P	1 to 2		56 x 49 x 94 272#	44 x 56	
FS0510-57	510 Gallon Elliptical	300	164		P	1		80 x 40 x 62 202#	57 x 80 x 39	
FS0535-48	535 Gallon	300	162		P	1		48 x 78 x 58 200#	48 x 78	
FS0735-48	735 Gal Hoops Req.	300	252		P	1		103 x 48 x 59 292#	48 x 103	
FS0925-DW	925 Gal Hoops Req.	300	292		P	1		81 x 62 73 335#	62 x 81	
FS1005-48	1005 Gal Hoops Req.	300	342		CP	1		130 x 48 x 61 378#	48 x 130	
FS1035-78	1035 Gal Hoops Req. ELLIPTICAL	300	292		P	1		88 x 78 x 60 332#	78 x 90 x 52	
FS1065-56W	1065 Gal Hoops Req.	300	342		P	1		105 x 56 68 380#	56 x 105	
FS1300-DW	1300 Gal Hoops Req.	300	427		CP	1		114 x 62 x 72 505#	62 x 114	
FS1610-78	1610 Gal Hoops Req. ELLIPTICAL	300	530		CP	1		139 x 50 x 90 629#	78 x 139 x 56	
FS1750-62W	1750 Gal Hoops Req.	300	616		CP	1		147 x 62 x 71 620#	62 x 147	
FS1800-2W	1800 Gal Hoops Req.	300	580		P	1			62 x 149	12116 supports
FS1850-78	1850 Gal Hoops Req. ELLIPTICAL	300	571		CP	1			78 x 139 x 63	FIGURE AS 2 - 925'S FLAT/STEP
FS2350-88	2350 Gal Hoops Req. ELLIPTICAL	-	920						88 x 146 x 63	FLAT/STEP
FS2600-2W	2600 Gal Hoops Req.	-	850						62 x 212	FLAT/STEP
FS2750-88	2750 Gal Hoops Req. ELLIPTICAL	-	1150						88 x 146 x 70	FLAT/STEP
FS3250-88	3250 Gal Hoops Req. ELLIPTICAL	-	1208						88 x 146 x 79	FLAT/STEP
FS3750-88	3750 Gal Hoops Req. ELLIPTICAL	-	1422						88 x 146 x 91	FLAT/STEP
FS4200-92	4200 Gallon ELLIPTICAL	-	1648						92 X 195 X 80	FLAT/STEP
FS4250-88	4250 Gal Hoops Req. ELLIPTICAL	-	1617						88 x 146 x 101	Step Deck

FSxxxx-W = Without Sump

PART NO.	FREE STANDING HORIZONTAL WITH SUMP	CLASS	WGT	FSU	SINGLE QNTY	PLT QNTY		MAX PALLET DIMS	PROD DIMS	NOTES	
FM0025-16S	25 Gallon	250	15	FSU	BOX	6 to 12		57 x 40 x 65 208#	16 x 34	*IF SHIPPED W/OUT SKID	
FM0925-DS	925 Gal Hoops Req.	300	292		P	1		81 x 62 73 331#	62 x 81		
FM1010-48	1010 Gal Hoops Req.	300	342		CP	1		130 x 60 x 54 420#	48 x 130		
FM1065-56S	1065 Gal Hoops & Skid Req.	300	342		P	1		105 x 65 x 60 380#	56 x 105		
FM1300-DS	1300 Gal Hoops & Skid Req.	300	427		CP	1		114 x 70 x 67 465#	62 x 114		
FM1310-62	1310 Gallon*	300	500					10' - step deck, fb or var	62 x 114 x 67		
FM1610-78	1610 Gal Hoops & Skid Req. ELLIPTICAL	300	530		CP & TS1*	1		139 x 50 90 629#	78 x 139 x 58		
FM1750-62S	1750 Gal Hoops & Skid Req.	300	616		CP	1		147 x 70 68 620#	62 x 147		
FM1800-2S	1800 Gal Hoops & Skid Req.	300	580		P	1			62 x 149		FIGURE AS 2 - 925'S
FM1850-78	1850 Gal Hoops & Skid Req.	300	571		CP				78 x 139 x 63		FLAT/STEP
FM2350-88S	2350 Gal Hoops & Skid Req. ELLIPTICAL	-	920		TS2*				88 x 146 x 63		FLAT/STEP
FM2600-2S	2600 Gal Hoops & Skid Req.	-	850						62 x 212		FLAT/STEP
FM2750-88S	2750 Gal Hoops & Skid Req. ELLIPTICAL	-	1150		TS2*				88 x 146 x 70		FLAT/STEP
FM3200-2S	3200 Gal Hoops & Skid Req.	-	1100						88 x 172 x 74		FLAT/STEP - NO VAN
FM3250-88S	3250 Gal Hoops & Skid Req. ELLIPTICAL	-	1208		TS2*				88 x 146 x 79		FLAT/STEP
FM3750-88	3750 Gal Hoops & Skid Req. ELLIPTICAL	-	1422						88 x 146 x 91		FLAT/STEP
FM4200-92	4200 Gallon ELLIPTICAL	-	1648						92 X 195 X 80	FLAT/STEP	
FM4250-88	4250 Gal Hoops & Skid Req. ELLIPTICAL	-	1617						88 x 146 x 101	STEP	

FMxxxx-S= Sump

PART NO.	HOOPS AND SKIDS	CLASS	WGT	FSU	SINGLE QNTY	PLT QNTY	SETS	MAX PALLET DIMS	PROD DIMS	NOTES
FS048-HP	735 Gal Hoops	60	50		SW		Set of 3		1.315 OD	TANK/HOOP/SKID COMBINATIONS SHIP ASSEMBLED
FS062-HP-925	925 Gal Hoops	60	47		SW		Set of 2		1.66 OD	
FS062-HP-1300	1300 Gal Hoops	60	71		SW		Set of 3		1.66 OD	
FS062-HP-1750	1750 Gal Hoops	60	94		SW		Set of 4		1.66 OD	
FS062-HP-1800C	1800 Gal Hoops	60	94		SW		Set of 4		1.66 OD	
FS062-HP-2600C	2600 Gal Hoops	60	141		SW		Set of 6		1.66 OD	
FS0055-HP	55 Gal Hoops	60	9		SW		Set of 2		1.25 OD	
FS0510-HP	510 Gal Hoops	60	36		SW		Set of 3		1.315 OD	
FS1005-HP	1005 Gal Hoops	60	70		SW		Set of 4		1.315 OD	
FM1010-HP	1010 Gal Hoops	60	56		SW		Set of 4		1.315 OD	
FS1035-HP	1035 Gal Hoops	60	75		SW		Set of 3		1.66 OD	
FS1065-HP	1065 Gal Hoops	60	48		SW		Set of 3		1.315 OD	
FS1610-HP	1610 Gal Hoops w/o sump	60	118		SW	0	Set of 4		1.66 OD	
FM1610-HP	1610 Gal Hoops w/sump	60	112		SW	0	Set of 4		1.66 OD	
FS1850-HP	1850 Gal Hoops w/o sump	60	128		SW	0	Set of 4		1.66 OD	
FM1850-HP	1850 Gal Hoops w/sump	60	120		SW	0	Set of 4		1.66 OD	
FS2350-HP	2350 Gal Hoops	60	116		SW		Set of 4		1.90 OD	
FS2750-HP	2750 Gal Hoops	60	136		SW		Set of 4		1.90 OD	
FM3200-HP	3200 Gal Hoops	60	112		SW		Set of 4		1.66 OD	
FS3250-HP	3250 Gal Hoops	60	140		SW		Set of 4		1.90 OD	
FS3250-LAD	3250 Gal Ladder	70	46		P	1			16 x 78	
FS3750-HP	3750 Gal Hoops	60	400		SW	0	Set of 4		1.90 OD	
FS3750-LAD	3750 Gal Ladder	70	62		P	3			16 x 90	
FS4200-HP-92	4200 Gal Hoops	60	185		SW		Set of 5		1.90 OD	
FS4200-HPF-92	4200 Gal Hoops w/ feet	60	185		SW		Set of 5		1.90 OD	
FS4250-HP	4250 Gal Hoops	60	432		SW	0	Set of 4		1.90 OD	
FS4250-LAD	4250 Gal Ladder	70	68		P	3			16 x 100	
FS0925-SK	925 Gal Skid	150	280						61 x 64	
FM1010-SK	1010 Gal Skid	150	409						53 x 115	
FM1065-SKS	1065 Gal Skid w/sump	150	405						61 x 78	
FS1065-SKW	1065 Gal Skid w/o sump	150	200						59 x 100	
FS1300-SK	1300 Gal Skid	150	450						64 x 104	
FM1310-SKC	1310 Gal Skid Center Sump	150	450						64 x 105	
FM1310-SKE	1310 Gal Skid End Sump	150	450						64 x 100	
FM1610-SKC	1610 or 1850 Gal Skid w/c sump	150	490		CP	3			83 x 107	
FM1610-SKE	1610 or 1850 Gal Skid w/e sump	150	490		CP	3			83 x 112	
FS1610/1850-SK	1610 /1850 Skid	150	750						79 x 134.5	
FS1750-SK	1750 Gal Skid	150	604						64 x 138	
FM1800-SKS	1800 Gal Skid w/ sump	150	580						64 x 125	
FS1800-SKW	1800 Gal Skid w/o sump	150	382						64 x 125	
FM2350/3250-SKC	2350/2750/3250/3750/4250 Gal Skid w/c sump	150	1060						88 x 141	
FM2350/3250-SKE	2350/2750/3250/3750/4250 Gal Skid w/e sump	150	1060						88 x 141	
FS2350/3250-SK	2350/2750/3250/3750/4250 Gal Skid no sump	150	1078						88 x 141	
FS2600-SK	2600 Gal Skid	150	900						64 x 201	
FM3200-SK	3200 Gal Skid	150	1163						90 x 168	
FM4200-SKC	4200 Gal Skid Center Sump		1454						92 x 189	
FM4200-SKE	4200 Gal Skid End Sump		1454						92 x 189	
FS4200-SK	4200 Gal Skid w/o sump		1454						92 x 189	

PART NO.	BAFFLES		WGT	FSU	SINGLE QNTY	PLT QNTY	SETS	MAX PALLET DIMS	PROD DIMS	NOTES
FS1065-BAF	1065	Optional Baffle Kit	38							INSTALLED IN TANK
FS1300-BAF	1300	Optional Baffle Kit	35							
FS1750-BAF	1750	Optional Baffle Kit	70							
FS2600-BAF	2600	Optional Baffle Kit	70							

PART NO.	POWDER-COATED STEEL BANDS W/ J-BOLTS	CLASS	WGT	FSU	SINGLE QNTY			MAX PALLET DIMS	PROD DIMS	NOTES
FS0035-SB*	35 Gallon Kit Silver	60	3	FSU					2 x 45	BANDS ARE USUALLY SHIPPED INSIDE THE TANK.
FS0065-SB*	65 Gallon Kit Silver	60	4	FSU					2 x 61	
FS125/165-SBPJ	125/165 Gallon Kit Black	60	11	FSU					3 x 80	
FS225/325-SBPJ	225/325 Gallon Kit Black	60	13	FSU					3 x 95	
FS0335-SBPJ	335 Gallon Kit Black	60	15	FSU					3 x 110	
FS0535-SBPJ	535 Gallon Kit Black	60	16	FSU					3 x 120	

*FS0035 & FS0065 bands are stainless steel. Stainless is available on other sizes - call for quote

PART NO.	POWDER-COATED STEEL BANDS W/ FEET	CLASS	WGT	FSU	SINGLE QNTY			MAX PALLET DIMS	PROD DIMS	NOTES
FS0035-SBPF	35 Gallon Kit Black	60	8	FSU					2 x 47.5	BANDS ARE USUALLY SHIPPED ON THE TANK.
FS0065-SBPF	65 Gallon Kit Black	60	12	FSU					2 x 67	
FS125/165-SBPF	125/165 Gallon Kit Black	60	16	FSU					2.5 x 84.5	
FS225/325-SBPF	225/325 Gallon Kit Black	60	19	FSU					2.5 x 99.5	
FS0335-SBPF	335 Gallon Kit Black	60	34	FSU					2.75 x 116.5	
FS0535-SBPF	535 Gallon Kit Black	60	36	FSU					2.75 x 125	

PART NO.	ROUND HORIZONTAL TANKS	CLASS	WGT	FSU	SINGLE QNTY	PLT QNTY		MAX PALLET DIMS	PROD DIMS	NOTES
HZ0025-23	25 Gallon	250	16	FSU	SW	4 to 10		46 X 45 X 74 180#	23 x 22	
HZ0055-23	55 Gallon	250	25	FSU	BOX	4 to 7		46 X 40 97 201#	23 x 38	
HZ0075-24	75 Gallon	250	33	FSU	SW	3 to 7		47 X 48 98 257#	24 x 47	
HZ0095-24	95 Gallon	300	37	FSU	SW	3 to 7		56 x 48 98 299#	24 x 56	
HZ0100-23	100 Gallon	250	40	S	SW	3 to 5		64 x 46 74 240#	23 x 64	
HZ0110-30	110 Gallon	300	42	S	SW	3 to 5		60 x 44 x 95 240#	30 x 44	
HZ0150-30	150 Gallon x 30	300	50		SW	3 to 5		60 x 57 x 95 280#	30 x 57	
HZ0150-32	150 Gallon x 32	300	50		SW	3 to 4		64 x 52 x 69 232#	32 x 52	
HZ0200-32	200 Gallon x 32	300	66		SW				32 x 68	
HZ0200-38	200 Gallon x 38	300	66		SW				38 x 51	
HZ0300-38	300 Gallon	300	90		SW				38 x 76	
HZ0400-42	400 Gallon	300	117		SW	1			42 x 76	
HZ0500-48	500 Gallon	300	124		SW				48 x 79	

PART NO.	HORIZONTAL CRADLES	CLASS	WGT	FSU	SINGLE QNTY			MAX PALLET DIMS	PROD DIMS	NOTES
HZ0025-C	25 Gallon	150	18	FSU	BOX				1.5" x 50"	
HZ0055-C	55 Gallon	150	24	FSU	BOX				2" x 50.5"	
HZ0075-C	75 Gallon	150	36	FSU	SW				2" x 51.5"	
HZ0095-C	95 Gallon	150	38	FSU	SW				2" x 51.5"	
HZ0100-C	100 Gallon	150	40	FSU	SW				1.75" x 41.50"	
HZ0110-C	110 Gallon	150	40	FSU	SW				2.75" x 60"	
HZ0153-C	150 Gallon x 30	150	57	FSU	SW				2.75" x 55"	
HZ0150-C	150 Gallon x 32	150	56	FSU	SW				2.75" x 56"	
HZ0232-C	200 Gallon x 32	150	110	FSU	SW				2.75" x 57"	
HZ0238-C	200 Gallon x 38	150	85		SW				2.75" x 65"	
HZ0300-C	300 Gallon	150	145		SW				2.75" x 69.5"	
HZ0400-C	400 Gallon	150	146		SW				2.75" x 76"	
HZ0500-C	500 Gallon	150	170		SW				2.75" x 88"	

HZ cradles usually ship assembled with the tank

PART NO.	ELLIPTICAL TANKS	CLASS	WGT	FSU	SINGLE QNTY	PLT QNTY		MAX PALLET DIMS	PROD DIMS	NOTES
HE0085-36	85 Gallon tank	250	42	FSU	SW	2		47 x 45 x 40	36 x 47 x 21	
HE0200-41	200 Gallon tank	250	84		P	1		58 x 41 x 70 204#	41 x 66 x 26	
HE0300-48	300 Gallon	300	114		P	1		48 x 40 x 75 152#	48 x 70 x 30	

PART NO.	ELLIPTICAL TANKS cont.	CLASS	WGT	FSU	SINGLE QNTY	PLT QNTY		MAX PALLET DIMS	PROD DIMS	NOTES
HE0400-57	400 Gallon	300	129		P	1		57 x 40 x 75 169#	57 x 70 x 36	Shipped in Tank
HE0500-57	500 Gallon	300	167		P	1		57 x 40 x 87 205#	57 x 82 x 36	
HED0500-57	500 Gallon Deep (8.5") Sump	300	167		P	1		57 x 46 x 87 205#	57 x 82 x 36	
HE0600-64	600 Gallon	300	187		P	1		84 x 64 x 51 478#	64 x 84 x 46	
HE0750-69	750 Gallon	300	222		P	1		70 x 48 x 94 260#	69 x 89 x 42	
HED0750-69	750 Gallon Deep (8.5") Sump	300	222		P	1		70 x 56 x 94 260#	69 x 89 x 42	
HE0850-69	850 Gallon	300	248		P	1		70 x 52 x 93 286#	69 x 89 x 46	
HED0850-69	850 Gallon Deep (8.5") Sump	300	248		P	1		70 x 60 x 93 286#	69 x 89 x 46	
HE1000-78	1000 Gallon	300	287		CP	1		78 x 54 x 96 325#	78 x 90 x 49	
HED1000-78	1000 Gallon Deep (8.5") Sump	300	287		CP	1		78 x 62 x 96 325#	78 x 90 x 49	
HE1000-BAF	1000 Optional Baffle Kit	-	41							
HE1250-78	1250 Gallon	300	402		CP	1		78 x 64 x 97 410#	78 x 92 x 60	
HED1250-78	1250 Gallon Deep (8.5") Sump	300	402		CP	1		78 x 72 x 97 410#	78 x 92 x 60	
HE1600-78	1600 Gallon	300	439		CP & TS1 *	1		138 x 50 x 90 629#	78 x 138 x 49	
HED1600-78	1600 Gallon Deep (6") Sump	300	439		CP & TS1 *	1		138 x 54 x 90 629#	78 x 138 x 49	

PART NO.	ELLIPTICAL CRADLES	CLASS	WGT	FSU	SINGLE QNTY	PLT QNTY		MAX PALLET DIMS	BANDS	NOTES
HE0085-C	85 Gallon	150	40		P	1			2" x 55	
HE0200-C	200 Gallon	150	140		P	1			3" x 61"	
HE0300-C	300 Gallon	150	155		P	1			3" x 74"	
HE0400-C	400 Gallon	150	190		P	1			4" x 89"	
HE0500-C	500 Gallon	150	202		P	1			4" x 89"	
HE0600-C	600 Gallon	150	243		P	1			4" x 92"	
HE0750-C	750 Gallon	150	405		P	1			4" x 92"	
HE0850-C	850 Gallon	150	408		P	1			4" x 99"	
HE1000-C	1000 Gallon	150	515		P	1			4" x 105"	
HE1250-C	1250 Gallon	150	520		P	1			4" x 126"	
HE1600-C	1600 Gallon	150	578		CP	1			3.5" x 124"	

PART NO.	CONE BOTTOM TANKS - FLAT TOP	CLASS	WGT	FSU	SINGLE QNTY	PLT QNTY		MAX PALLET DIMS	PROD DIMS	NOTES
CB0150-36	150 Gallon-45 deg	300	63		*				36 x 51	* TANK ONLY SHIP CB
CB0200-42	200 Gallon-45 deg	300	77		*				42 x 55	* TANK/STAND SHIP SW AS ONE PIECE
CBFD240-42	240 Gallon Full Drain-45 deg	300	77		*				42 x 59	
CB0295-52	295 Gallon-45 deg	300	97		*				52 x 51	
CB0345-52	345 Gallon-45 deg	300	102		*				52 x 58	
CB0350-42	350 Gallon-45 deg	300	120		*				42 x 81	
CB0500-52	500 Gallon-45 deg	300	132		*				52 x 81	
CB0750-52	750 Gallon-45 deg	300	171		x				52 x 105	
CB0850-90	850 Gallon-15 deg	400	212		*				91 x 56	
CB1150-90	1150 Gallon-15 deg	400	242		*				91 x 67	
CB1550-90	1550 Gallon-30 deg	400	286		*				91 x 88	
CB2450-90	2450 Gallon-15 deg	400	437		x				91 x 114	
CB2550-90	2550 Gallon-30 deg	400	502		x				91 x 126	

PART NO.	CONE BOTTOM TANKS - DOME TOP	CLASS	WGT	FSU	SINGLE QNTY	PLT QNTY		MAX PALLET DIMS	PROD DIMS	NOTES
CB0300-42	300 Gallon-45 deg	300	102		*				42 x 67	* TANK ONLY SHIP CB
CB0800-86	800 Gallon-15 deg	400	182		*				86 x 48	* TANK/STAND SHIP SW AS ONE PIECE
CB1000-64	1000 Gallon-45 deg	300	252		x				64 x 98	
CB1000-90	1000 Gallon-15 deg	400	212		*				91 x 54	
CB1200-90	1200 Gallon-15 deg	400	242		*				91 x 62	
CB1300-90	1300 Gallon-15 deg	400	262		*				91 x 65	
CB1490-64	1490 Gallon-45 deg	300	342		x				64 x 132	
CB1500-96	1500 Gallon-30 deg	400	252		x				96 x 80	
CB1600-90	1600 Gallon-30 deg	400	286		x				91 x 85	

PART NO.	CONE BOTTOM TANKS - DOME TOP continued	CLASS	WGT	FSU	SINGLE QNTY			MAX PALLET DIMS	PROD DIMS	NOTES
CB1700-86	1700 Gallon-15 deg	400	286		*				86 x 85	VAN FLAT/ STEP
CB1750-90	1750 Gallon-15 deg	-	308		x				91 x 82	
CB2000-96	2000 Gallon-30 deg	-	292						96 x 96	
CB2495-90	2495 Gallon-30 deg	400	487		x				91 x 119	
CB2500-90	2500 Gallon-15 deg	400	437		x				91 x 111	
CB2600-90	2600 Gallon-30 deg	400	502		x				91 x 123	
CB2600-86	2600 Gallon-45 deg	400	502		x				86 x 146	
CB3000-90	3000 Gallon-15 deg	400	552		x				91 x 128	
CB3000-96	3000 Gallon-30 deg	-	552						96 x 125	
CB4200-122	4200 Gallon-15 deg	-	1102						122 x 113	
CB4600-102	4600 Gallon-15 deg	-	1202						102 x 155	
CB4900-102	4900 Gallon-15 deg	-	1302						102 x 159	
CB6000-122	6000 Gallon-15 deg	-	1602						122 x 150	
CB6900-122	6900 Gallon-15 deg	-	1702						122 x 168	
CB7500-142	7500 Gallon-15 deg		1677						142 x 163	
CB8250-122	8250 Gallon-15 deg	-	2102						122 x 195	
CB8250-122	8250 Gallon-15 deg	-	2102						122 x 195	
CB10500-142	10500 Gallon-15 deg		2502						142 x 209	
CB12500-142	12500 Gallon-15 deg		3402						142 x 239	

PART NO.	CONE BOTTOM STANDS	CLASS	WGT	FSU	SINGLE QNTY	PLT QNTY	CLEARANCE	MAX PALLET DIMS	PROD DIMS	NOTES
CB036-45ST	150 gal-45 deg	150	63			2	12"	40 x 36 71 166#	27 x 29 x 36	FLAT/STEP STEP STEP
CB042-45ST	200, 300 or 350 gal-45 deg	150	82			2	11"	42 x 42x 73 204#	36 x 36 x 43	
CBFD042-45ST	240 gal-45 deg full drain	150	82			2	10"	42 x 42 x 75 204#	34 x 34 x 42	
CB052-45ST	345 or 500 gal-45 deg	150	174				13"		42 x 42 x 55	
CB064-45ST	1000 or 1490 gal-45 deg	150	320				14"		64 x 64 x 64	
CB086-15ST	800 or 1700 gal-15 deg	150	360				11"		88 x 88 x 23	
CB086-45ST	2600 gal-45 deg	150	580				12"		88 x 88 x 49	
CB090-15ST	850, 1000, 1150, 1200, 1300, 1750, 2450, 2500, 2975 or 3000 gal-15 deg	150	380				11"		93 x 93 x 23	
CB090-30ST	1550, 1600, 2495, 2550 or 2600 gal-30 deg	150	640				9"		95 x 95 x 40	
CB096-30ST	1500, 2000, or 3000 gal 30 deg	150	553				12"		96 x 96 x 38	
CB102-15ST	4600 or 4900 gal-15 deg	150	640				11"		105 x 105 x 26	
CB122-15ST	4200, 6000, 6900 or 8250 gal-15 deg	150	1020				10"		122 x 122 x 27	
CB142-15ST	7500, 10500 or 12500 gal-15deg		1858				20"			

PART NO.	CONE BOTTOM TANKS - OPEN TOP	CLASS	WGT	FSU	SINGLE QNTY	PLT QNTY		MAX PALLET DIMS	PROD DIMS	NOTES
OC0840-90	840 Gallon - 15 deg with bolt-on top	400	214		CB				96 x 49	*TANK & STAND SHIP AS 2 PCS, TANK CB
OC1010-64	1010 Gallon - 45 deg with bolt-on top	400	252		x				70 x 99	
OC1050-90	1050 Gallon - 15 deg with bolt-on top	400	242		x				96 x 57	
OC1150-90	1150 Gallon - 15 deg with bolt-on top	400	262		x				96 x 60	
OC1450-90	1450 Gallon - 30 deg with bolt-on top	400	286		x				96 x 80	
OC1500-64	1500 Gallon - 45 deg with bolt-on top	400	342		x				70 x 134	
OC1710-86	1710 Gallon - 15 deg with bolt-on top	400	286		*				91 x 87	
OC2350-90	2350 Gallon - 15 deg with bolt-on top	400	437		x				96 x 106	
OC2440-90	2440 Gallon - 30 deg with bolt-on top	400	502		x				96 x 118	
OC2610-86	2610 Gallon - 45 deg with bolt-on top	400	502		x				91 x 147	

PART NO.	CONE BOTTOM TANKS - OPEN TOP STANDS	CLASS	WGT	FSU	SINGLE QNTY	PLT QNTY	CLEARANCE	MAX PALLET DIMS	SHIPPING DIMS	NOTES
CB064-45ST	1010 or 1500 gal-45 deg	150	320				14"		64 x 64 x 64	
CB086-15ST	1710 gal-15 deg	150	360				11"		88 x 88 x 23	
CB086-45ST	2610 gal-45 deg	150	580				12"		88 x 88 x 49	
CB090-15ST	840, 1050, 1150, or 2350 gal-15 deg	150	380				11"		93 x 93 x 23	
CB090-30ST	1450 or 2440 gal-30 deg	150	640				9"		95 x 95 x 40	

PART NO.	INDUCTOR TANKS	CLASS	WGT	FSU	SINGLE QNTY	PLT QNTY	MAX/PLT	MAX PALLET DIMS	PROD DIMS	NOTES
INFD7-15	7 Gallon Full Drain	250	8	FSU	Box	24		40 x 48 x 65 232#	15 x 21	pallet dims tank/stand or only tank * TANKS IN STAND SHIPS AS ONE PIECE WITH SW
INFD10-15	10 Gallon Full Drain	250	10	FSU	Box	20		40 x 48 x 65 230#	15 x 25	
IN0015-19	15 Gallon	250	12	FSU	BOX*	4 to 16 tanks	8 tanks & stan	40 x 48 x 75 232#	19 x 24	
INFD15-19	15 Gallon Full Drain	250	12	FSU	BOX*	4 to 16 tanks	8 tanks & stan	40 x 48 x 75 232#	19 x 27	
IN0015-19SM	15 Gallon Side Mount	250	10	FSU	BOX*	4 to 16 tanks	8 tanks & stan	40 x 48 x 75 232#	19 x 24	
IN0030-24	30 Gallon	300	17	FSU	SW*	4 to 12 tanks	8 tanks & stan	48 x 48 x 80 244#	24 x 30	
INFD30-24	30 Gallon Full Drain	300	17	FSU	SW*	4 to 12 tanks	12 tanks & st	48 x 48 x 86 254#	24 x 33	
INFD40-30	40 Gallon	300	26	FSU	SW*		3 tanks & sta	36 x 40 x 89 134#	30 x 34	
IN0055-24	55 Gallon x 24	300	24	FSU	SW*	4 to 8 tanks	4 tanks & stan	48 x 48 x 90 232#	24 x 42	
INFD55-24	55 Gallon x 24 Full Drain	300	24	FSU	SW*	4 to 8 tanks	*	48 x 48 x 90 232#	24 x 46	
INFD60-30	60 Gallon x 30 Full Drain	300	28	FSU	SW*	4 tanks	*	60 x 40 65 144#	30 x 38	
IN0085-30	85 Gallon	300	37	FSU	SW*	4 tanks	*	60 x 48 x 65 188#	30 x 43	
INFD85-30	85 Gallon Full Drain	300	37	FSU	SW*	4 tanks	*	60 x 48 x 65 188#	30 x 48	
IN0110-30	110 Gallon	300	44	S	SW*	4 tanks	*	60 x 57 x 65 216#	30 x 51	
INFD110-30	110 Gallon	300	44	S	SW*	4 tanks	*	60 x 57 x 65 216#	30 x 56	

PART NO.	BLOW-MOLDED INDUCTOR TANK SETS	CLASS	WGT	FSU	SINGLE QNTY	PLT QNTY		MAX PALLET DIMS	BOX DIMS	NOTES
IBFD10-SET	10 Gallon Full Drain w/ Poly Legs	250	20	FSU	BOX	2 to 10		40 x 48 x 88	19 x 22 x 33	
IBFD15-SET	15 Gallon Full Drain w/ Poly Legs	250	23	FSU	BOX	2 to 10		40 x 48 x 88	19 x 22 x 33	
IBFD20-SET	20 Gallon Full Drain w/ Poly Legs	250	24	FSU	BOX	2 to 10		40 x 48 x 88	19 x 22 x 33	
IBFD35-SET	35 Gallon Full Drain w/ Poly Legs	250	41	FSU	BOX	2 to 8		48 x 48 x 90 430#	25 x 25 x 43	
IBFD60-SET	60 Gallon Full Drain w/ Poly Legs	250	47	FSU	BOX	2 to 6		48 x 55 x 84 370#	25 x 25 x 55	
12695	Leg Anchor Kit for Blow Molded Inductors	70	2	FSU	BOX				6 x 6 x 6	

PART NO.	INDUCTOR STANDS	CLASS	WGT	FSU	SINGLE QNTY	PLT QNTY		MAX PALLET DIMS		NOTES
INFD7/10-ST	7 or 10 Gal	150	12	FSU	BOX	9		51 x 40 x 74 158#		
IN15-ST	15 gal	150	15	FSU	BOX or SW	4 to 11		42 x 42x 75 205#		
INFD15-ST	15 gal (4" taller for Full Drain tank)	150	16	FSU	SW	4 to 11		42 x 42x 83 216#		
IN30/55-ST	30 or 55 (24") gal	150	18	FSU	SW	4 to 11		48 x 48 x 87 238#		
INFD30/55-ST	30 or 55 (24") gal (4" taller for Full Drain tank)	150	19	FSU	SW	4 to 11		48 x 48 x96 238#		
IN40/85-ST	40, 60 (30"), 85 or 110 gal	150	40	FS	SW	5		56 x 40 x 92 240#		
INFD40-ST	40 gal only (designed for UPS shipments)	150	40	FSU	SW					

PART NO.	VERTICAL BATCH TANKS	CLASS	WGT	FSU	SINGLE QNTY	PLT QNTY		MAX PALLET DIMS	SHIP DIMS	NOTES
VT0055-23	55 Gallon	300	26	FSU	CB	6		48 x 40 x 74 196#	27 x 38	
VT0100-23	100 Gallon	300	36		CB	4		50 x 50 x 72 184\$	27 x 64	
VT0145-36	145 Gallon	300	52		CB				40 x 40	
VT0200-36	200 Gallon	300	58		CB				40 x 53	
VT0250-36	250 Gallon	300	76		CB				40 x 62	
VT0325-36	325 Gallon	300	92		CB				40 x 81	

PART NO.	VERTICAL BATCH TANKS - OPEN TOP	CLASS	WGT	FSU	SINGLE QNTY	PLT QNTY		MAX PALLET DIMS	SHIP DIMS	NOTES
OP0055-23	55 Gallon	300	26	FSU	CB	6		52 x 40 75 196#	27 x 36	
OP0100-23	100 Gallon	300	36		CB	6		51 x 51 x 70 184#	27 x 62	
OP0145-36	145 Gallon	300	52		CB				40 x 39	
OP0200-36	200 Gallon	300	58		CB				40 x 51	
OP0250-36	250 Gallon	300	76		CB				40 x 61	
OP0325-36	325 Gallon	300	92		CB				40 x 80	

PART NO.	CONE BOTTOM BATCH TANKS	CLASS	WGT	FSU	SINGLE QNTY	PLT QNTY		MAX PALLET DIMS	SHIP DIMS	NOTES
CB0055-23	55 Gallon	300	26	FSU	CB	6		52 x 44 x 75 196#	27 x 39	* TANK ONLY SHIP CB
CB0100-23	100 Gallon	300	36		CB	6		63 x 52 x 75 220#	27 x 65	
CB0145-36	145 Gallon	300	52		CB	*			40 x 43	
CB0200-36	200 Gallon	300	58		CB	*			40 x 55	
CB0250-36	250 Gallon	300	76		CB	*			40 x 67	
CB0325-36	325 Gallon	300	92		CB	*			40 x 84	
PART NO.	CONE BOTTOM BATCH TANKS - OPEN TOP	CLASS	WGT	FSU	SINGLE QNTY	PLT QNTY		MAX PALLET DIMS	SHIP DIMS	NOTES
OC0055-23	55 Gallon	300	26	FSU	CB	6		52 x 44 x 75 196#	27 x 37	* TANK ONLY SHIP CB
OC0100-23	100 Gallon	300	36		CB	4		63 x 52 x 75 220#	27 x 63	
OC0145-36	145 Gallon	300	52		CB	*			40 x 41	
OC0200-36	200 Gallon	300	58		CB	*			40 x 53	
OC0250-36	250 Gallon	300	76		CB	*			40 x 65	
OC0325-36	325 Gallon	300	92		CB	*			40 x 82	

PART NO.	BATCH TANKS LIDS & STANDS	CLASS	WGT	FSU	SINGLE QNTY	PLT QNTY	CLEARANCE	MAX PALLET DIMS	PROD DIMS	NOTES
19502	23" Hinged Lid	150	8	FSU	BOX				15 x 8 x 27	
19505	36" Hinged Lid	250	14	FSU	BOX				23 x 8 x 40	
OC023-STP	Poly stand for 23" dia CB&OC	250	45	FSU		4	19"		30 x 28	
19506	23" Vertical Stand Adaptor	150	7	FSU	SW				23 x 5	
OC036-STP	Poly stand for 36" dia CB&OC	250	92			2	19"		44 x 30	
19507	36" Vertical Stand Adaptor	250	15	FSU					36 x 6	
CB023-15ST	55 or 100 gal-15 deg	150	37	FSU	SW	12	13"	48 x 36 x 69 484#	18 x 20 x 24	
CB036-15ST	145, 200, 250 or 325 gal-15 deg	150	84	FSU	SW	4	12"	48 x 42 67 376#	28 x 31 x 26	

PART NO.	CONTAINMENT TANKS - OPEN TOP	CLASS	WGT	FSU	SINGLE QNTY	PLT QNTY		MAX PALLET DIMS	PROD DIMS	NOTES
OP0055-2DC	55 Gal Drum Containment 2 drum	250	70		P	1 to 3			34 x 62 x 26	*SHIPPED ON CUSTOM PALLET WHEN SHIPPED IN QUANTITIES OF 6 OR
OP0100-RT	100 Gallon Rectangle	300	26		SW	6 - 25*		43 x 43 x 70 690#	43 x 43 x 17	
OP0150-RT	150 Gallon Rectangle	300	35		SW	6 - 15*		47 x 60 x 49 530#	47 x 60 x 16	
OP0155-28	155 Gallon	300	45		SW				28 x 65	
OP0200-RT	200 Gallon Rectangle	250	78		SW				66 x 78 x 12	
OP0205-31	205 Gallon	300	54		SW				31 x 70	
OP0210-RT	210 Gallon Rectangle	300	52		SW	6 - 20*			53 x 65 x 18	
OP0210-40	210 Gallon	300	48		CB				40 x 42	
OP0245-31	245 Gallon	300	61		SW				31 x 80	
OP0300-RT	300 Gallon Rectangle	300	82		SW				58 x 95 x 18	
OP0325-RT	325 Gallon Rectangle	300	115		CP	1 to 5		97 x 70 x 65 525#	60 x 96 x 24	
OP0360-48	360 Gallon	300	115		CB				53 x 51	
OP0425-RT	425 Gallon Rectangle	300	94		SW				71 x 69 x 25	
OP0500-56	500 Gallon with bolt-on top	300	150		CB				62 x 65	
OP0625-RT	625 Gallon Rectangle	300	145		CP	1 to 5		109 X 43 X 81 695#	72 x 108 x 24	
OP0635-64	635 Gallon with bolt-on top	400	102		CB				70 x 53	
OP0825-RT	825 Gallon Rectangle	300	276		CB	1 to 3			73 x 73 x 66	
OP0900-86	900 Gallon	400	175		CB				86 x 43	
OP1000-74	1000 Gallon with bolt-on top	300	277		CB				84 x 64	
OP1010-64	1010 Gallon with bolt-on top	300	252		CB	0			70 x 84	
OP1060-86	1060 Gallon with bolt-on top	400	192		CB				91 x 56	
OP1200-86	1200 Gallon	400	200		CB				86 x 54	
OP1210-64	1210 Gallon with bolt-on top	400	277		CB	0			70 x 100	
OP1325-RT	1325 Gallon Rectangle	300	360						84 x 84 x 60	
OP1350-86	1350 Gallon	400	217		CB				86 x 62	
OP1360-86	1360 Gallon with bolt-on top	400	230		CB				91 x 67	
OP1500-86	1500 Gallon	400	240		CB				86 x 68	
OP1505-64	1505 Gallon with bolt-on top	300	337		CB	0			70 x 117	

PART NO.	CONTAINMENT TANKS - OPEN TOP	CLASS	WGT	FSU	SINGLE QNTY	PLT QNTY		MAX PALLET DIMS	PROD DIMS	Notes
OP1510-86	1510 Gallon with bolt-on top	400	252		CB				91 x 71	(2) SB if shipped with out lid and tank inside (2) BR if shipped with out lid and no tank inside
OP1660-86	1660 Gallon with bolt-on top	400	280		CB				91 x 76	
OP1700-90	1700 Gallon	300	317		CB				91 x 66	
OP1825-RT	1825 Gallon Rectangle	300	520		CB				96 x 96 x 62	
OP2000-RT	2000 Gallon Rectangle	300	570						96 x 96 x 68	
OP2010-64	2010 Gallon with bolt-on top	300	465		CB	0			70 x 158	
OP2060-86	2060 Gallon with bolt-on top	400	402		CB				91 x 95	
OP2200-90	2200 Gallon	400	365		CB				91 x 85	
OP2700-90	2700 Gallon	-	480						91 x 103	
OP3300-102	3300 Gallon	-	550		(2) BR or (2) SB*				102 x 105	
OP3700-96	3700 Gallon	-	625		(2) BR				98 x 128	
OP6800-120	6800 Gallon	-	1525		(2) BR or (2) SB*				122 x 146	

PART NO.	DOUBLE WALL VERTICAL TANKS	CLASS	WGT	FSU	SINGLE QNTY	PLT QNTY		MAX PALLET DIMS	SHIPPING DIMS	NOTES
DW0065-28	65 Gallon	250	52		CB				29 x 44	FLAT/STEP FLAT/STEP FLAT/STEP FLAT/STEP FLAT/STEP FLAT/STEP FLAT/STEP FLAT/STEP FLAT/STEP FLAT/STEP FLAT/STEP FLAT/STEP
DW0120-36	120 Gallon	250	81		CB				36 x 50	
DW0150-36	150 Gallon	250	99		CB				36 x 60	
DW0300-57	300 Gallon	250	190		CB				58 x 45	
DW0500-527	500 Gallon	300	264		P	1			58 x 69	
DW1000-77	1000 Gallon	300	552		P	1			77 x 82	
DW1500-77	1500 Gallon	-	673						77 x 119	
DW2000-102	2000 Gallon	-	907						102 x 97	
DW2500-102	2500 Gallon	-	1153						102 x 119	
DW3000-102	3000 Gallon		1512						102 x 141	
DW3500-102	3500 Gallon		1707						102 x 164	
DW6000-120	6000 Gallon		3001						120 x 191	
DW6500-120	6500 Gallon		3202						120 x 207	

PART NO.	FUEL TANKS	CLASS	WGT	FSU	SINGLE QNTY	PLT QNTY		MAX PALLET DIMS	PROD DIMS	NOTES
SP0006-FU	6 Gal Fuel XLPE	150	5	FSU	BOX	20 to 80			10 x 15 x 10	
SP0006-FUWB	6 Gal Fuel XLPE w/1/4" brass bulkhead	150	5	FSU	BOX	20 to 80			10 x 15 x 10	
SP0012-FU	12 Gal Fuel XLPE	150	9	FSU	BOX	6 to 24			14 x 18 x 12	
SP0012-FUWB	12 Gal Fuel XLPE w/1/4" brass bulkhead	150	9	FSU	BOX	6 to 24			14 x 18 x 12	

PART NO.	STOCK TANKS	CLASS	WGT	FSU	SINGLE QNTY	PLT QNTY		MAX PALLET DIMS	PROD DIMS	NOTES
ARM-10115	RE124 50 Gallon Oval	300	15	FSU	SW	3 to 15		54 x 40 x 59 265#	55 x 31 x 12	SWING DOOR VAN
ARM-10116	RE224 100 Gallon Oval	300	25		SW	3 to 10		55 x 40 x 57 290#	55 x 31 x 25	
ARM-19455	R42 120 Gallon Round	300	30		SW	3 to 10		48 x 48 x 75 340#	48 x 24	
ARM-10117	RE226 150 Gallon Oval	300	46		SW	3 to 10		75 x 40 x 57 500#	76 x 31 x 25	
ARM-10138	R62 320 Gallon Round	400	62		SW	3 to 10		72 x 72 x 75 660#	72 x 24	
ARM-10139	R82 610 Gallon Round	400	92		SW	5/stack			96 x 24	
ARM-10135	R92 920 Gallon Round	400	137		SW	3/stack			106 x 29	

PART NO.	PICKUP TANKS	CLASS	WGT	FSU	SINGLE QNTY	PLT QNTY		MAX PALLET DIMS	PROD DIMS	NOTES
PU0200-52	200 Gallon	300	56		CB				52 x 30	
SSPU0200-70	200 Gallon Space Saver	250	120		P	1 to 3		70 x 42 x 34 170#	70 x 29 x 42	
PU0205-52	205 Gallon Low Profile	250	87		P	1 to 3		52 x 52 x 83 301#	52 x 52 x 26	
SSPU0300-70	300 Gallon Space Saver	250	174		P	1 to 3		70 x 42 x 46 224#	70 x 41 x 42	
PU0305-60	305 Gallon Low Profile	300	107		P	1 to 3		60 x 60 x95 361#	60 x 58 x 30	
PU0350-62	350 Gallon	300	94		CB				62 x 34	
SSPU0400-70	400 Gallon Space Saver	250	202		P	1		70 x 42 x 57 252#	70 x 52 x 42	
PU0450-62	450 Gallon	300	104		CB				62 x 41	

PART NO.	CROP CARE TANKS*	CLASS	WGT	FSU	SINGLE QNTY	PLT QNTY		MAX PALLET DIMS	PROD DIMS	NOTES
CM0500-48	500 Gal w/ box sump	250	202		P	1			48 x 90 x 38	CC TANKS SHIP ON A RETURNABLE PLASTIC PALLET
CM0750-48	750 Gal w/ box sump	250	262		P	1			48 x 90 x 50	
CC1000-58S	1000 Gal w/ sloped sump	300	345		P	1			58 x 115 x 47	
CC1000-58N	1000 Gal narrow bottom w/ sloped sump	300	345		P	1			58 x 115 x 51	
CM1000-58B	1000 Gal w/ box sump	300	350		P	1			58 x 115 x 47	
CC1250-58S	1250 Gal w/ sloped sump	250	480		P	1			58 x 115 x 57	
CC1250-58N	1250 Gal narrow bottom w/ sloped sump	250	480		P	1			58 x 115 x 61	
CM1250-58B	1250 Gal w/ box sump	250	485		P	1			58 x 115 x 57	
CC1500-58S	1500 Gal w/ sloped sump	250	550		P	1			58 x 115 x 66	
CC1500-58N	1500 Gal narrow bottom w/ sloped sump	250	550		P	1			58 x 115 x 70	
CM1500-58B	1500 Gal w/ box sump	250	550		P	1			58 x 115 x 66	

* Baffles & Rinse Tank included

PART NO.	CROP CARE HOOPS	CLASS	WGT	FSU	SINGLE QNTY			MAX PALLET DIMS	PROD DIMS	NOTES
CC0500-HPS	500 Gal Hoop (1 HOOP)	60	14		*				1-2/3" pipe	HOOPS SHIP ON A CUSTOM RACK - SINGLE SET ARE SW IF SHIPPED SEPARATE
CC0750-HPS	750 Gal Hoop (1 HOOP)	60	18		*				1-2/3" pipe	
CC1000-HP	1000 Gal Hoops	60	96		*				(3) 2-3/8" pipes	
CC1250-HP	1250 Gal Hoops	60	111		*				(3) 2-3/8" pipes	
CC1500-HP	1500 Gal Hoops	60	205		*				(5) 2-3/8" pipes	

PART NO.	OVAL TANK	CLASS	WGT	FSU	SINGLE QNTY	PLT QNTY		MAX PALLET DIMS	PROD DIMS	NOTES
OT0300-31	300 Gal Oval	250	102		P	1 to 2			31 x 49 x 56	

PART NO.	OVAL CRADLE	CLASS	WGT	FSU	SINGLE QNTY	PLT QNTY		MAX PALLET DIMS	PROD DIMS	NOTES
OT0300-C	300 Gal Oval Cradle	150	140		P	1 to 2			2.5" x 79"	

PART NO.	CUT-A-WAY TANKS	CLASS	WGT	FSU	SINGLE QNTY	PLT QNTY		MAX PALLET DIMS	PROD DIMS	NOTES
CAW0200-24	200 Gallon	250	82		P	1 to 3			24 x 55 x 46	
CAW0250-24	250 Gallon	250	97		P	1 to 3			24 x 61 x 51	

PART NO.	CUT-A-WAY CRADLES	CLASS	WGT	FSU	SINGLE QNTY	PLT QNTY		MAX PALLET DIMS	BANDS	NOTES
CAW0200-C	200 Gallon	150	135		P	2 w/ tank			3 x 60; 3 x 40	
CAW0250-C	250 Gallon	150	143		P	2 w/ tank			3 x 72; 3 x 51	

PART NO.	TEAR DROP TANKS	CLASS	WGT	FSU	SINGLE QNTY	PLT QNTY		MAX PALLET DIMS	PROD DIMS	NOTES
TD0250-36	250 Gal Tear Drop	300	97		P	1 to 2			36 x 52 x 45	
TD0300-36	300 Gal Tear Drop	300	109		P	1 to 2			36 x 62 x 45	

PART NO.	TEAR DROP CRADLES	CLASS	WGT	FSU	SINGLE QNTY	PLT QNTY		MAX PALLET DIMS	BANDS	NOTES
TD0250-C	250 Gal Tear Drop Cradle	150	96		P	1			2.5" x 74.5"	
TD0300-C	300 Gal Tear Drop Cradle	150	108		P	1			2.5" x 74.5"	

PART NO.	UTILITY TANKS - FLAT BOTTOM	CLASS	WGT	FSU	SINGLE QNTY	PLT QNTY		MAX PALLET DIMS	PROD DIMS	NOTES
SP0026-RT	26 Gal Rectangle	250	15	FSU	BOX	5 to 20			18 x 25 x 19	
SP0045-AS	45 Gal Rectangle	250	23	FSU	BOX	2 to 10			18 x 37 x 22	
SP0050-RT	50 Gal Rectangle	250	27	FSU	BOX	2 to 10			19 x 38 x 23	
SP0055-MM	55 Gal Rectangle	250	32	FSU	SW	2 to 10			18 x 18 x 45	
SP0080-RT	80 Gal Rectangle Support Req.	250	42	FSU	SW	2 to 10			18 x 27 x 45	
SP0100-RT	100 Gal Rectangle	250	50	FSU	SW	2 to 6			27 x 43 x 29	
SP0150-RT	150 Gal Rectangle	250	62		P	1 to 4			36 x 48 x 29	
SP0200-RT	200 Gal Rectangle	250	82		P	1 to 2			36 x 48 x 38	

PART NO.	UTILITY TANKS - FLAT BOTTOM continued	CLASS	WGT	FSU	SINGLE QNTY	PLT QNTY		MAX PALLET DIMS	PROD DIMS	NOTES
SP0250-UT	250 Gal Upright Rectangle	250	115		P	1 to 3			29 x 62 x 42	
SP0300-UT	300 Gal Upright Rectangle	250	159		P	1 to 3			29 x 62 x 53	
SP0400-UT	400 Gal Upright Rectangle	250	209		P	1 to 3			29 x 62 x 66	
SP0500-UT	500 Gal Upright Rectangle	250	223		P	1		74 x 40 x 75 273#	31 x 74 x 70	
SP0750-UT	750 Gal Upright Rectangle	250	318		P	1		82 x 40 x 91 368#	82 x 35 x 86	
SP1000-UT	1000 Gal Upright Rectangle	250	407		P	1		92 x 40 x 94 507#	40 x 92 x 89	

PART NO.	RECTANGLE TANKS - TOTAL DRAIN	CLASS	WGT	FSU	SINGLE QNTY	PLT QNTY		MAX PALLET DIMS	PROD DIMS	NOTES
SP0035-RT	35 Gal Rectangle	250	19	FSU	BOX	2 to 8			19 x 28 x 20	
SP0056-RT	56 Gal Rectangle	250	32	FSU	SW	2 to 8			20 x 38 x 26	

PART NO.	LOW-PROFILE RECTANGLE TANKS	CLASS	WGT	FSU	SINGLE QNTY	PLT QNTY		MAX PALLET DIMS	PROD DIMS	NOTES
LP0050-RT	50 Gal Low-Profile Rectangle	150	37	FSU	BOX	2 to 9			24 x 43 x 15	
LP0068-RT	60 Gal Low-Profile Rectangle	250	42	FSU	SW	2 to 9			26 x 42 x 17	
LP0110-RT	110 Gal Low-Profile Rectangle	250	60	FSU	CB	2 to 7			35 x 48 x 19	
LP0200-RT	200 Gal Low-Profile Rectangle	250	84		P	1 to 4			48 x 60 x 19	
LP0300-RT	300 Gal Low-Profile Rectangle	250	135		P	1 to 3			48 x 80 x 21	
LP0300-HT	300 Gal Holding Tank	250	132		CP	2			95 x 56 x 16	

PART NO.	POWDER COATED STEEL BANDS	CLASS	WGT	FSU	SINGLE QNTY			MAX PALLET DIMS	PROD DIMS	NOTES
SP0050-SBP	50 Gallon Rectangle Kit	60	7	FSU	BOX				2 x 545	SHIPPED IN OR ON TANK OR SW IF SHIPPED ALONE
SP0080-SBP	80 Gallon Rectangle Support Band	60	21		SW				3 x 93	
SP0100-SBP	100 Gallon Rectangle Kit	60	11		SW				2.25 x 70.5	
SP0150-SBP	150 Gallon Rectangle Kit	60	14		SW				2.25 x 77.5	
SP0200-SBP	200 Gallon Rectangle Kit	60	16		SW				2.25 x 94	
LP0050-SBP	50 Gallon Low-Profile Band Kit	60	7		SW				2 x 51	SHIPPED IN OR ON TANK OR SW IF SHIPPED ALONE
LP0068-SBP	68 Gallon Low-Profile Band Kit	60	7		SW				2 x 58	
LP0110-SBP	110 Gallon Low-Profile Band Kit	60	11		SW				2 x 69	
LP0200-SBP	200 Gallon Low-Profile Band Kit	60	14		SW				2 x 82.5	
LP0300-SBP	300 Gallon Low-Profile Band Kit	60	16		SW				2 x 86.5	

SPECIALTY TANKS

PART NO.	RINSE TANKS	CLASS	WGT	FSU	SINGLE QNTY	PLT QNTY	BOX QNTY	MAX PALLET DIMS	PROD DIMS	NOTES
SPBM2.5-RT	2.5 Gal Rectangle	150	3.5	FSU	BOX	2 to 8 boxes	12/box		7 x 15 x 14	
SPBM003-RT	3 Gal Rectangle	150	4	FSU	BOX	2 to 8 boxes	12/box		7 x 12 x 14	
SP03.5-CL	3.5 Gal Cylinder	150	5	FSU	BOX	2 to 8 boxes	12/box		11 x 15	
SPBM04-SQ5	4 Gal Square	150	5	FSU	BOX	2 to 8 boxes	10/box		11 x 11 x 15	
SPBM04-SQ7	4 Gal Square	150	5	FSU	BOX	2 to 8 boxes	10/box		11 x 11 x 16	
SPBM04-SQ8	4 Gal Square	150	5	FSU	BOX	2 to 8 boxes	10/box		11 x 11 x 14	
SPBM05-SQ5	5 Gal Square	250	5	FSU	BOX	2 to 8 boxes	8/box		11 x 11 x 20	
SPBM05-SQ7	5 Gal Square	250	5	FSU	BOX	2 to 8 boxes	8/box		11 x 11 x 20	
SPBM05-SQ8	5 Gal Square	250	5	FSU	BOX	2 to 8 boxes	8/box		11 x 11 x 18	
SP0010-SQ8	10 Gal Square	150	10	FSU	BOX	1/2 to 2 boxes	12/box		13 x 13 x 21	
SP0015-SQ5	15 Gal Square	150	16	FSU	BOX	1/2 to 2 boxes	8/box		16 x 16 x23	
SP0015-SQ7	15 Gal Square	150	16	FSU	BOX	1/2 to 2 boxes	8/box		16 x 16 x23	
SP0015-SQ8	15 Gal Square	150	16	FSU	BOX	1/2 to 2 boxes	8/box		16 x 16 x23	

PART NO.	RECTANGLE TANKS - FLAT BOTTOM	CLASS	WGT	FSU	SINGLE QNTY	PLT QNTY	BOX QNTY	MAX PALLET DIMS	PROD DIMS	NOTES
SP002.8-RT	2.8 Gal Rectangle	125	4	FSU	BOX	8	16		9 x 14 x 9	
SP0005-RT	5 Gal Rectangle	150	6	FSU	BOX	2 gaylords	26/gaylord		10 x 22 x 8	
SP0006-2P	6 Gal Rectangle	125	6	FSU	BOX	2 gaylords	24/gaylord		12 x 15 x 8	
SP0006-5N	6 Gal Rectangle	125	6	FSU	BOX	2 gaylords	24/gaylord		12 x 15 x 8	
SP0007-RT	7 Gal Rectangle	125	8	FSU	BOX	1/2 to 2 gaylords	20/gaylord		9 x 14 x 15	
SP0016-MM	16 Gal Rectangle	150	10	FSU	BOX	6 to 24	3/box		14 x 21 x 14	
SP0020-OM	20 Gal Upright Rectangle	150	17	FSU	BOX	6 to 24	-	40 x 48 x 96 450#	11 x 15 x 31	

PART NO.	APPLICATOR TANKS - SUMP ON BOTTOM	CLASS	WGT	FSU	SINGLE QNTY	PLT QNTY		MAX PALLET DIMS	PROD DIMS	NOTES
SP0008-VM	8 Gal Loaf	250	7	FSU	BOX	8 to 30			12 x 16 x 17	
SP0012-RT	12 Gal Rectangle	150	10	FSU	BOX	8 to 24			14 x 18 x 12	
SP0012-VM	12 Gal Loaf	150	10	FSU	BOX	8 to 24			12 x 16 x 22	
SP0019-VM	19 Gal Loaf	150	15	FSU	BOX	8 to 24			12 x 16 x 28	
SP0020-LC	20 Gal Rectangle	150	12	FSU	BOX	8 to 24			14 x 28 x 12	

PART NO.	SPOT SPRAYERS	CLASS	WGT	FSU	SINGLE QNTY	PLT QNTY		MAX PALLET DIMS	PROD DIMS	NOTES
SM0014-14S	14 Gallon with sump	250	8	FSU	BOX	6 to 20			14 x 30 x 14	
SS0014-14	14 Gallon No sump	250	8	FSU	BOX	6 to 20			14 x 30 x 14	
SM0025-18S	25 Gallon with sump	250	14	FSU	BOX	4 to 10			18 x 34 x 18	
SS0025-18	25 Gallon No sump	250	14	FSU	BOX	4 to 10			18 x 34 x 18	

-S = sump

PART NO.	BLOW-MOLDED APPLICATOR TANKS	CLASS	WGT	FSU	SINGLE QNTY	PLT QNTY		MAX PALLET DIMS	PROD DIMS	NOTES
SB00040SWSS	40 Gallon White single tank	300	18	FSU	BOX				24 x 36 x 19	
SB40WP-DR	40 Gallon White pallet quantity		193			2 to 10		36 x 48 x 96		
SB00040SYSS	40 Gallon Yellow single tank	300	18	FSU	BOX				24 x 36 x 19	
SB40YP-DR	40 Gallon Yellow pallet quantity		193			2 to 10		36 x 48 x 96		
SB00060SWSS	60 Gallon White single tank	300	21	FSU	BOX				24 x 36 x 26	
SB60WP-DR	60 Gallon White pallet quantity		188			2 to 8		36 x 48 x 96		
SB00060SWSS	60 Gallon Yellow single tank	300	21	FSU	BOX				24 x 36 x 26	
SB60WP-DR	60 Gallon Yellow pallet quantity		188			2 to 8		36 x 48 x 96		

PART NO.	PCO TANKS	CLASS	WGT	FSU	SINGLE QNTY	PLT QNTY		MAX PALLET DIMS	PROD DIMS	NOTES
PCO035-16W	35 Gallon	250	26	FSU	BOX	2 to 10			16 x 35 x 21	
PCO050-19S	50 Gallon w/ sump	250	27	FSU	SW	2 to 10			19 x 38 x 23	
PCO050-19W	50 Gallon	250	27	FSU	BOX	2 to 10			19 x 38 x 23	
PCO100-30S	100 Gallon w/ sump	250	52	FSU	SW	2 to 5			30 x 38 x 29	
PCO100-30W	100 Gallon	250	52	FSU	SW	2 to 5			30 x 38 x 29	
PCO150-37S	150 Gallon w/ sump	250	63		P	1 to 4			37 x 48 x 29	
PCO150-37W	150 Gallon	250	63		P	1 to 4			37 x 48 x 29	
PCO200-37S	200 Gallon w/ sump	250	84		P	1 to 2			37 x 48 x 38	
PCO200-37W	200 Gallon	250	84		P	1 to 2			37 x 48 x 38	
PCO300-37S	300 Gallon w/ sump	250	160		P	1 to 2			37 x 69 x 40	
PCO300-37W	300 Gallon	250	160		P	1 to 2			37 x 69 x 40	

S = Sump / W = Without Sump

PART NO.	POWDER COATED STEEL BANDS FOR PCO'S	CLASS	WGT	FSU	SINGLE QNTY			MAX PALLET DIMS	PROD DIMS	NOTES
PC0035-SB*	35 Gallon Set Silver	60	3	FSU	SW				2 x 50.5	
PC0050-SBP	50 Gallon Set Black	60	6	FSU	SW				2.5 x 57.5	
PC0100-SBP	100 Gallon Set Black	60	20	FSU	SW				2.5 x 76	SHIPPED IN OR ON TANK OR SW IF SHIPPED ALONE
PC0150-SBP	150 Gallon Set Black	60	30	FSU	SW				3.5 x 82	
PC0200-SBP	200 Gallon Set Black	60	36	FSU	SW				3.5 x 98	
PC0300-SBP	300 Gallon Set Black	60	40	FSU	SW				4 x 100	

* PC0035-SB is stainless steel

PART NO.	SEPTIC TANKS	CLASS	WGT	FSU	SINGLE QNTY	PLT QNTY		MAX PALLET DIMS	PROD DIMS	NOTES
AST-0300-1	300 Gallon Pump Tank	300	137		P	1			54 x 56	
AST-0300-1R	300 Gallon Pump Tank	300	137		P	1				
AST-0500-1	500 Gallon Pump Tank	300	197		P	1			63 x 74	
AST-0500-1R	500 Gallon Pump Tank	300	197		P	1				
AST-0750-1	750 Gallon Single Compartment	300	259		P	1			60 x 70 x 60	
AST-0750-1R	750 Gallon Single Compartment	300	259		P	1				

PART NO.	SEPTIC TANKS continued	CLASS	WGT	FSU	SINGLE QNTY	PLT QNTY		MAX PALLET DIMS	PROD DIMS	NOTES
AST-1000-1	1000 Gallon Single Compartment	300	396		P	1			60 x 101 x 60	
AST-1000-2	1000 Gallon Two Compartments	250	448		P	1			60 x 101 x 60	
AST-1250-1	1250 Gallon Single Compartment	300	446		CP	1			58 x 118 x 72	
AST-1250-2	1250 Gallon Two Compartments	300	492		CP	1			58 x 118 x 72	
AST-1500-1	1500 Gallon Single Compartment	300	534		CP	1			58 x 137 x 72	
AST-1500-2	1500 Gallon Two Compartments	300	580		CP	1			58 x 137 x 72	

PART NO.	LOW PROFILE SEPTIC TANKS	CLASS	WGT	FSU	SINGLE QNTY	PLT QNTY		MAX PALLET DIMS	PROD DIMS	NOTES
LPS-1000-1	1000 Gallon Low Profile		513						72 x 121 x 58	Flat / Step
LPS-1000-2	1000 Gallon Low Profile 2 Compartment		533						72 x 121 x 58	Flat / Step
LPS-1250-1	1250 Gallon Low Profile		588						72 x 137 x 58	Flat / Step
LPS-1250-2	1250 Gallon Low Profile 2 Compartment		608						72 x 137 x 58	Flat / Step
LPS-1500-1	1500 Gallon Low Profile		694						72 x 153 x 58	Flat / Step
LPS-1500-2	1500 Gallon Low Profile 2 Compartment		714						72 x 153 x 58	Flat / Step

PART NO.	LOW PROFILE SEPTIC TANKS	CLASS	WGT	FSU	SINGLE QNTY	PLT QNTY		MAX PALLET DIMS	PROD DIMS	NOTES
LPS-14684	36" dia Riser & Lid		69		SW				34 x 45	
ACT-16052BK	28" Aquifer Ground Access Assy-Riser & Lid		53		SW				34 x 38	
ACT-16053BK	24" Aquifer Burial Lid & Gasket BLK		17		SW				35 x 8	
LSP18000-xx	Internal Plumbing Kit				SW					
	xx = State Specific									

PART NO.	CISTERN TANKS	CLASS	WGT	FSU	SINGLE QNTY	PLT QNTY		MAX PALLET DIMS	PROD DIMS	NOTES
AST-0325-1W	325 Gallon	300	134		P	1			54 x 56	
AST-0525-1W	525 Gallon	300	194		P	1			63 x 74	
AST-0850-1W	850 Gallon	300	259		P	1			60 x 70 x 60	
AST-1150-1W	1150 Gallon	300	414		P	1			60 x 101 x 60	
AST-1450-1W	1450 Gallon	300	473		CP	1			58 x 118 x 72	
AST-1700-1W	1700 Gallon	300	567		CP	1			58 x 137 x 72	

PART NO.	SEPTIC/CISTERN TANK ACCESSORIES	CLASS	WGT	FSU	SINGLE QNTY			MAX PALLET DIMS	PROD DIMS	NOTES
AST19365	7" Access Extension -Black	300	13	FSU	SW				32.5 x 13.5	
AST19379	7" Access Extension -White	300	13	FSU	SW				32.5 x 13.5	
AST19212	16" Access Extension -Black	250	35	FSU	SW				32.5 x 22	
AST19214	16" Access Extension -White	250	35	FSU	SW				32.5 x 22	
AST19368	16" Access Extension -Green	250	35	FSU	SW				32.5 x 22	
AST19211	24" Ace Access Cover - Black	250	17	FSU	SW				32.5 x 8	
AST19213	24" Ace Access Cover - White	250	14	FSU	SW				32.5 x 8	
AST19366	24" Ace Access Cover - Green	250	17	FSU	SW				32.5 x 8	
ACT-19486	24" Ace Access Cover - Blue	250	14	FSU	SW				32.5 x 8	
AST19257	8" dia. Riser & Lid - Black	300	20	FSU	SW				32.5 x 29	
AST19258	8" dia. Riser & Lid - White	300	20	FSU	SW				32.5 x 29	
AST19544	24" Septic/Cistern Opening Restrictor	125	4	FSU	BOX				22 x 2	
AST19553	24" Aquifer Opening Restrictor	125	7	FSU	BOX				23 x 23 x 2	
AST10078	4" Sanitary Gasket		1	FSU	BOX				4.00 ID x 8 OD	
AST10084	4" Sch. 40 Gasket		1	FSU	BOX				4.25 ID x 8 OD	
AST19256	4" Gasket Retainer & Hardware		1	FSU						
AST10154	Divider Panel Assembly - for 1000 gal w/Hardware		52							
AST19233	Divider Panel Assembly - for 1250/1500 gal w/Hardware		46							
AST18000-xx	Internal Plumbing Kit									

xx = State Specific

PART NO.	AQUIFER LOW-PROFILE CISTERN TANKS	CLASS	WGT	FSU	SINGLE QNTY	PLT QNTY		MAX PALLET DIMS	PROD DIMS	NOTES
ACT1000-LPB	1000 Gallon w/ Burial Lid	250	559				*		98 x 111 x 36	Flat / Step
ACT1000-LPG	1000 Gallon w/ Ground Access Assembly	250	595				+		98 x 111 x 36	Flat / Step
ACT1500-LPB	1500 Gallon w/ Burial Lid	250	702				*		98 x 111 x 48	Flat / Step
ACT1500-LPG	1500 Gallon w/ Ground Access Assembly	250	738				+		98 x 111 x 48	Flat / Step
ACT2000-LPB	2000 Gallon w/ Burial Lid	250	917				*		98 x 158 x 45	Flat / Step
ACT2000-LPG	2000 Gallon w/ Ground Access Assembly	250	953				+		98 x 158 x 45	Flat / Step
ACT2500-LPB	2500 Gallon w/ Burial Lid	250	1031				*		98 x 158 x 54	Flat / Step
ACT2500-LPG	2500 Gallon w/ Ground Access Assembly	250	1067				+		98 x 158 x 54	Flat / Step
ACT-16054	16" Aquifer Grnd Access Assy-Riser & Lid	250	43	FSU	P / SW				34 x 24	
ACT-16052	28" Aquifer Grnd Access Assy-Riser & Lid	250	53	S	P / SW				34 x 38	
ACT-16053	24" Aquifer Burial Lid & Gasket	250	17	FSU	SW				35 x 8	

PART NO.	LIQUID FEEDER TANKS & WHEELS	CLASS	WGT	FSU	SINGLE QNTY	PLT QNTY		MAX PALLET DIMS	PROD DIMS	NOTES
LTA155-55	155 Gallon 6 BOLTS FOR LID	300	57		P	1 to 10			50 x 38	
LTA180-68	180 Gallon 8 BOLTS FOR LID	400	75		P	1 to 10			68 x 34	
LTA285-68	285 Gallon 8 BOLTS FOR LID	400	98		P	1 to 10			68 x 39	
LT17W	17 Inch Wheel	-	2	FSU						
LTA180-68	Up to 4 Wheels 4 Bolts per wheel 5/16" x 1"									
LT24W	24 Inch Wheel	-	4	FSU						
LTA155-55	Up to 3 Wheels 2 washers per bolt									
LTA285-68	Up to 4 Wheels 1 nut per bolt									

PART NO.	MISCELLANEOUS	CLASS	WGT	FSU	SINGLE QNTY	PLT QNTY		MAX PALLET DIMS	PROD DIMS	NOTES
MF-10198	100 lb Mineral Feeder	-	91		P	1 to 4	*		72 x 72 x 54	*MINERAL FEEDER
SJ-10183	3.5 Bushel Feed Cart - Standard	125	60	FSU	SW				18 x 40 x 36	WRAPPED AS 2
SJ10232	3.5 Bushel Feed Cart - Deluxe	125	65	FSU	SW				18 x 40 x 36	PIECES ON PALLET

PART NO.	UTILITY CART	CLASS	WGT	FSU	SINGLE QNTY	PLT QNTY		MAX PALLET DIMS	PROD DIMS	NOTES
UC007.5-27	7.5 Cubic Feet Utility Cart	250	54		P	1		28 x 50 x 25	54 x 28 x 34	

PART NO.	PALLET PAKS	CLASS	WGT	FSU	SINGLE QNTY	PLT QNTY		MAX PALLET DIMS	PROD DIMS	NOTES
SP0150-PP	150 1 Tank, Plastic	250	82		SW				26 x 43 x 47	
	1 Pallet, Plastic	125	20		SW					
	1 Frame, Steel	150	101		SW					
SP0150-2TPP	150 2 Tank, Plastic	250	164		SW				50 x 43 x 47	
	1 Pallet, Plastic	100	40		SW					
	1 Frame, Steel	150	156		SW					
SP0300-PP	300 1 Tank, Plastic	250	122		SW				50 x 43 x 47	
	1 Pallet, Plastic	100	40		SW					
	1 Frame, Steel	150	156		SW					
VT0110-PP	110 Gal Pallet & Tank	250	70		CB				33 x 40 x 44	
VT0210-PP	210 Gal Pallet & Tank	300	84		CB				41 x 52	

PART NO.	PALLET TANKS	CLASS	WGT	FSU	SINGLE QNTY	PLT QNTY		MAX PALLET DIMS	PROD DIMS	NOTES
SP0150-PPTK	150 Gal Rectangle	250	82		P	1 to 4			24 x 40 x 42	
SP0300-PPTK	300 Gal Rectangle	250	122		P	1 to 2			48 x 40 x 42	
VT0110-32	110 Gal Tank Only	300	42		CB				32 x 41	
VT0210-40	210 Gal Tank Only	300	58		CB				40 x 49	

PART NO.	STACKABLE TOTE	CLASS	WGT	FSU	SINGLE QNTY	PLT QNTY		MAX PALLET DIMS	PROD DIMS	NOTES
ST0035-32	35 Gallon Stackable	250	30	FSU	SW	2 to 7		36 x 40 x 89 250#	32 x 32 x 15	
ST0070-32	70 Gallon Stackable	250	42	FSU	P	1 to 5		48 x 40 x 94 250#	32 x 32 x 25	
ST0120-32	120 Gallon Stackable	250	77	FSU	P	1 to 2		40 x 36 x 78 194#	32 x 32 x 38	
ST0180-42	180 Gallon Stackable	250	126		P	1 to 2		42 x 42 x 73 292#	42 x 42 x 35	
ST0240-42	240 Gallon Stackable	250	164		P	1 to 2		42 x 42 x 93 368#	42 x 42 x 45	

PART NO.	STACKABLE TOTE ACCESSORIES	CLASS	WGT	FSU	SINGLE QNTY			MAX PALLET DIMS	PROD DIMS	NOTES
ST70/120-SK	35, 70 or 120 Gallon Tote Skid	150	50	FSU	SW				30 x 30 x 8	
ST024-LG	24" Leg Kit fo Leg Kit for Tote Skid	150	24	FSU	BOX				5 x 5 x 26	
ST036-LG	36" Leg Kit for 35, 70 or 120 Gallon Tote Skid	150	70	FSU	BOX				8 x 8 x 41	
19508	42" Tote Adaptor	150	55	FSU	SW				42 x 42 x 10	
ST180/240-ST	180 or 240 Gallton Tote Stand	150	175		SW				44 x 44 x 27	
ST70/120-DT	35, 70 or 120 Gallon Drip Tray Kit	125	15		BOX				5 x 20 x 35	
ST180/240-DT	180 or 240 Gallon Drip Tray Kit	125	17	FSU	BOX				5 x 20 x 46	
ST70/120-PL-1	35, 70 or 120 Gallon Plumbing Kit for single tank	125	1	FSU	BOX				6 x 6 x 6	
ST70/120-PL-2	35, 70 or 120 Gallon Plumbing Kit for two tanks	100	10	FSU	BOX				16 x 10.5 x 9	
ST70/120-PL-3	35, 70 or 120 Gallon Plumbing Kit for three tanks	92.5	12	FSU	BOX				16 x 10.5 x 9	

PART NO.	BULKHEADS & SYPHON TUBES	CLASS	WGT	FSU	SINGLE QNTY				HOLE REQUIREMENT	NOTES
10897	1/4" Brass Bulkhead	-		FSU	BOX				25/32"	
10058	1/2" Ace Bulkhead	-		FSU	BOX				1 1/4"	
10025	1/2" Polypropylene Bulkhead	-		FSU	BOX				1 3/8"	
13208	3/4" Ace Bulkhead	-		FSU	BOX				1 7/16"	
10484	3/4" Ace Heavy Duty Bulkhead	-		FSU	BOX				1 3/4"	
10485	1" Ace Bulkhead	-		FSU	BOX				1 3/4"	
10503	1" Polypropylene Bulkhead	-		FSU	BOX				2 1/4"	
10918	1 1/4" Ace Bulkhead	-		FSU	BOX				2 1/4"	
10507	1 1/2" Ace Bulkhead	-		FSU	BOX				3"	
10508	2" Ace Bulkhead	-		FSU	BOX				3"	
10486	2" SS Bulkhead Dbl Threaded	-		FSU	BOX				3"	
10912	2" Heavy Duty Fitting - for tanks over 3000 gal	-		FSU	BOX				3 1/4"	
10490	2" SS Bulkhead Hvy - for tanks over 3000 gal	-		FSU	BOX				3 1/4"	
10203*	2" SS Bolt-in Bulkhead	-		FSU	BOX				2 1/4"	* \$15 ADDITIONAL INSTALLATION FEE APPLIES TO THIS FITTING
10528	3" Ace Bulkhead	-		FSU	BOX				4 1/2"	
10915*	3" Bolt-in Flanged Bulkhead	-		FSU	BOX				3 1/4"	
10487	3" SS Bulkhead Dbl Threaded	-		FSU	BOX				4 1/2"	
10011*	3" SS Bolt-in Bulkhead	-		FSU	BOX				3 3/4"	
11099*	4" SS Bolt-in Bulkhead	-		FSU	BOX				4 7/8"	
10513	4" Bulkhead Fitting	-		FSU	BOX				5 3/4"	
10511	2" Syphon Tube	-		FSU	BOX					
10488	2" Long Syphon Tube	-		FSU	BOX					
10489	3" Long Syphon Tube	-		FSU	BOX					
12438	4" Long Syphon Tube	-		FSU	BOX					

PART NO.	LIDS	CLASS	WGT	FSU	SINGLE QNTY				PROD DIMS	NOTES
10631	2" Spin on Kelch Cap	-		FSU	BOX					
13108	3-1/2" Lid & Lanyard Assembly	-		FSU	BOX					
10529	4" Center Lid With Air Breather	-		FSU	BOX					
13696	5" Spin-on Lid with Spring Vent	-		FSU	BOX					
13748	5" Threaded Non-Vented Lid	-		FSU	BOX					
13709	5" Spin-on Lid with Step Vent	-		FSU	BOX					
19406	5" Hinged Low-Profile	-		FSU	BOX					
12415	7" Spin-on Non-Vented Lid	-		FSU	BOX					
12414	7" Spin-on Spring-Vented Lid	-		FSU	BOX					
12427	7" Spin-on Lid w/ Step Vent	-		FSU	BOX					
10525	8" Threaded Vented Lid & Ring	-		FSU	BOX					
10520	- Breather Only - for 8" & 12" Lids	-		FSU	BOX					
10526	12" Threaded Non-Vented Lid & Ring	-		FSU	BOX					
10527	12" Threaded Vented Lid & Ring	-		FSU	BOX					

PART NO.	LIDS cont.	CLASS	WGT	FSU	SINGLE QNTY				PROD DIMS	NOTES
10528	16" Threaded Vented Lid & Ring			FSU	BOX					
15082	16" Hinged Lid Vented			FSU	BOX					
15083	16" Hinged Lid Non-Vented			FSU	BOX					
10530	22" Threaded Vented Lid & Ring			FSU	BOX					
10873	12" Short Black Lanyard (for 5", 8" & 12" lids)			FSU	BOX					
12460	12" Self-Anchoring Lanyard (for 5" & 7" lids)			FSU	BOX					
10534	16" Long Black Lanyard (for 12" & 16" lids)			FSU	BOX					
19024	3/4" Outlet Gap			FSU	BOX					
19025	Tether for Outlet Gap			FSU	BOX					
10960	Gasket for Outlet Gap	-		FSU	BOX					

PART NO.	GASKETS	CLASS	WGT	FSU	SINGLE QNTY				PROD DIMS	NOTES
12000	1 3/8" Viton Gasket	-		FSU	BOX				1 3/8"	
12010	1 5/8" Viton Gasket	-		FSU	BOX				1 3/4" or 1 5/8"	
12002	2 1/4" Viton Gasket	-		FSU	BOX				2 1/4"	
12003	3" Viton Gasket	-		FSU	BOX				3"	
12004	3 1/4" Viton Gasket	-		FSU	BOX				3 1/4"	
12005	4 1/2" Viton Gasket	-		FSU	BOX				4 1/2"	

PART NO.	J-BOLTS	CLASS	WGT	FSU	SINGLE QNTY				PROD DIMS	NOTES
J.313 x 3.000	5/16" w/ 3" length	-		FSU	BOX					
J.375 x 3.750	3/8" w/ 3-3/4" length	-		FSU	BOX					
J.375 x 5.000	3/8" w/ 5" length	-		FSU	BOX					
J.500 x 6.000-4	1/2" w/ 6" length			FSU	BOX					
J.625 x 7.000	5/8" w/ 7" length			FSU	BOX					
J.625 x 8.000	5/8" w/ 8" length			FSU	BOX					
J.625 x 8.000-SS	5/8" w/ 8" length (Stainless Steel)			FSU	BOX					

P = WOOD PALLETS DIMENSIONS 40" x 48" x 5" CLASS 70
CP = CUSTOM PALLET \$25.00 CHARGE DIMENSIONS VARY BY PRODUCT CLASS 70
CP/PVC = CUSTOM PALLET FOR AQUIFER CISTERN TANKS \$69.00
OP0100-RT CP = CUSTOM PALLET CHARGE \$14
OP0150-RT CP = CUSTOM PALLET CHARGE \$18
OP0210-RT CP = CUSTOM PALLET CHARGE \$22
OP0425-RT CP = CUSTOM PALLET CHARGE \$27
BR = CROSS BRACES \$15.00 DEPOSIT REFUNDABLE IF RETURNED
SB = SHIPPING BLOCKS \$40.00 DEPOSIT REFUNDABLE IF RETURNED
SW = SHRINK WRAP
CB= CARD BOARD \$0.02/ GALLON
TS1 = TRANSPORT SECTIONS \$40.00 REFUNDABLE IF RETURNED 35 lbs
TS2 = TRANSPORT SECTIONS \$40.00 REFUNDABLE IF RETURNED 48 lbs

NATIONAL MOTOR FREIGHT CLASSIFICATION

THE ABOVE INFORMATION WAS COMPILED USING THE NATIONAL MOTOR FREIGHT CLASSIFICATION GUIDELINES. FREIGHT CARRIERS OCCASIONALLY USE DIFFERENT CLASSIFICATIONS. CONTACT YOUR SELECTED CARRIER FOR A CONFIRMED CLASSIFICATION.

TANKS (PLASTIC ARTICLES - BASED ON DENSITY)

ITEM 156600, SUB 1, CLASS 400
 ITEM 156600, SUB 2, CLASS 300
 ITEM 156600, SUB 3 CLASS 250
 ITEM 156600, SUB 4, CLASS 150
 ITEM 156600, SUB 5, CLASS 125
 ITEM 156600, SUB 6, CLASS 100
 ITEM 156600, SUB 7, CLASS 92.5
 ITEM 156600, SUB 8, CLASS 85
 ITEM 156600, SUB 9, CLASS 70

STANDS

ITEM 178680, SUB 1, CLASS 150
 ABF: ITEM 178690, SUB ____, CLASS ____ (BASED ON DENSITY)

HOOPS

ITEM 52460, SUPPORTS (ARCHES), CLASS 60

FEED CART

ITEM 188925, SUB 6, CLASS 125

TANK LADDER

ITEM 108740, SUB 00, CLASS 70
 PLUMBING KID (DENSITY ITEM)
 ITEM 95190, SUB 6, CLASS 100
 ITEM 95190, SUB 7, CLASS 92.5