

PROPRIETARY DATA

PROPERTY OF ACE ROTO-MOLD MFG., INC. INFORMATION FURNISHED HEREIN IS THE PROPERTY OF ACE ROTO-MOLD MFG., INC. AND SHALL NOT BE USED, DISCLOSED TO OTHERS, OR COPIED WITHOUT THE EXPRESSED WRITTEN CONSENT OF ACE ROTO-MOLD MFG., INC. ALL RIGHTS RESERVED.

PART NUMBER	DESCRIPTION	MATERIAL
12093	PLUG, 3/8" HEX DRIVE GREEN	66328
12086	PLUG, 3/8" HEX DRIVE BLUE	66326
12137	PLUG, 3/8" HEX DRIVE ORANGE	66444
12141	PLUG, 3/8" HEX DRIVE YELLOW	66445
10157	PLUG, 3/8" HEX DRIVE WHITE	60402W
10237	PLUG, 3/8" HEX DRIVE BLACK	62202

10237

C

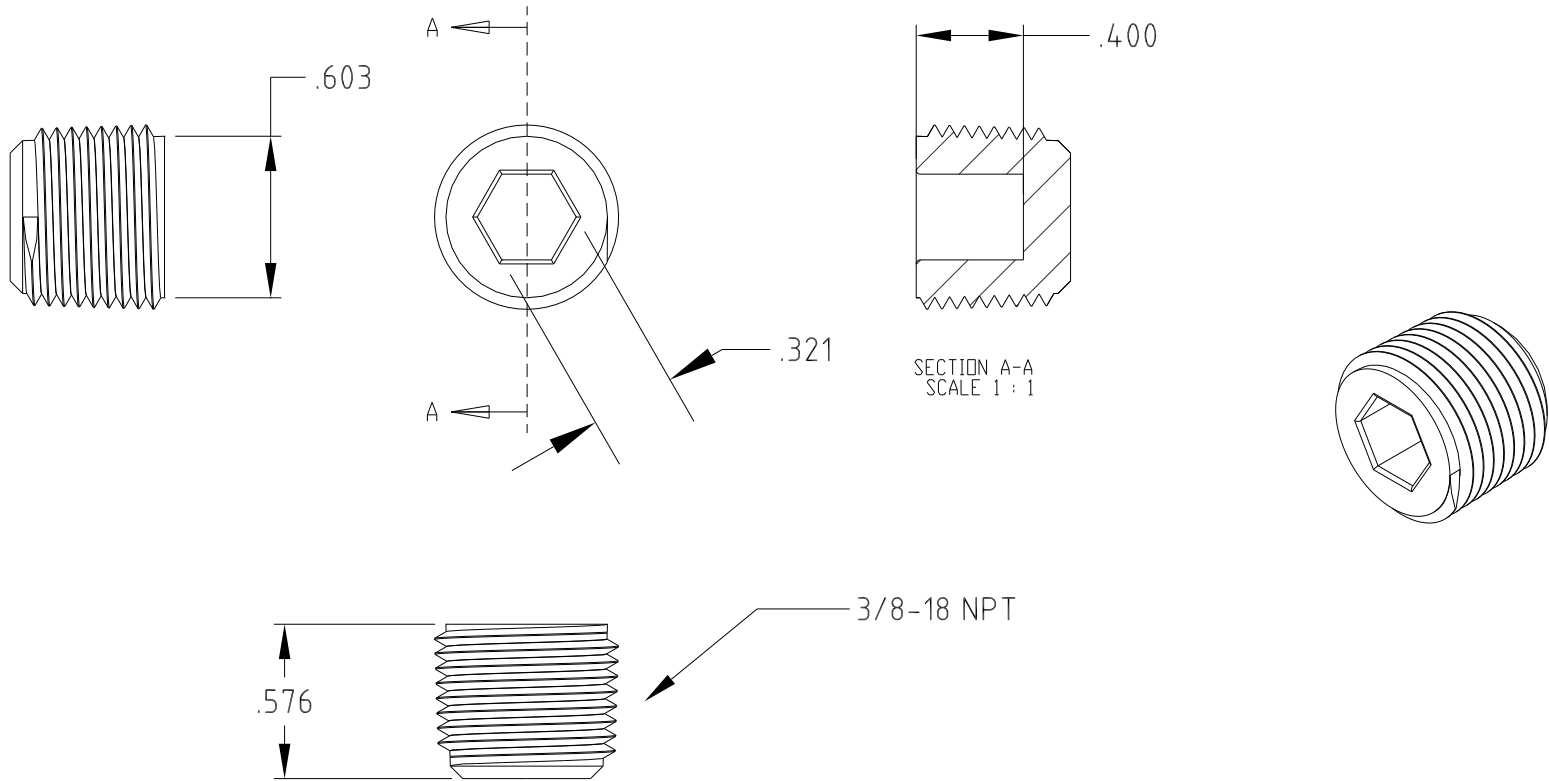

NOTE:
UV INHIBITOR REQUIRED

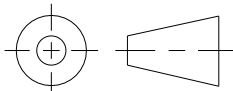
C	ADDED P.N. TABLE	CCN 1509	11/16/07	ADH	DRAWN / DATE	MATERIAL	 INJECTION MOLDING A DIVISION OF DEN HARTOG INDUSTRIES, INC. 4010 HOSPERS DRIVE S., BOX 425, HOSPERS, IOWA 51238-0425		
B	UPDATE LOGO	CCN 1296	4/17/07	GWC	GWC / 5-11-06	NO BREAK POLYPROPYLENE REFERENCE MATERIAL DATA SHEET FOR SPECIFIC PROPERTIES.			
A	ADD NOTE ON UV ADDITIVE		3/8/07	GWC	APPRD. / DATE				
REV	DESCRIPTION		DATE	APPRD	REH 4/18/07		CLIENT / DESCRIPTION		
ALL DIMENSIONS ARE IN DECIMAL INCHES TOLERANCES UNLESS OTHERWISE SPECIFIED .XXX +/- .006 .XX +/- .016 .X +/- .032						THIRD ANGLE PROJECTION ANSI 14.5M 	NOTES: 1. PART WEIGHT 3 GRAMS	3/8" NPT Plug	
						SCALE	N.S.	PART NO.	SEE SCH.