

© DEN HARTOG INDUSTRIES, INC.

Copyright. All information furnished within this document, electronic file or design correspondence is the property of Den Hartog industries, Inc. and shall not be used, disclosed to others or copied without the expressed written consent of Den Hartog Industries, Inc.

KEY	PART NUMBER	DESCRIPTION	QTY.
1	12449-SSNB	ANCHOR RITE, 22 NUT	1
2	12602	BOLT, 3/8"-16 X 4" HEX SS	1
3	11094	WASHER, 3/8" X 1" OD FLAT SS	1

12449-SS

F

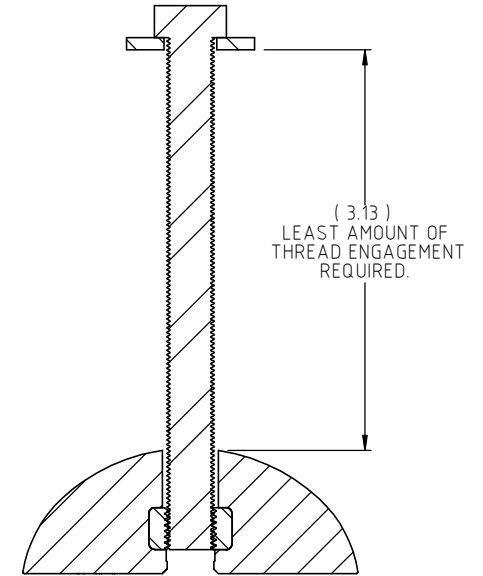
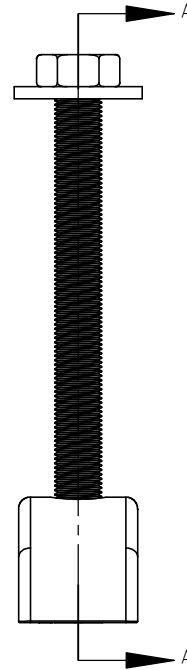
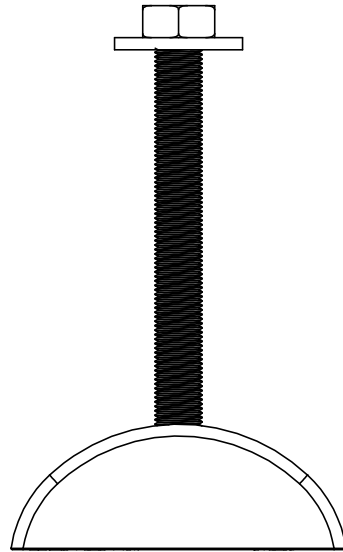
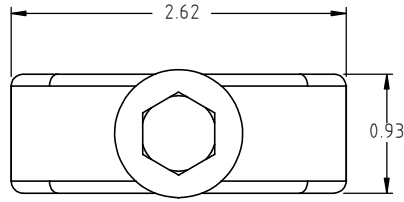
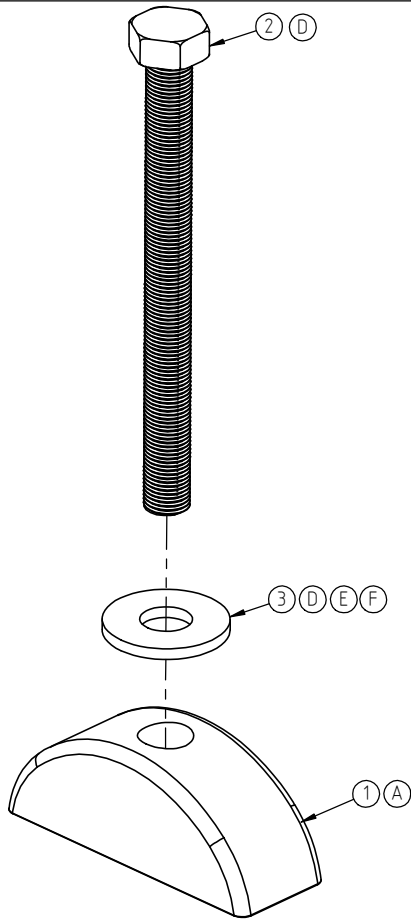

SECTION A-A
SCALE 1:15

F	SJ10102 CHANGED BACK TO 11094.	ADH 1/9/15	2999
E	SJ10102 WAS 11094, PRINT LAYOUT/TEMPLATE UPDATED.	ADH 9/15/14	2914
D	BOLT AND WASHER GIVEN SEPARATE P.N.'S	ADH 11/17/08	
C	YELLOW COLORANT REMOVED	ADH 1/18/08	1563
B	COLOR WAS BLACK	REH 7/27/07	1405
A	ADD PART NUMBER	GWC 6/7/07	1405
REV	DESCRIPTION	BY / DATE	CCN

DRAWN / DATE	MATERIAL
GWC 2/5/07	(A)(C)(E)
APPRD. / DATE	SEE COMPONENTS
REH 4/6/07	

SHOT WEIGHT:	NOTES:
SHIPPING WEIGHT:	(B)
21.50 LBS PER 100 PC.	
FINISH:	



Den Hartog
INDUSTRIES, INC.

Ace Roto-Mold Injection Molding Blow Molding Sowjoy

4010 HOSPERS DRIVE S. BOX 425, HOSPERS, IOWA 51238-0425

DESCRIPTION	ANCHOR RITE-STAINLESS STEEL NUT	
SCALE	N.S.	PART NO. 12449-SS

ALL DIMENSIONS ARE IN DECIMAL INCHES
TOLERANCES UNLESS OTHERWISE SPECIFIED

THIRD ANGLE PROJECTION
ANSI 14.5M

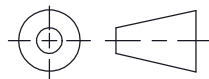

NOTE
TOLERANCE:
.XXX ± .005"
.XX ± .010
ANGLE ± 1°