

Copyright. All information furnished within this document, electronic file or design correspondence is the property of Den Hartog industries, Inc. and shall not be used, disclosed to others or copied without the expressed written consent of Den Hartog Industries, Inc.

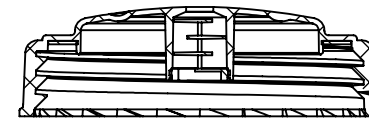
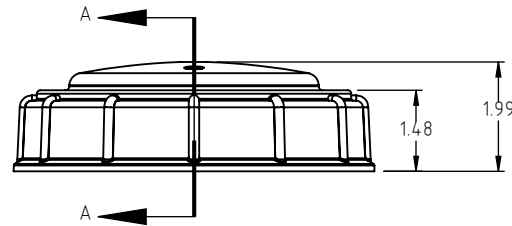
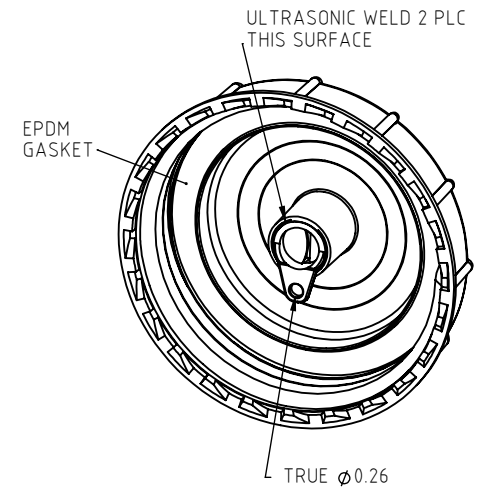
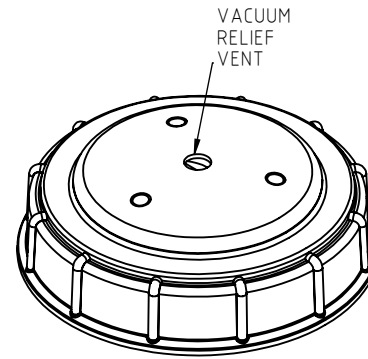
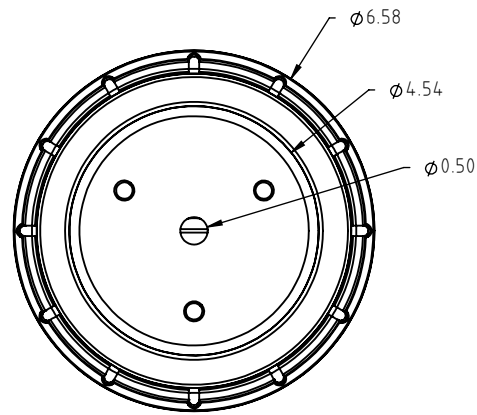
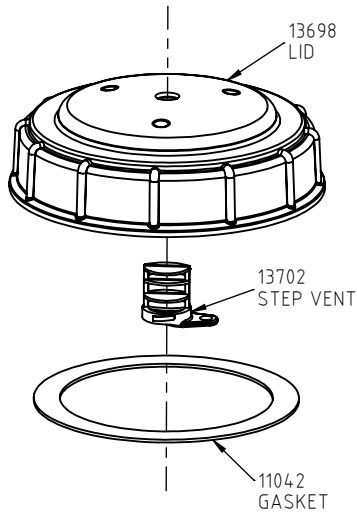

SECTION A-A
SCALE 1: 3.5

AMERICAN NATIONAL
STANDARD BUTTRESS
6 INCH DIA. X 3TPI

				DRAWN / DATE ADH 7/19/12	MATERIAL
				APPROD. / DATE MVE 9/18/12	
REV	DESCRIPTION	BY / DATE	CCN	SHOT WEIGHT:	NOTES:
				SHIPPING WEIGHT: 140 g.	
				FINISH:	
ALL DIMENSIONS ARE IN DECIMAL INCHES TOLERANCES UNLESS OTHERWISE SPECIFIED		THIRD ANGLE PROJECTION ANSI 14.5M			
NOTE	TOLERANCE:				



Den Hartog
INDUSTRIES, INC.

Ace Roto-Mold Injection Molding Blow Molding Sowjoy

4010 HOSPERS DRIVE S. BOX 425, HOSPERS, IOWA 51238-0425

DESCRIPTION 5" LID WITH 2 WAY STEP VENT AND GASKET	
SCALE N.S.	PART NO. 13714