

© DEN HARTOG INDUSTRIES, INC.

Copyright. All information furnished within this document, electronic file or design correspondence is the property of Den Hartog Industries, Inc. and shall not be used, disclosed to others or copied without the expressed written consent of Den Hartog Industries, Inc.

14762

B

KEY	PART NUMBER	DESCRIPTION	QTY.
1	14750	RING	1
2	14752	LID	1
3	14754	ARM	1
4	14751	VENT BASE, NON-VENTED	1
5	14755	PIN	1
6	15067	GASKET, 16" TECOMECS LID	1
7	14764	O-RING, 4mm WIDE X 146mm ID	1
8	12880	GASKET, 16" TANK LID	1

ⓑ

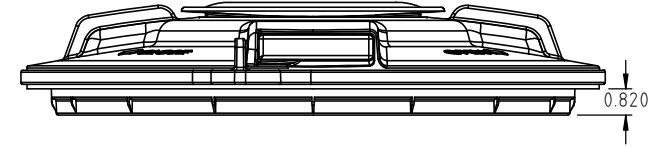
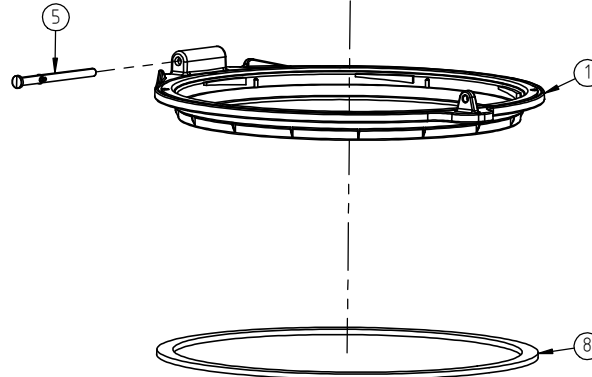
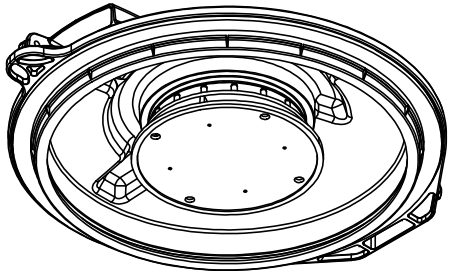
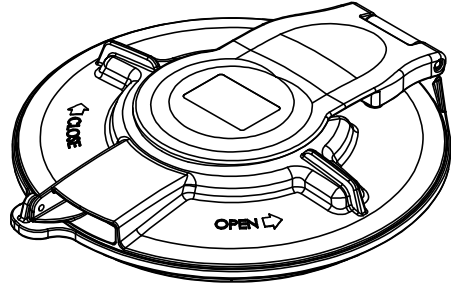

APPLY 90369 LUBRICANT TO 14053 AND 14764 O-RINGS ⓐ BEFORE ASSEMBLY.

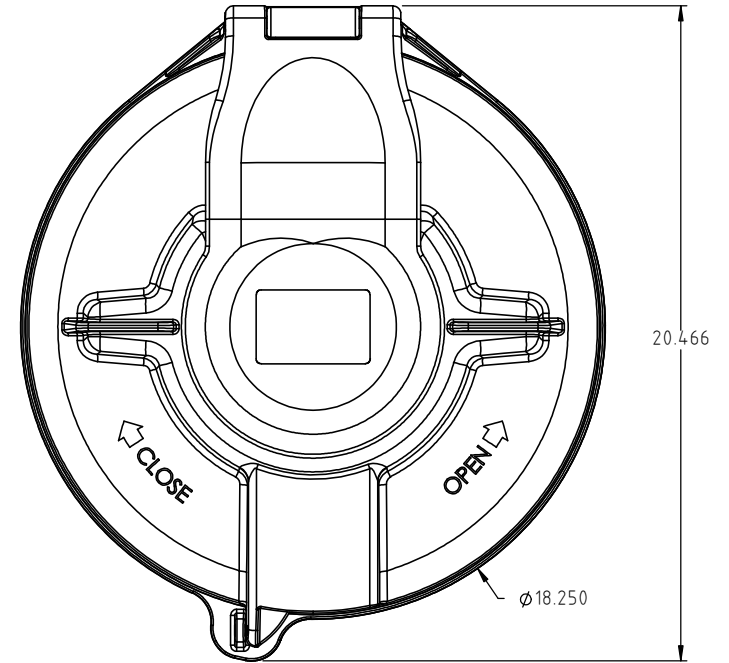

REV	DESCRIPTION	BY / DATE	CCN	DRAWN / DATE	MATERIAL
B	15067 WAS 14053	ADH 3/12/20	3931	ADH 10/25/17	SEE COMPONENTS
A	90369 LUBRICANT NOTE ADDED	ADH 6/11/19	3785	APPRD. / DATE REH 12/4/17	
REV	DESCRIPTION	BY / DATE	CCN		

ALL DIMENSIONS ARE IN DECIMAL INCHES TOLERANCES UNLESS OTHERWISE SPECIFIED		THIRD ANGLE PROJECTION ANSI 14.5M	SHOT WEIGHT: N.A.	NOTES:
NOTE	TOLERANCE: .XXX ± .005" .XX ± .010 ANGLE ± 1°		SHIPPING WEIGHT: 5.2 LBS.	
			FINISH:	



**Den Hartog**  
INDUSTRIES, INC.

Acra Roto-Mold Injection Molding Blow Molding Sowjoy

4010 HOSPERS DRIVE S. BOX 425, HOSPERS, IOWA 51238-0425

DESCRIPTION	16" HINGED LID ASSEMBLY, NON-VENTED	
SCALE	N.S.	PART NO. 14762