

Copyright. All information furnished within this document, electronic file or design correspondence is the property of Den Hartog Industries, Inc. and shall not be used, disclosed to others or copied without the expressed written consent of Den Hartog Industries, Inc.

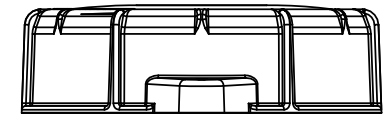

FILLER NECK SPECIFICATIONS $\pm 1\%$ (A) (C)

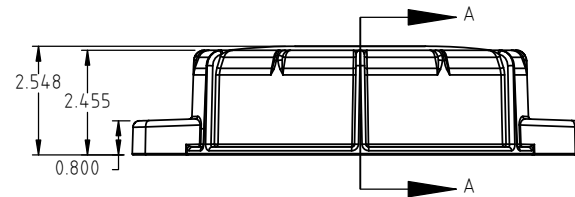
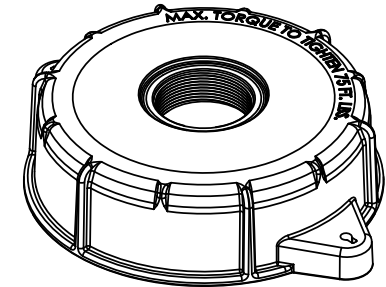
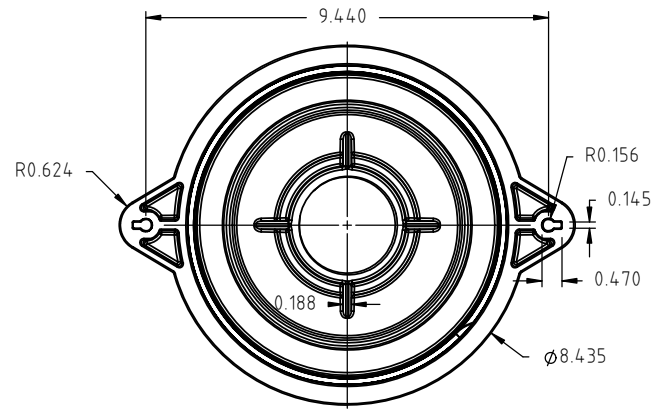
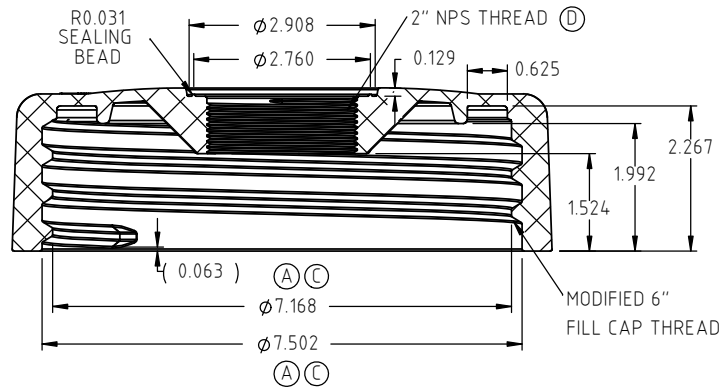
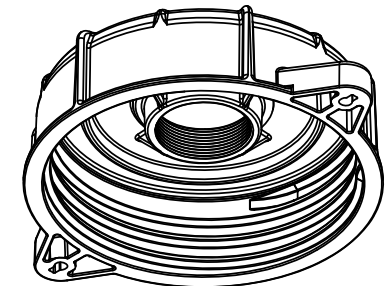
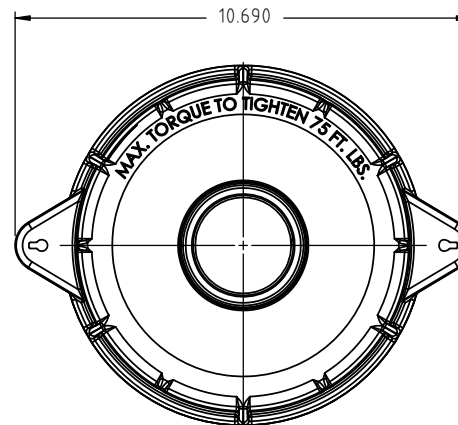
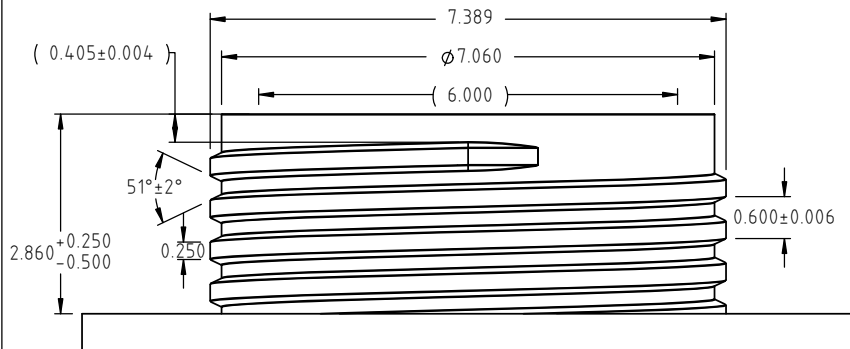

D	"NPS" CORRECTED FROM "NPT"	ADH 4/26/19	3760		
C	7.502 WAS 7.500, 7.168 WAS 7.145 .NECK DETAIL UPDATED.	ADH 4/11/19	3748	DRAWN / DATE ADH 2/12/18	MATERIAL 66609
B	TOLERANCE WAS XXX \pm .005" & XX \pm .010	ADH 3/5/19	3727	APPRD. / DATE REH 8/9/18	
A	7.500 WAS 7.440, 7.145 WAS 7.040 NECK DETAIL UPDATED.	ADH 12/14/18	3684		
REV	DESCRIPTION	BY / DATE	CCN		
ALL DIMENSIONS ARE IN DECIMAL INCHES TOLERANCES UNLESS OTHERWISE SPECIFIED		THIRD ANGLE PROJECTION ANSI 14.5M		SHOT WEIGHT: 475.54 GRAMS	NOTES:
NOTE		TOLERANCE: (B) $\pm .5\%$ ANGLE $\pm 1^\circ$		SHIPPING WEIGHT: 475.54 GRAMS	
				FINISH:	



Den Hartog
INDUSTRIES, INC.

Ace Roto-Mold Injection Molding Blow Molding Sowjoy

4010 HOSPERS DRIVE S. BOX 425, HOSPERS, IOWA 51238-0425

DESCRIPTION (D) 6" CAP-2" NPS THREAD	
SCALE N.S.	PART NO. 14836