

© DEN HARTOG INDUSTRIES, INC.

Copyright. All information furnished within this document, electronic file or design correspondence is the property of Den Hartog industries, Inc. and shall not be used, disclosed to others or copied without the expressed written consent of Den Hartog Industries, Inc.

KEY	PART NUMBER	DESCRIPTION	QTY.
1	14835	6" CAP - 2.5-5 BUTTRESS THREAD	1
2	14838	6" CAP GASKET-SANTOPRENE	1

14889

A

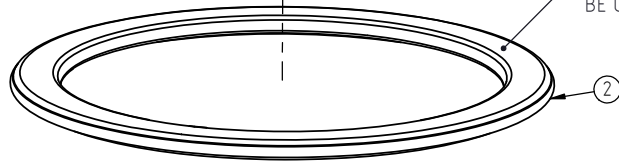
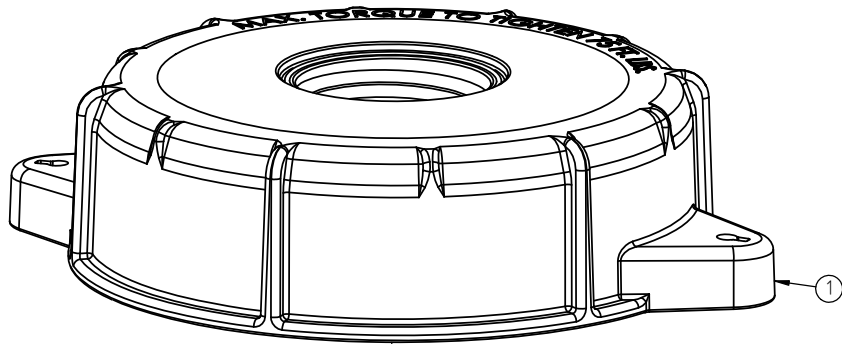

NOTE: GASKET FLATNESS AFTER INSTALLATION TO BE WITHIN .040"

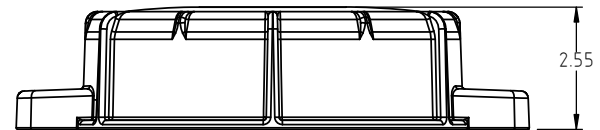
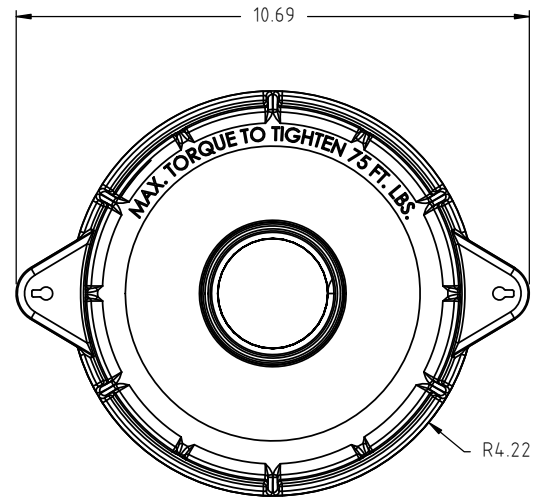

				DRAWN / DATE ADH 5/31/18	MATERIAL SEE COMPONENTS
A	TOLERANCE WAS XXX ± .005" & XX ± .010	ADH 3/5/19	3727	APPRD. / DATE REH 8/9/18	
REV	DESCRIPTION	BY / DATE	CCN		
ALL DIMENSIONS ARE IN DECIMAL INCHES TOLERANCES UNLESS OTHERWISE SPECIFIED		THIRD ANGLE PROJECTION ANSI 14.5M		SHOT WEIGHT: N.A.	NOTES:
NOTE	TOLERANCE: A ± 5% ANGLE ± 1°	SHIPPING WEIGHT: 576.70 GRAMS		FINISH:	



Den Hartog
INDUSTRIES, INC.

Ace Roto-Mold Injection Molding Blow Molding Sowjoy

4010 HOSPERS DRIVE S. BOX 425, HOSPERS, IOWA 51238-0425

DESCRIPTION 6" CAP - 2.5-5 BUTTRESS THREAD AND GASKET ASSEMBLY-SANTOPRENE	
SCALE N.S.	PART NO. 14889