

Copyright. All information furnished within this document, electronic file or design correspondence is the property of Den Hartog Industries, Inc. and shall not be used, disclosed to others or copied without the expressed written consent of Den Hartog Industries, Inc.

KEY	PART NUMBER	DESCRIPTION	QTY.
1	14750	RING	1
2	14752	LID	1
3	15081	ARM-BLACK	1
4	14756	LID FLOAT ASSEMBLY	1
5	14753	VENT BASE, VENTED	1
6	14755	PIN	1
7	14760	VENT LABEL	1
8	15067	GASKET, 16" TECOMECS LID	1 (A)
9	14764	O-RING, 4mm WIDE X 146mm ID	1
10	12880	GASKET, 16" TANK LID	1
11	15164	TIE STRAP, 8" NYLON BLACK	1 (B)

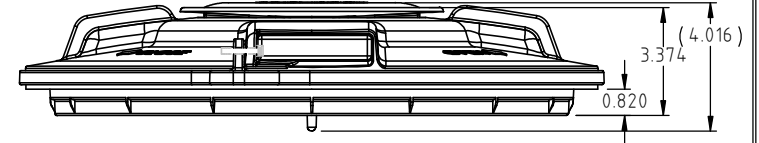

APPLY 90369 LUBRICANT TO 15067 AND 14764 O-RING & GASKET BEFORE ASSEMBLY.

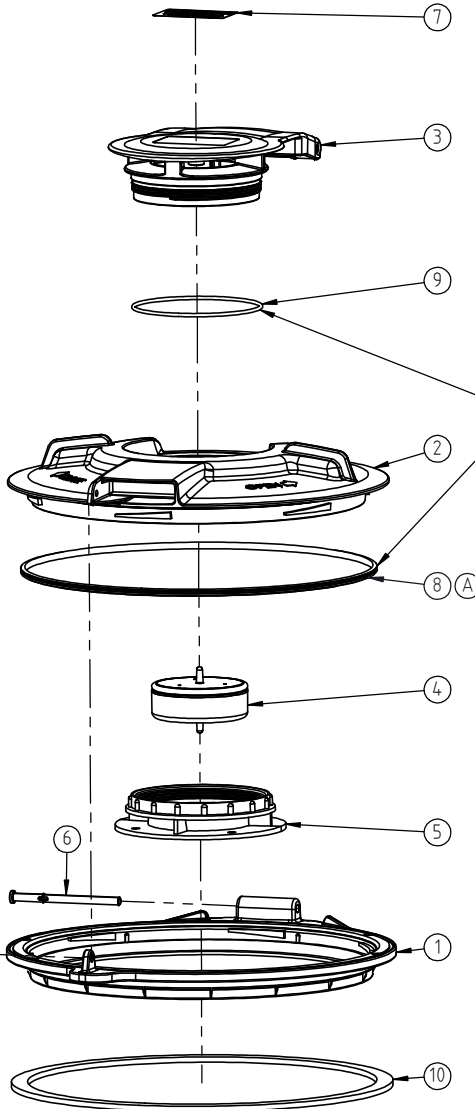
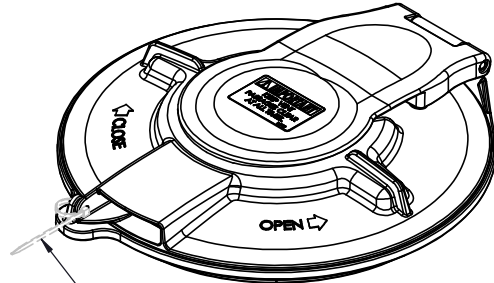
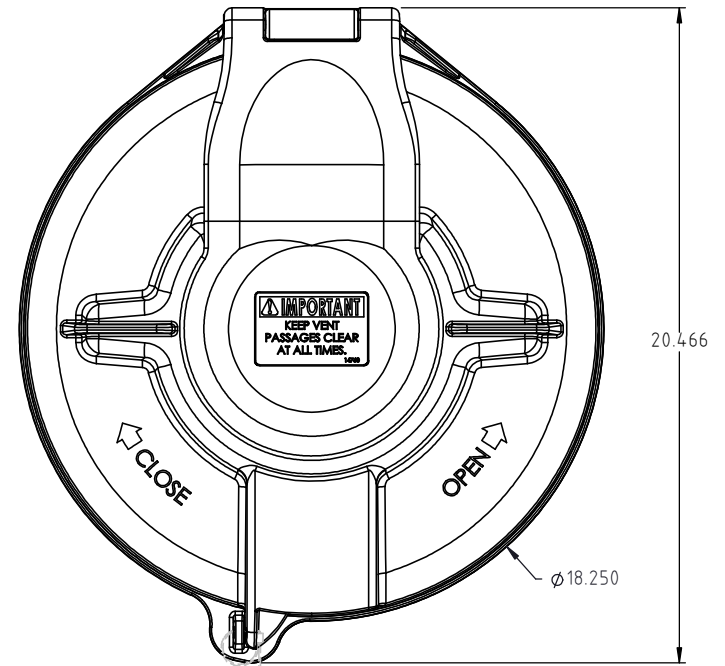

FASTEN 15164 TIE STRAP AFTER LID HAS BEEN INSTALLED TO SECURE LID FOR TRANSPORTATION.

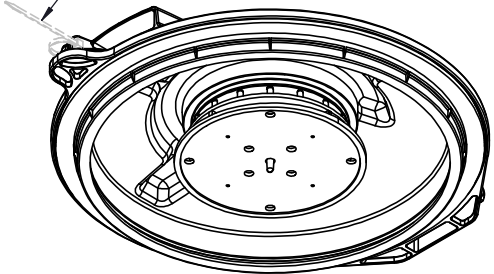

B	TIE STRAP/NOTE ADDED.	ADH 8/12/20	4008	DRAWN / DATE HLN 08/07/19	MATERIAL  SEE COMPONENTS
A	15067 WAS 14053	ADH 3/12/20	3931	APPRD. / DATE REH 09/05/19	
REV	DESCRIPTION	BY / DATE	CCN		
ALL DIMENSIONS ARE IN DECIMAL INCHES TOLERANCES UNLESS OTHERWISE SPECIFIED		THIRD ANGLE PROJECTION ANSI 14.5M		SHOT WEIGHT: N.A.	NOTES:
NOTE		TOLERANCE: .XXX ± .005" .XX ± .010 ANGLE ± 1°		SHIPPING WEIGHT: 5.5 LBS.	
		FINISH:			



**Den Hartog**  
INDUSTRIES, INC.

Acra Roto-Mold Injection Molding Blow Molding Sowjoy

4010 HOSPERS DRIVE S. BOX 425, HOSPERS, IOWA 51238-0425

DESCRIPTION	16" HINGED LID ASSEMBLY, VENTED	
SCALE	N.S.	PART NO. 15082