

© DEN HARTOG INDUSTRIES, INC.

Copyright. All information furnished within this document, electronic file or design correspondence is the property of Den Hartog Industries, Inc. and shall not be used, disclosed to others or copied without the expressed written consent of Den Hartog Industries, Inc.

KEY	PART NUMBER	DESCRIPTION	QTY.
1	19570	3" FITTING RING WELDMENT	1
2	19554	3" FITTING GASKET	2
3	19572	3" FITTING RING	1
5	12038	NUT, 5/8" NYLOK SS	6

19569

B

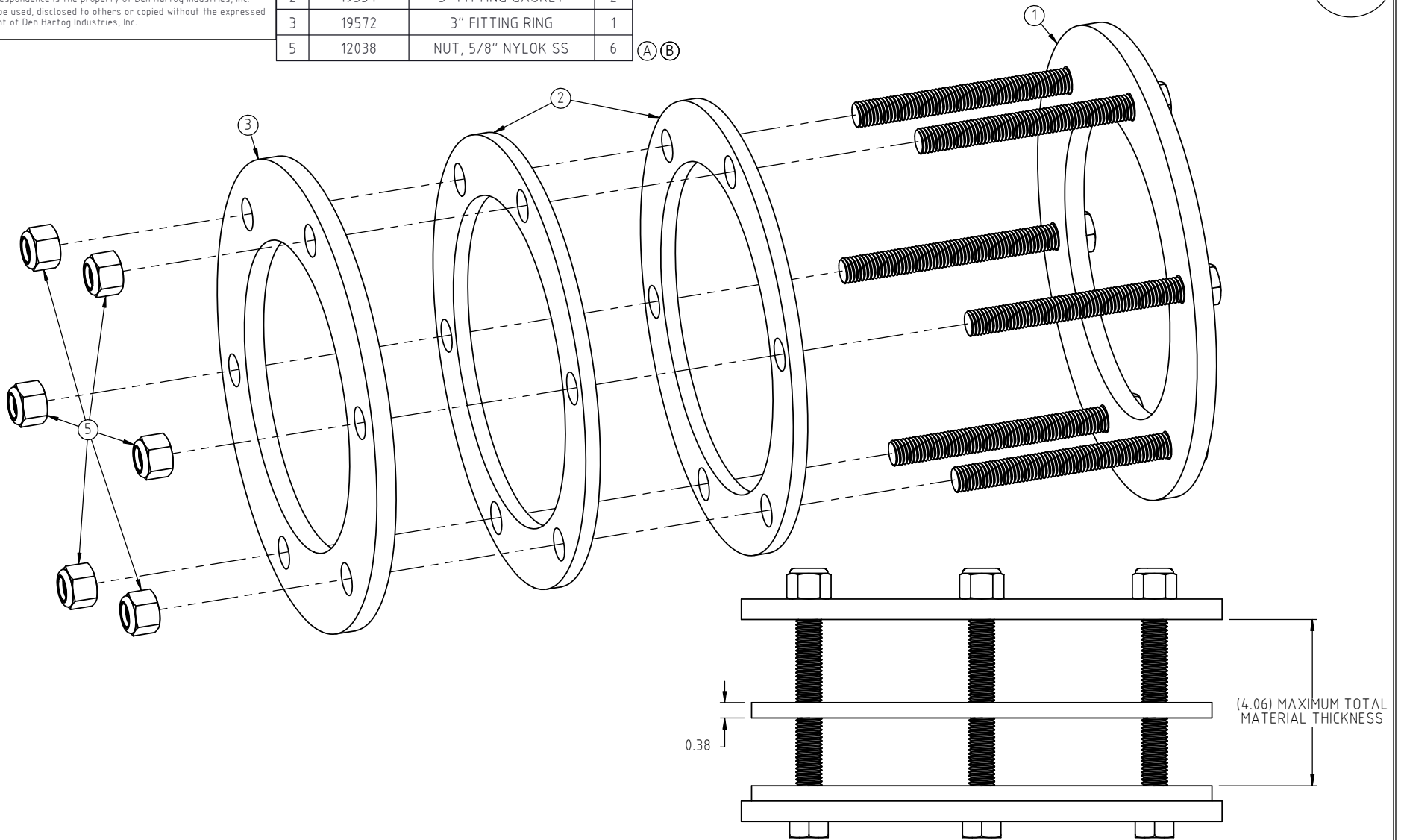

B	12038 WAS 19573	ADH 5/21/19	3779	DRAWN / DATE ADH 9/26/14	MATERIAL SEE COMPONENTS
A	19573 DESCRIPTION CORRECTED	ADH 5/2/16	3247	APPRD. / DATE REH 11/14/14	
REV	DESCRIPTION	BY / DATE	CCN		
ALL DIMENSIONS ARE IN DECIMAL INCHES TOLERANCES UNLESS OTHERWISE SPECIFIED		THIRD ANGLE PROJECTION ANSI 14.5M		SHOT WEIGHT:	NOTES: 1.) PATENT 9,162,816
POLYETHYLENE		METAL DECIMAL ± .125" FRACTION ± 1/4" ANGLE ± 1°		SHIPPING WEIGHT: XXXX	
±1% @ 68°F				FINISH: NONE	



**Den Hartog**  
INDUSTRIES, INC.

Ace Roto-Mold Injection Molding Blow Molding Sowjoy

4010 HOSPERS DRIVE S. BOX 425, HOSPERS, IOWA 51238-0425

DESCRIPTION	3" DUAL LINE™ TANK FITTING RING ASSEMBLY	
SCALE	N.S.	PART NO. 19569